

# Coolant Pumps General Catalog















**TERAL**



**TERAL: Maximizing Effectiveness**

50Hz/60Hz



Document for selection		Usage and Table of General Specification	General Concept Chart for Use in Selecting Products	Features	How to choose pumps	Precautions concerning storage handling, Things to confirm when placing an order	
		P.3	P.4	P.6	P.8	P.9	
Installation type	Flow rate	Low flow rate		Medium flow rate	High flow rate		
	Head						
Immersion type (Non-self-priming)	Low head	<b>VKP model</b>  P.12					
		<b>LFE model</b>  P.20					
	Medium head	<b>LHW model</b>  P.22					
		<b>VKD model</b>  P.24					
		<b>VKC model</b>  P.30		<b>LFO model</b> ※ Available for dirty liquid P.35 			
		<b>LBK model</b>  P.40		<b>LPW model</b> ※ Available for dirty liquid P.49 			
	High head	<b>LKW model</b>  P.61	<b>VKB model</b>  P.65				
		<b>LVS model / LVSS model</b>  P.75    P.92					
	Floor type (Self-priming)	Low head	<b>VKN model</b>  P.109				
		Medium head			<b>LPS model</b>  P.115		
Immersion type (For cleaning inside tanks)	Low head	<b>SKM model</b>  P.121		※ Available for dirty liquid These are the pumps to use after the primary process through mesh cage, chip conveyor, or magnet separator, etc.			

The frame for each unit type is colored by the material of the impeller

- Stainless steel (SUS304)
- Cast iron (FC, FCD)
- Others (Resin, CAC407)

### Usage

- Circulation and transfer of coolant for machine tools  
For internal environment of machine tools such as spindle, drill, end mill, etc., or transfer
- Circulation and transfer of cleaning liquid  
For washing work, jig, bed, inside of the machine, etc.  
For shower washing and splash gun
- For various filtration
- For pumping from the tank
- Other purposes

### Table of General Specification

Installation type	Priming method	Dirty liquid	Sealing structure	Model	Stage	Immersion type: Immersion depth <sup>※1</sup> Floor type: maximum suction lift	Material			Frequency (Hz)	Representative discharge rate <sup>※2</sup> (L/min)	Max. head <sup>※2</sup> (m)	Output <sup>※1</sup> (kW)	Allowable kinematic viscosity (mm <sup>2</sup> /s)	Poles (P)	CE marking	
							Impeller	Discharge casing	Intermediate casing guide vane								
Immersion type	Non-self-priming	—	Non-seal	VKP model	Single	130~350mm	Resin or CAC407	FC150	—	50	13 ~ 165	7	0.02 ~ 0.75	300	2	○	
		60	19 ~ 285	7	0.02 ~ 0.75	150	2										
		—	Non-seal	VKP-H model	Single	145~280mm	Resin or CAC407	FC150	—	50	10 ~ 20	13	0.06 ~ 0.4	37.5	2	○	
		60	10 ~ 20	18	0.06 ~ 0.4	2											
		—	Non-seal	LHW model	Multiple	200mm	Resin	FC200	Resin	50	20 ~ 80	50	0.75 ~ 1.1	1	2		
		60	20 ~ 90	73	0.75 ~ 1.1	2											
		—	Mechanical seal	VKC model	AH	Multiple	139~259mm	SUS304	SCS14A	SUS304	50	40	48	0.1 ~ 0.7	37.5or75 <sup>※1</sup>	2	○
		60	50		62	0.17 ~ 1.19	2										
		—	Mechanical seal	AQ	Multiple	137~249mm	SUS304	FC200	SUS304	50	85	26	0.18 ~ 0.72	2			
		60	100	36	0.3 ~ 1.2	2											
		—	Non-seal	LBK2 model	Multiple	153~297mm	SUS304	FC200	SUS304	50	25 ~ 42	66	0.35 ~ 1.8	75	2	○	
		60								30 ~ 50	88.9	0.55 ~ 2.2	2				
		—	LBK4 model	Multiple	153~342mm	SUS304	FC200	SUS304	50	85	32.9	0.35 ~ 1.8	2				
		60							100	47.6	0.55 ~ 2.2	2					
		—	Non-seal	LFE model	Single	300mm	FCD450	FC200	—	60	60 ~ 430		0.25 ~ 0.75	1	2		
		Available	Non-seal	LFO model	Single	350/500mm	FCD450	FC200	—	50	100 ~ 750	24	0.75 ~ 5.5	A:32 B:150	2		
		60	100 ~ 900	36	0.75 ~ 5.5	2											
		—	Non-seal	VKD model	Multiple	258~402mm	FC200	FC200	FC200	50	80 ~ 400	40	0.75 ~ 3.0	75	2	○	
		60	100 ~ 500	54	0.75 ~ 3.0	2											
		Available	Non-seal	LPW model	Multiple	255~330mm	FCD450	FC200	FC200	50	50 ~ 700	63	0.75 ~ 7.5	40C:32 40D:150 50A/65A:1	2		
60	60 ~ 750	64	0.75 ~ 7.5	2													
—	Non-seal	LKW model	Multiple	330 (Single)mm	Resin	FC200	Resin (+SUS304)	50	20 ~ 70	400	2.0 ~ 4.0×2	1	2				
60	20 ~ 70	400	2.0 ~ 4.0×2	2													
—	Non-seal	VKB model	H	Multiple	300~616mm	SUS304	FC200	SUS304	50	40	114	0.4~2.6	37.5or75 <sup>※1</sup> FH/FQ:1	2	○		
60	50								152	0.68~3.57	2						
—	Non-seal	Q	Multiple	291~711mm	SUS304	FC200	SUS304	50	85	78	0.54~3.96	2					
60	100							108	0.9~3.6	2							
—	Non-seal	LVS model	Multiple	196~979mm	SUS304	FC200	SUS304	50	10~500	230	0.75~18.5	1	2	○			
60	10~600	260	0.75~18.5	2													
—	Non-seal	LVSS model	Multiple	196~979mm	SUS304	<b>SCS13</b>	SUS304	50	10~500	230	0.75~18.5	1	2	○			
60	10~600	260	0.75~18.5	2													
Floor type	Self-priming	—	Mechanical seal	VKN model	A	Single	-0.7m	Resin or CAC407	FC150	—	50	13 ~ 230	7	0.04 ~ 0.75	200	2	○
					60	16 ~ 320	7	0.04 ~ 0.75	75	2							
		—	Mechanical seal	H	Single	-0.7m	Resin or CAC407	FC150	—	50	10 ~ 20	12	0.06 ~ 0.4	37.5	2	○	
										60	10 ~ 20	17	0.06 ~ 0.4		2		
		—	Non-seal	LPS model	Multiple	-0.7m	FCD450	FC200	FC200	50	50 ~ 650	62	0.75 ~ 7.5	40C:32 40D:150 50A/65A:1	2		
										60	50 ~ 700	64	0.75 ~ 7.5		2		
Immersion type	Non-self-priming	—	Non-seal	SKM model	Single	257mm	SUS304	FC150	—	50	50	6	0.25	1	2		
										60	50	9	0.25		2		

※1 : The value depends on the type. Please refer to the specification table of each unit type.

※2 : The value is a typical performance value. Please refer to selection chart and specification table for detailed performance of each model.

50Hz

Immersion type

Figures in the selection chart are colored by the material of impellers.

- Stainless steel (SUS304)
- Cast iron (FC, FCD)
- Others (Resin, CAC407)

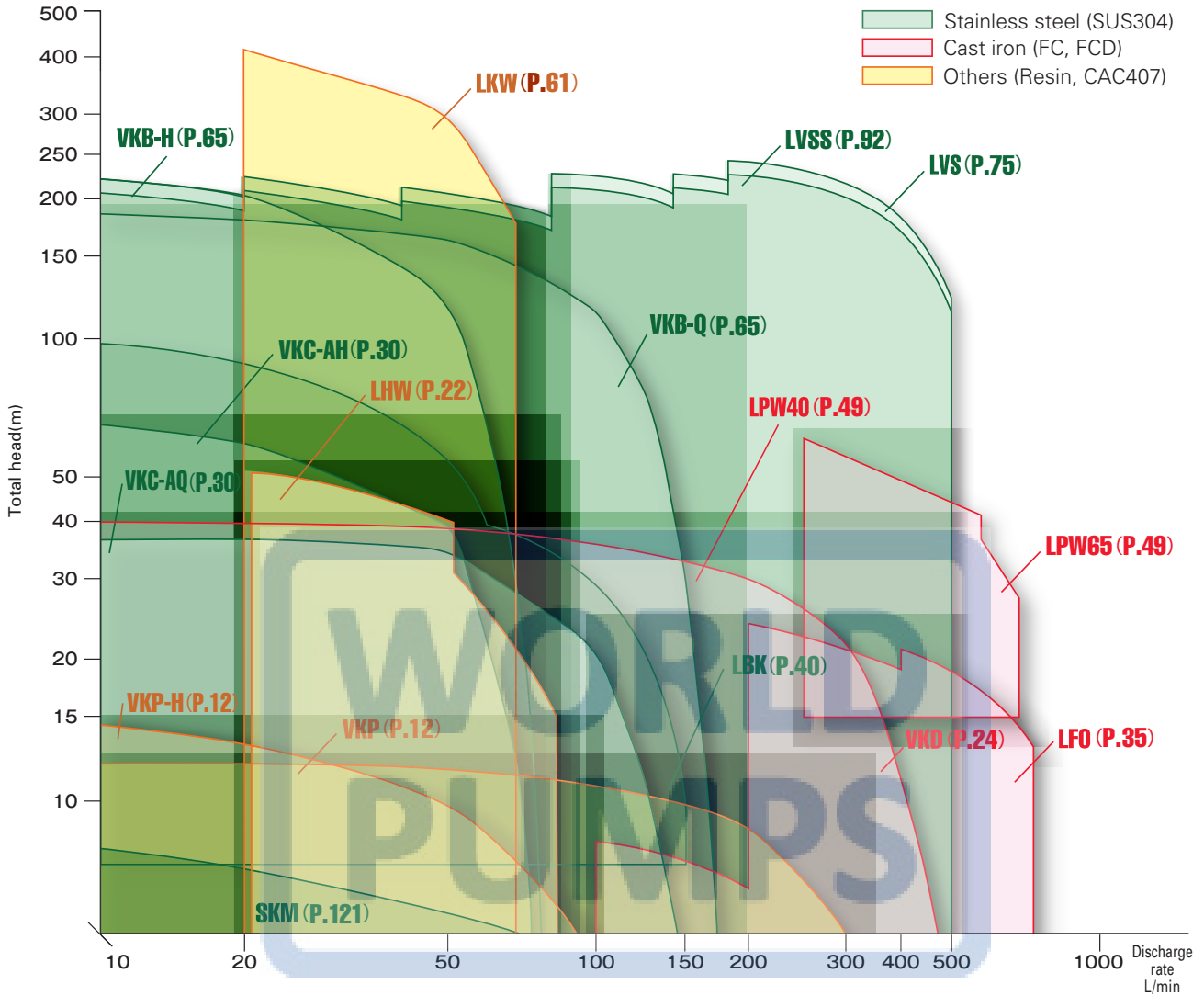

Floor type(Self-priming)

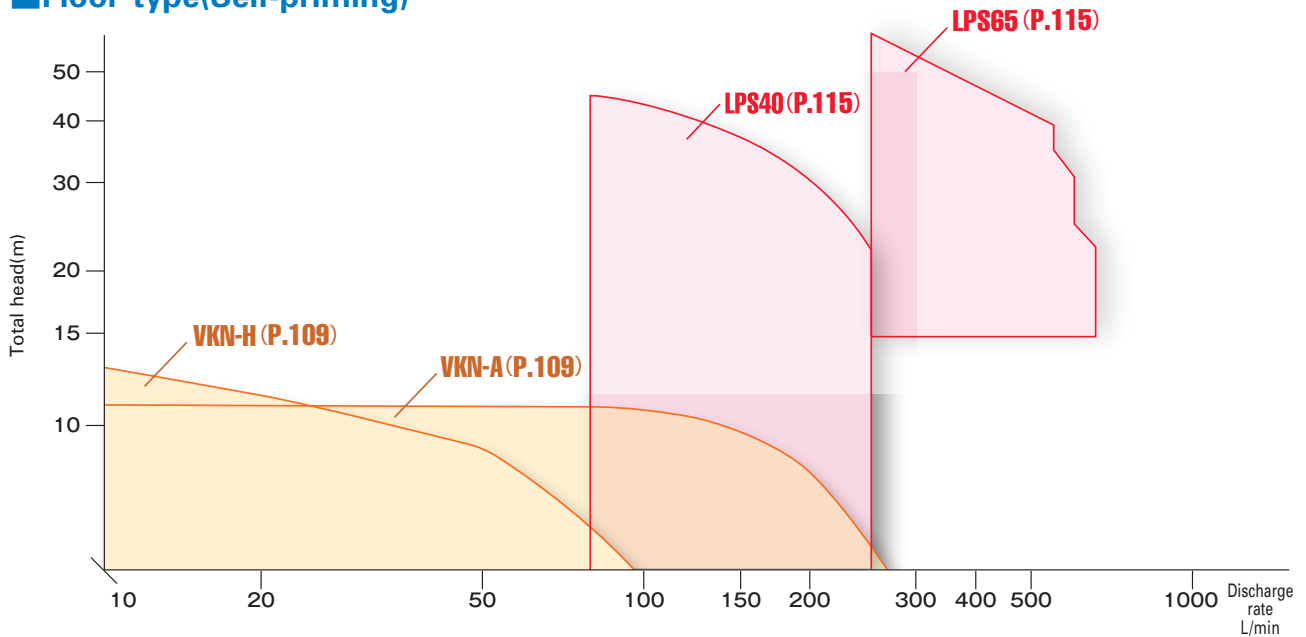

Please refer to the page of each unit type for the choices.

60Hz

### Immersion type

Figures in the selection chart are colored by the material of impellers.

- █ Stainless steel (SUS304)
- █ Cast iron (FC, FCD)
- █ Others (Resin, CAC407)

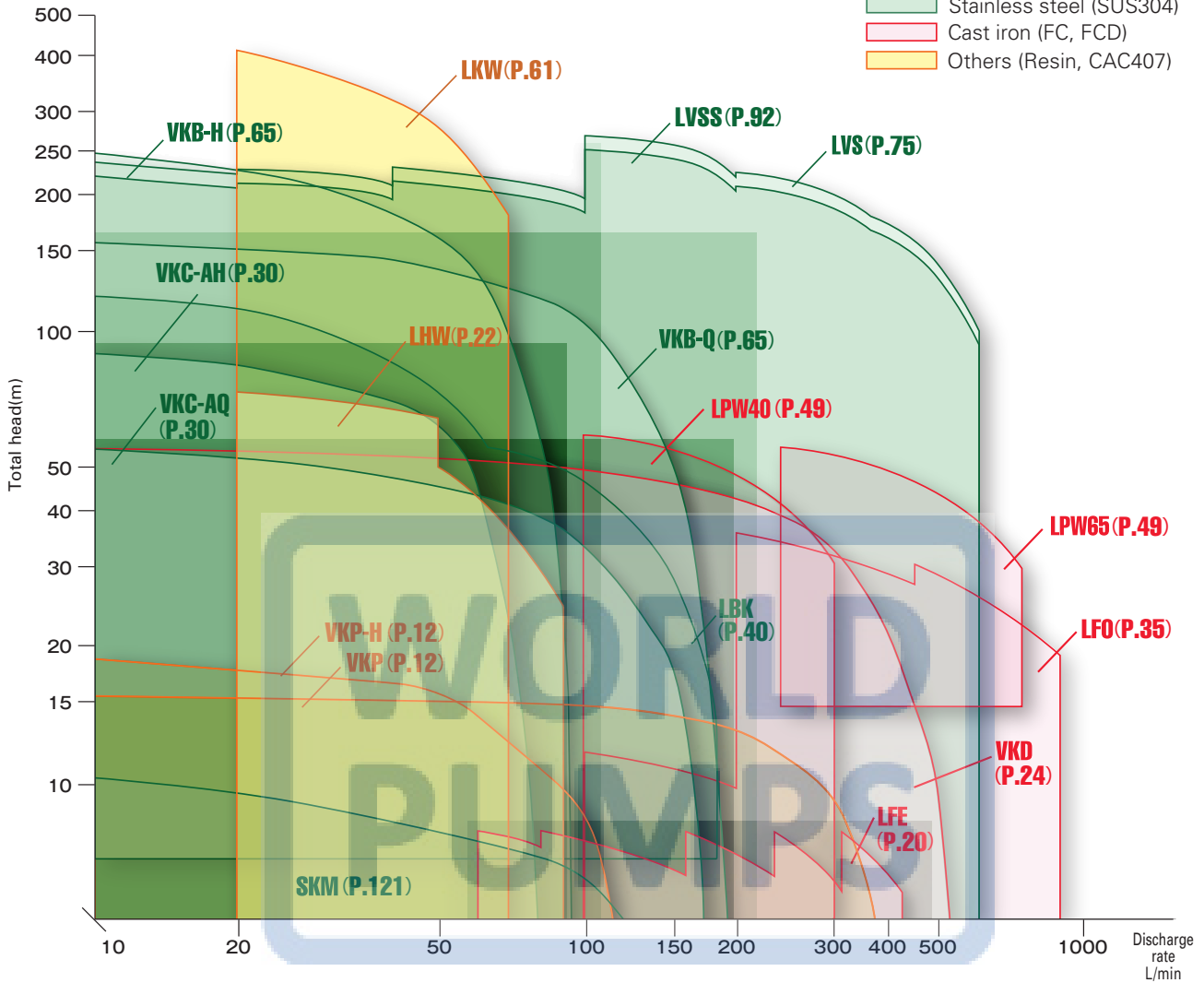

### Floor type(Self-priming)

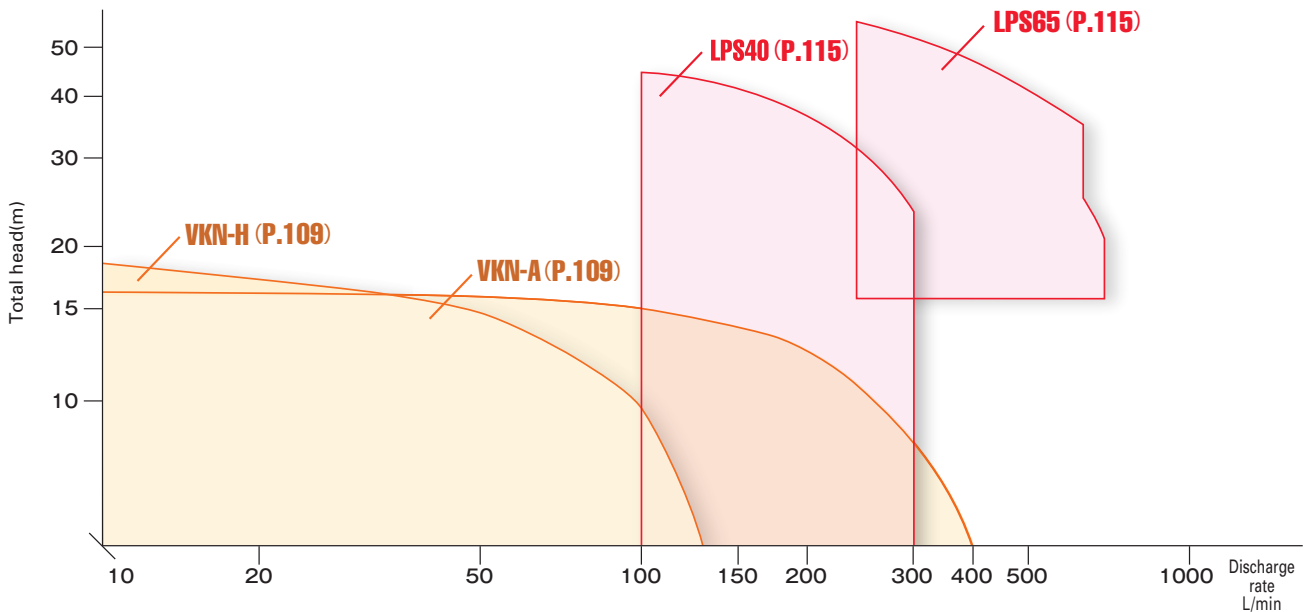

Please refer to the page of each unit type for the choices.

# Coolant pump by Teral

We have continued improvements reflecting our longtime experience and customers' opinions.

## Rich variation

### ● Installation method

**Immersion type**



VKP type LFO type LPW type etc...

**Floor type (Self-priming)**



VKN type LPS type etc...

**For cleaning inside tanks**



SKM type

### ● Shaft seal structure

**Mechanical seal type** (VKC type, VKN type) It is highly efficient because there is no leak in the shaft seal.

**Non-seal (mechanical seal-less) type**

- Resistant to sludge, they are usable for dirty liquid (some types).
- There are other features including following:

**TERAL' s original non-seal structure allows coolant to flow from a narrow clearance without using a seal between the pump section and the motor section.**

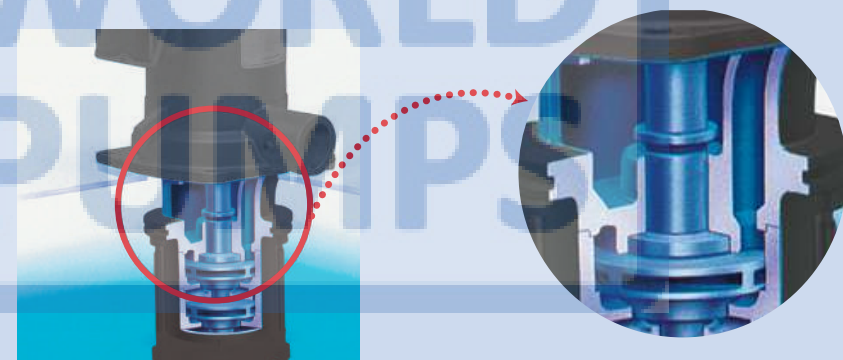

**Many advantages that only non-seal pumps can provide**

- 1 No coolant leakage or other problems.**  
Helps cut down running costs.
- 2 No need for a safety valve, escape piping, or a three-way valve.**  
Helps cut down initial costs.
- 3 Prevents air accumulation.**  
Reduces initial trouble.
- 4 Capable of serial running (LKW-D model)**  
A series of volute pumps can generate up to 3.92MPa
- 5 Not easily affected by small quantity of liquid or shut-off operation.**  
Build the pump system you want.
- 6 Not easily affected by chips**  
Can be used for dirty coolants. (some types)

**※What is non-seal structure?**  
This structure inwardly releases coolant by depressurizing through a narrow clearance without the use of a mechanical seal.

### ● Others

<b>[Material of the impeller and casing]</b> Stainless steel, cast iron, resin, etc.	<b>[Performance]</b> Low - high flow rate, low - high head	<b>[Length of the immersion part]</b> There are alternatives (some types)
---	---	--

You can make a choice according to the various uses.

## High Durability, Abrasion Resistant

### High Efficiency is realized with 3-dimensional fluid analysis & structural analysis (LVS-e type)

- Energy conserving by enhancing the efficiency of pumps
- Life cycle cost saving by non-seal structure



Example of fluid analysis in impellers

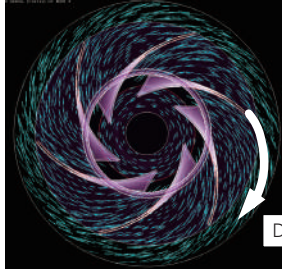

The flow of the fluid in the impeller is simulated with computers to optimize the shape of the impellers. Each line in the figure shows the flow of the fluid.

Direction of the flow

### High durability is demonstrated with our reliability test (VKB type)

- Reduction of characteristic value is within 10%
- No leak, no abnormal vibration or sound.
- No abnormal abrasion of parts

※ Validated with the operation test (accelerated life test) of 2 years (about 17,500 hours, switching on/off 4.2 million times)

A tank containing sludge (slurry content is about 10wt%)



Scene of the testing

※ It is the result of the internal test. Durable life of pumps and their parts differ by liquid and operation circumstances.

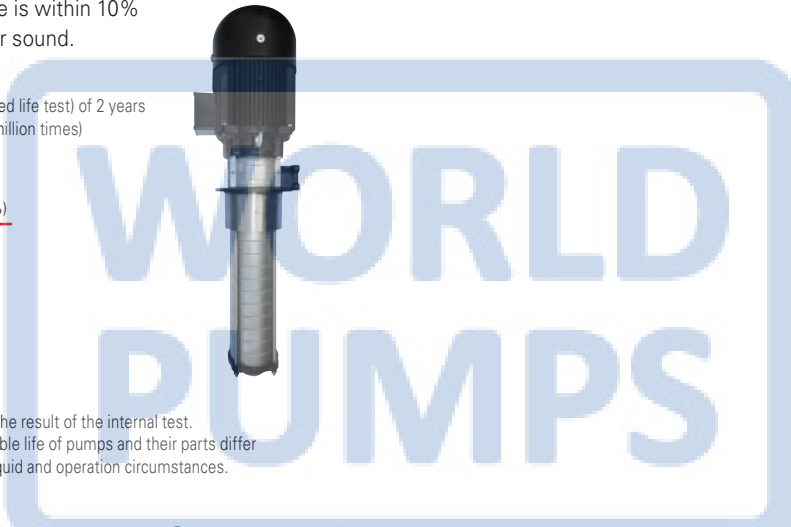

## They comply with Top Runner Standard (IE3) and other overseas standards (depending on type)

### Top Runner Energy Efficiency Standard (equivalent to IE3) Compliant

Top Runner efficiency (equivalent to IE3) motor saves energy (some types are excluded). Pumps with Top Runner efficiency (equivalent to IE3) motor have "-e" at the end of their typed ID. Additionally, they have "Triple e" seals on them (see below)

### Complying with EU Directive (CE Marking), EU RoHS Directive (RoHS 6 restricted substances)

Enabled model: VKP, LBK, VKD, VKB, LVS, LVSS, VKN, VKC



### Complying with the UL Standard of USA

(Those with power of 0.75 kW or more comply with NEMA premium)

Enabled model: VKP-7W, VKD-7W, LPW-7W, VKN-7W

With energy conservation needs rising on a global scale, Teral is working with the corporate concept of "Triple e."



## Mind of "Triple e":

High **e**fficiency products realize saving **e**nergy and preserving the Earth **e**nvironment

This mindset is directly connected to the feelings expressed in the name "TERAL," our slogan and Corporate Vision: "To create the future with water and air."

Pumps are very influenced by the state of their piping (piping length, kinds of coupling joints, their numbers, etc.). Therefore please make the piping as short as possible, and make bends, such as elbows, joints, and valves as few as possible. When you select pumps, specifications including usage, processed liquid, flow rate, and total lifespan need to be fully considered. Calculation of the total head is shown below. Please use it as a reference.

● How to calculate Total Head

Figure 1

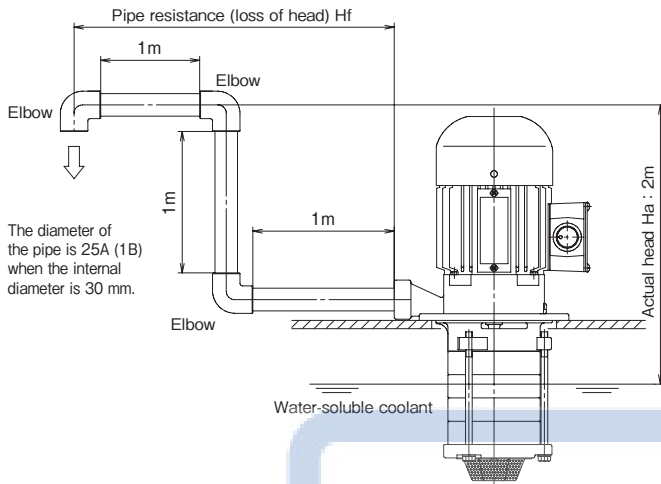

Necessary total head is calculated assuming the flow rate of 50 L/min in the piping state shown in Figure 1.

Total head is computed as follows:  
 Total Head  $H_t[m] = \text{Actual Head } H_a[m] + \text{Loss of Head } H_f[m]$

In the case shown in Figure 1:  
**Actual head  $H_a$ : 2 m, Loss of Head  $H_f$ : 0.79 m** <sup>※1</sup>  
 From the above formula,  
**Total head is 2 m + 0.79 m = 2.79 m.**

Therefore, pumps that satisfy total head 2.79 m or above should be selected. (Figure 2)

[Note]  
 The above calculation is for a case of water-soluble coolant (kinematic viscosity 1 mm<sup>2</sup>/s), There are some cases that the loss of head is very different, depending on type and viscosity of liquid used, piping conditions, etc.

Figure 2 Pump characteristic curve

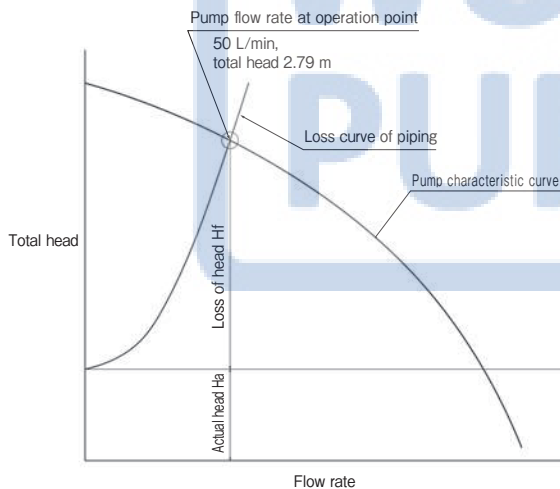

※1 How to compute loss of head

Loss of head is calculated as follows:  
 Loss of head  $H_f[m] = f \times (L/d) \times V^2/2g [m]$   
 L: equivalent length of straight pipes [m] V: flow velocity [m/s]  
 d: internal diameter of the pipe [m] g: gravitational acceleration 9.8 [m/s<sup>2</sup>]  
 f: coefficient of loss

In the case shown in Figure 1:  
**Equivalent length of straight pipes, L: 11.1 m** <sup>※2</sup>  
**Flow velocity, V: 1.18 m/s**  
**Internal diameter of the pipe, d: 0.03 m**  
 From the above formula,  
**Loss of head  $H_f = 0.03 \times (11.1/0.03) \times 1.18^2 / (2 \times 9.8) = 0.79 m$**

[Note]  
 Coefficient of loss is the value assuming that the aqueous solution is 0.03. Please note that the coefficient differs greatly for oily liquids.

Table 1 Table of approximate equivalent length of straight pipes for elbows, etc. [m]

Nominal diameter	Inlet part	Outlet part	90-degree elbow	Ball valve
8A (1/4B)	0.3	0.6	0.7	6.4
10A (3/8B)	0.4	0.8	0.9	6.7
15A (1/2B)	0.6	1.2	1.1	6.7
20A (3/4B)	0.8	1.6	1.3	7.3
25A (1B)	1.1	2.2	1.6	8.8
40A (1 1/2B)	1.9	3.2	2.3	12.8

※2 How to calculate equivalent length of straight pipes

"Equivalent length of straight pipes" is the measurement of loss generated by elbows, valves, etc., expressed by the length of a straight pipe with the same diameter causing the same amount of pressure loss.

In the case shown in Figure 1:  
**Straight part: 1 m + 1 m + 1 m**  
**Elbow: 1.6 m × 3 = 4.8 m**  
**Inlet: 1.1 m, outlet: 2.2 m**  
**Equivalent length of straight pipes, L = 3 m + 4.8 m + 1.1 m + 2.2 m = 11.1 m**

[Note]  
 Please refer to Table 1 for gross equivalent length of straight pipes of elbow, etc.

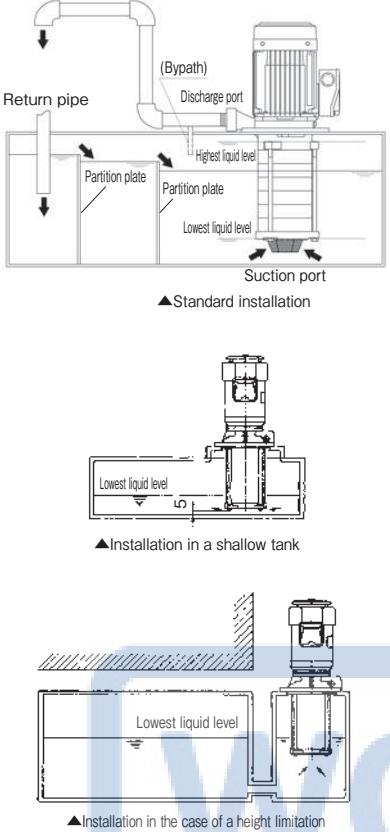
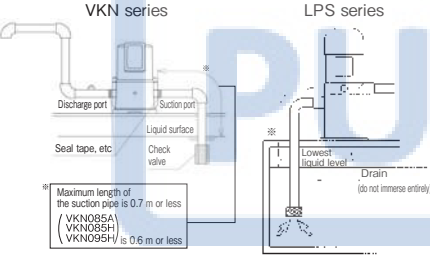
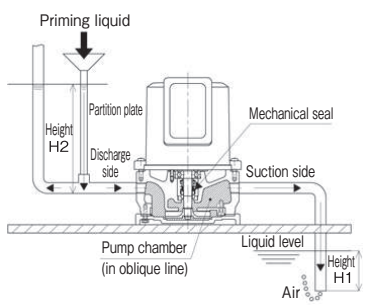
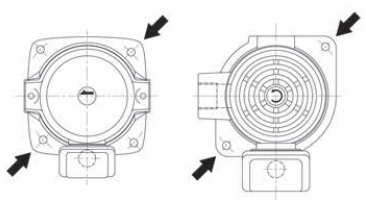

Item	Model	Content
Installation	Immersion type	 <ul style="list-style-type: none"> <li>● Make the piping as short as possible, and make the corners like elbow, joints, and valves, etc., as few as possible. Additionally, please use pipes with standard diameter. Please note that sometimes discharge becomes low if the pipe is thin or there are many corners.</li> <li>● Support the piping sufficiently so that the pump does not take the load of pipes.</li> <li>● Do not screw pipes into pumps forcefully. Joint may be damaged.</li> <li>● Roll on the screw thread of pipes with seal tape, etc., so that liquid or gas does not leak. Additionally, roll the seal tape securely so that the tape does not block the pipe.</li> <li>● Tank (oil tank) should be as large as possible.                     <ul style="list-style-type: none"> <li>※Recommended capacity is 3 times as much as the quantity of discharge per minute. If the capacity is too small, there can be some faults, such as a rise in liquid temperature, early clogging of strainer with chip powder, etc., and the reduction of discharge caused by air bubbles.</li> <li>※When the liquid is poured into pumps, pour calmly so that they do not catch air bubbles.</li> </ul> </li> <li>● Be careful that chip powder or dust does not enter inside the pumps.                     <ul style="list-style-type: none"> <li>※Filter the liquid with mesh cages, chip conveyors, magnet separators, etc., before pumping the liquid. The number of necessary processes differs by type.</li> </ul> </li> <li>● Take appropriate measures, such as setting up a bypass after the discharge outlet of the pump, if there can be a water hammer.</li> <li>● If the liquid level is too low, discharge will be reduced or sometimes it becomes unable to lift liquid because of air inside. The liquid level shall be higher than the lowest liquid level shown in the assembly drawing. Note that the lowest liquid level differs by kinematic viscosity or the state of the surface. Please give a sufficient margin of height for safety. Additionally, if the liquid level is too high, liquid might enter inside the motor from the drain hole, consequently causing the motor to be out of order. Make the liquid level lower than the highest liquid level shown in the assembly drawing.</li> </ul>
	Self-priming type	 <ul style="list-style-type: none"> <li>● Install them close to the tank (oil tank) so that the suction pipe may be as short as possible. Maximum length of the suction pipe shall be 0.7 m (0.6 m for VKN085A, VKN085H, VKN095H) or less. If a suction pipe must be longer for some reason, install a check valve in the pipe on the suction side. Additionally, seal on the screw thread of the pipe with seal tape, etc., to avoid leak of liquid or air. Especially if there is an air leak, the flow rate will be reduced or it will run short of lift liquid.</li> </ul>
Priming liquid	Self-priming type	 <ul style="list-style-type: none"> <li>● In the first operation after the installation, or long after the last operation, the pump chamber (oblique line in the figure below) might be filled with air. Because of this, venting the air with priming liquid is necessary. Air in the pump chamber can cause the pump to suck insufficiently/have pump characteristics insufficiently exerted (short of flow rate or pressure). Additionally, if the pump is operated for long time in a state of insufficient capacity, it might damage the mechanical seal, etc.</li> </ul> <p>[How to prime]</p> <p>VKN series</p> <ul style="list-style-type: none"> <li>● Priming liquid should be poured until the air in the pump chamber is entirely exhausted (until air stops bubbling from the tip of the suction pipe) from the discharge. If the height from the outlet to the inlet of the priming H2 is lower than the length of the suction pipe below the surface H1, priming may not sufficiently fill the pump. In this case, install an air vent in the suction pipe or make the inlet for the priming sufficiently high.</li> </ul> <p>LPS-e series</p> <ul style="list-style-type: none"> <li>● Pour the priming liquid in the priming inlet in the pump discharge until water comes out from the suction pipe.</li> </ul>
Installation	VKN VKP	 <ul style="list-style-type: none"> <li>● The VKN/VKP series have four mounting holes (excluding some types), but they are for enlarging the range of usage. Two diagonal holes are enough for actual mounting. (Two holes comply with the dimensions of the JEM standard, the other two holes are proprietary.)</li> </ul> <p>Mounting hole for VKN/VKP series Arrows point at the dimension in JEM standard.</p>

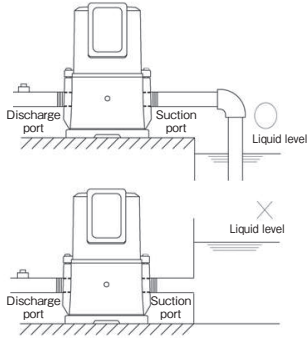
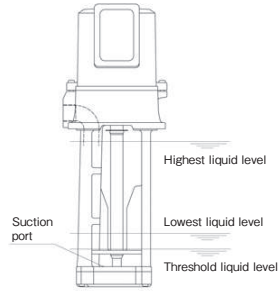
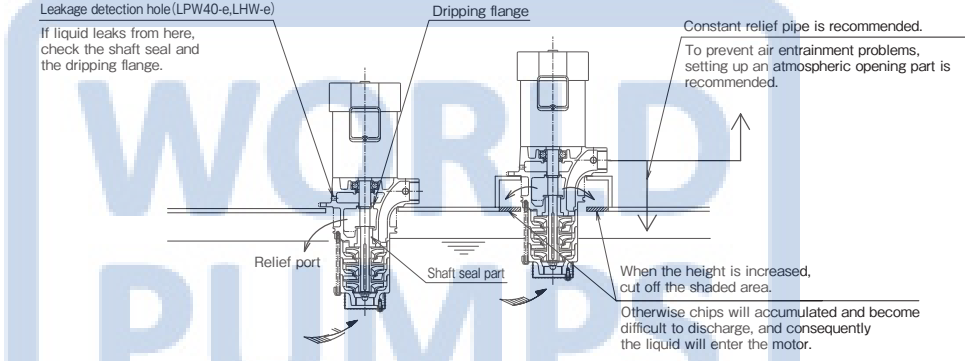
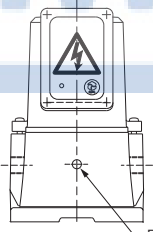
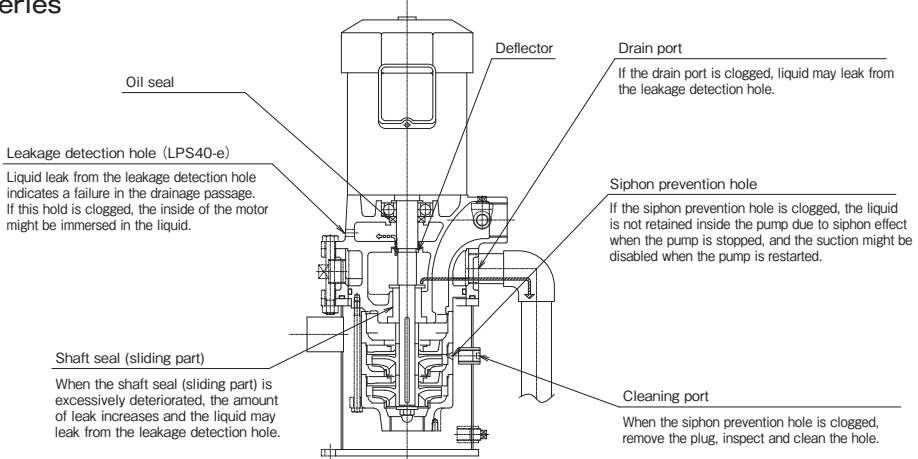
Item	Model	Content
Level of the liquid surface	VKN	 <p>● Make the liquid level of VKN series lower than the suction port of the pump. If the surface is higher than the suction inlet, liquid can leak from mechanical seal.</p>
	VKP	 <p>● Figures of upper suction type VKP series machines are shown at "lowest liquid level," "highest liquid level," and "threshold liquid level" in the outline drawing.</p> <p>"Lowest liquid level" It shows the range where the amount of discharge is about the same as the rated value, and there is no air biting.</p> <p>"Threshold liquid level" It shows the range where the amount of discharge becomes about half of the rated value and there is air biting.</p> <p>"Highest liquid level" Make it a distance from the pump flange surface by at least 20 mm.</p>
Prevention of problems for immersion type	 <p>If liquid leaks from here, check the shaft seal and the dripping flange.</p> <p>Constant relief pipe is recommended. To prevent air entrainment problems, setting up an atmospheric opening part is recommended.</p> <p>When the height is increased, cut off the shaded area. Otherwise chips will accumulated and become difficult to discharge, and consequently the liquid will enter the motor.</p>	
Prevention of problems in the suction type	VKN	 <p>Drain A leak from the drain is caused by problems with the mechanical seal</p>
	LPS	<p><b>LPS40 series</b></p>  <p>Oil seal</p> <p>Leakage detection hole (LPS40-e) Liquid leak from the leakage detection hole indicates a failure in the drainage passage. If this hold is clogged, the inside of the motor might be immersed in the liquid.</p> <p>Shaft seal (sliding part) When the shaft seal (sliding part) is excessively deteriorated, the amount of leak increases and the liquid may leak from the leakage detection hole.</p> <p>Deflector</p> <p>Drain port If the drain port is clogged, liquid may leak from the leakage detection hole.</p> <p>Siphon prevention hole If the siphon prevention hole is clogged, the liquid is not retained inside the pump due to siphon effect when the pump is stopped, and the suction might be disabled when the pump is restarted.</p> <p>Cleaning port When the siphon prevention hole is clogged, remove the plug, inspect and clean the hole.</p> <p>Note) Although the structure of LPS65-e is different from the above figure, notes about shaft seal (sliding portion), drain port, siphon prevention hole, and cleaning connection are applicable.</p>

Item	Content
<b>General</b>	<ul style="list-style-type: none"> <li>● Before using (installing, carrying, maintaining, etc.) the product, be sure to read the manual thoroughly. Be sure to use the machine after completely understanding the information on machines, safety, and cautions. Appropriate handling in each step from beginning to actual operation, as well as maintenance after the initial operation, is necessary to make the most out of the coolant pump, preventing accidents, and continuing good operation for long time.</li> <li>● Do not handle the machine when it is operating. Be sure to turn off the power before handing it.</li> <li>● In the case of a power outage, be sure to turn off the power switch.</li> <li>● If there is any problem, please stop operations and turn off the power switch.</li> <li>● Bury the earth terminal securely.</li> <li>● The piping and cable lining shall comply with electronic facility standards and internal line standards.</li> <li>● A protection device is not included in the package. It is required by law to install an overcurrent protective device. It is highly recommended to install other protection devices (earth leakage circuit breaker, etc.).</li> <li>● Take sufficient measures for dust proofing and dew proofing in order to prevent cut powder or coolant entering from lining hole into terminal box. Additionally, do not remove grommets from unused terminal holes.</li> <li>● Note that motor might be burned or thermal relay might trip if the voltage is volatile.</li> <li>● Do not use the products in an explosive atmosphere.</li> <li>● Never place any combustibles near the product.</li> <li>● We cannot produce machinery with increased safety or explosion proof.</li> <li>● Volatile liquids, such as kerosene or gasoline, cannot be used.</li> <li>● While operating, never touch or get close to rotating parts (external fan, impellers, etc.).</li> <li>● Do not put any material or fingers into the aperture of the product (fan cover, discharge opening, suction opening, drain hole, etc.).</li> <li>● Never climb the machinery.</li> <li>● Products become considerably hot while operating. Do not touch with your hand or any part of the body.</li> <li>● Do not restrict ventilation around the product.</li> <li>● Put it in a convenient location for maintenance operation (avoid narrow spaces).</li> <li>● Place it on a flat surface and anchor it so that it will not shake.</li> <li>● Select a rigid surface to install the product on so that vibrations will not be amplified in operation.</li> <li>● When it is run with inverters, the frequency shall not exceed 60 Hz. Avoid a frequency with which resonance occurs. Otherwise resonance may occur depending on installation conditions.</li> <li>● If the kinematic viscosity of the liquid is too high, the life of the motors might be shortened, or burn out. Be sure to use the liquid within the threshold kinematic viscosity [mm<sup>2</sup>/s] shown in the specifications.</li> <li>● They are designed as pumps for liquid containing fine powder or fine chips. But for the pumps using the mechanical seal (VKC/VKN), the life of the mechanical seal might be shortened if hard sludge, such as polishing powder, abrasive grain, or diamond powder, are contained in the liquid, the life of the mechanical seal might be shortened. Then install filters (magnetic filter or paper filter, etc.). Additionally, please note that special liquids, such as printing liquid or acid liquid cannot be used. Please inquire about other special liquids (e.g. ceramics).</li> <li>● Check the direction of rotation before connecting the machine.</li> <li>● For pumps with air fled valves, half open the valve and check if liquid is discharged when starting the operation. After it is confirmed, close the air fled valve securely.</li> <li>● Because it is a centrifugal pump, flow rate can be adjusted by adjusting the valve on the discharge side. Additionally, the motor will not be overloaded even if the valve is closed. Since the temperature of the liquid becomes high if it is operated with the valve closed, keep some flow rate, or stop the pump if it is not in use.</li> <li>● Repair, dismantling, or modification shall be done by experts.</li> <li>● If the product is modified by customers, it is not our responsibility. Then we cannot assume any responsibility.</li> <li>● If it is disposed of, treat it as an industrial waste.</li> <li>● Other than the products listed in the catalog, products for different voltages, etc. are also produced. Please inquire about them.</li> </ul> <div style="border: 1px solid black; padding: 5px; margin-top: 10px;"> <p>Because a product with motors of Top Runner Efficiency (corresponding to IE3) tends to consume more current than the ones with standard motors (IE1), it requires installation of earth leakage circuit breaker and overload protecting device when the pump is changed from the ones with standard motor.</p> </div>

### Things to discuss before placing an order

Specification must be discussed thoroughly to produce a reliable product which perfectly satisfies your requirements. Things to confirm when submitting a quote and placing an order are as follows:

- (1) **Usage** : If the machine is used for special purposes
- (2) **Liquid** : Type, kinematic viscosity, temperature, acidity, inclusion of sediments
- (3) **Pump specification** : Total head, amount of discharge, suction head (self-priming height)
- (4) **Motor specification** : Power, voltage, frequency, number of phases
- (5) **Use circumstances** : Ventilation, circumstance temperature, humidity
- (6) **Terminal** : Terminal marking, number of terminals, structure of the terminal box, etc.
- (7) **Piping** : Piping diagram
- (8) **Installation method** : Self-priming / Immersion type
- (9) **Type** : LBK4-60/1-e, etc.
- (10) **Standards for compliance**
- (11) **Others** : Specification on noise, vibration, or letters on the plate, etc.

**Features**

- ① Non-seal (mechanical-seal-less) structure is adopted.
- ② There are 3 types to choose for the immersion depth.
- ③ EU RoHs Directive (RoHS 6 restricted substances) compliant.
- ④ EU Directive for CE marking compliant.
- ⑤ We have the lineup of products corresponding to each efficiency standard:  
 VKP type : with a standard efficiency (IE1) motor  
 VKP-e type : with a Top Runner efficiency (Equivalent to IE3) motor (VKP115A)  
 VKP-7W type : with a UL-approved motor (750W is NEMA premium efficiency)
- ⑥ It can be upgraded to environmentally-tolerant (mist, etc.)
- ⑦ With the lineup of VKP-A type (flow rate type) and VKP-H type (pressure type), the range of head and flow rate can be expanded. The VKP-H model offers approximately 30% more pressure than the VKP-A type.



Please note that the paint color, etc. of the actual unit may partially differ from the photo.

**Description of types**

**VKP 08 5 A F**

- ① ② ③ ④ ⑤ ⑥

- ① Model
- ② Output 03:20W, 04: 40W, 05:60W, 06:100W, 07: 180W, 08: 250W, 09: 400W, 11: 750W
- ③ Series No.
- ④ Phase, Features (L: 3-phase(cabtyre cable used), A, J<sup>NOTE</sup>: 3-phase, flow rate type, H: 3-phase, pressure type)  
 Note) VKP□□□□J and VKP115A(-□) are bottom suction type.
- ⑤ Immersion depth F : 180mm  
 H : 250mm  
 K : 350mm
- ⑥ Motor efficiency/voltage None : Standard efficiency (equivalent to IE1) / Standard voltage  
 -e : Top Runner efficiency (equivalent to IE3) / Standard voltage  
 -4Z : Standard efficiency (equivalent to IE1) / Special voltage  
 -4Z-e : Top Runner efficiency (equivalent to IE3) / Special voltage  
 -7W : UL approved motor (750W is NEMA Premium efficiency)

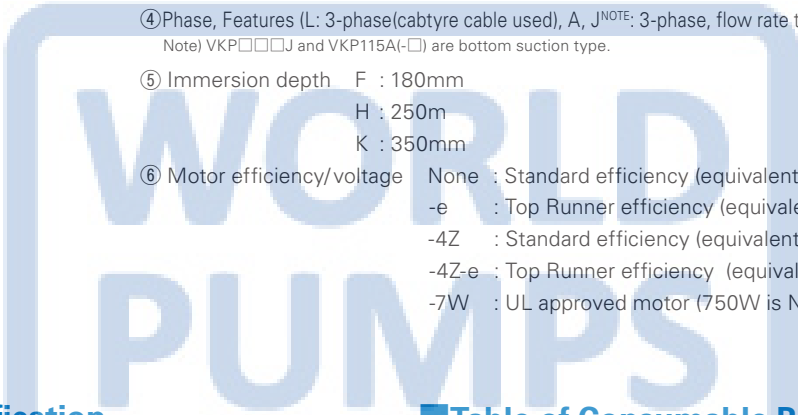

**Standard Specification**

Used liquid	Property of liquid	Grinding liquid, cutting liquid, etc <sup>※1</sup> .
	Temperature	40°C or below (no frozen liquid)
	Allowable kinematic viscosity	VKP-A 50Hz:300mm <sup>2</sup> /s 60Hz:150mm <sup>2</sup> /s VKP-H 50/60Hz:37.5mm <sup>2</sup> /s
Installation location		Indoor Ambient temperature: -20 to 40 °C, RH 85% or below (no condensation), Height above sea level : 1000m or less, Place not exposed to direct sunlight, Place in an area free of corrosive or explosive gas or vapor.
Material	Pump legs Casing	FC150
	Impeller	CAC407 or special resins Refer to the list of impeller materials
	Main shaft	S45C
Sealing structure		Non-seal (mechanical seal-less)
Motor	Power source	3-phase 50/60/60 Hz, 200/200/220 V <sup>※2</sup>
	Type	Totally enclosed fan-cooled indoor type
	Protection method	Refer to specification table
	Thermal class	Refer to specification table
	Rating	Continuous
	Number of poles	2P
Standard		IEC60034-1 CE Marking <sup>※3</sup>
Paint color		Munsell N1

※1 Take note that special liquid such as water, printing liquid or acid liquid cannot be used.  
 ※2 -4Z type: 50/50/50/60/60Hz 380/400/415/400/440V, -7W type: 60Hz 208/230/460V  
 ※3 Excluding -7W type and the types whose ID ends with "L."

**Table of Consumable Parts**

Type	Bearing	
	Load side	Unload side
VKP035L	6200ZZ	6200ZZ
VKP045A(L/-4Z/7W)	6200ZZ	6200ZZ
VKP055A(-4Z/7W)	6200ZZ	6200ZZ
VKP065A(-4Z/7W)	6200ZZ	6200ZZ
VKP075A(-4Z/7W)	6202ZZ	6200ZZ
VKP075AH(-7W)	6204ZZ	6200ZZ
VKP075AK(-7W)	6206ZZ	6200ZZAC
VKP075J(-7W)	6202ZZ	6200ZZ
VKP085A(-4Z/7W)	6204ZZ	6200ZZ
VKP085AF(-7W)	6204ZZ	6200ZZ
VKP085AK(-7W)	6206ZZ	6200ZZAC
VKP085J(-7W)	6202ZZ	6200ZZ
VKP095A(-4Z/7W)	6204ZZ	6202ZZ
VKP095AF(-7W)	6204ZZ	6202ZZ
VKP095AK(-7W)	6206ZZ	6202ZZAC
VKP095J(-7W)	6204ZZ	6202ZZ
VKP115A(-7W)	6305ZZ	6203ZZ
VKP115A(-e/4Z/7W/-4Z-e)	6305ZZ	6203ZZ
VKP055H	6200ZZ	6200ZZ
VKP065H(-7W)	6200ZZ	6200ZZ
VKP075H(-7W)	6303ZZ	6200ZZ
VKP085H	6204ZZ	6200ZZ
VKP095H(-7W)	6204ZZ	6202ZZ

Selection chart

VKP-A type

(Values at kinematic viscosity 1mm<sup>2</sup>/s, specific gravity 1)  
(Values at kinematic viscosity 75mm<sup>2</sup>/s, specific gravity 1)

Synchronous rotating speed 50Hz : 3000min<sup>-1</sup>  
60Hz : 3600min<sup>-1</sup>

●VKP035L

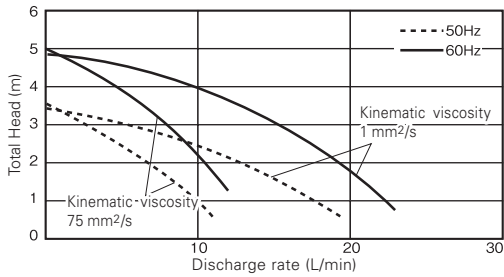

●VKP045A (L)

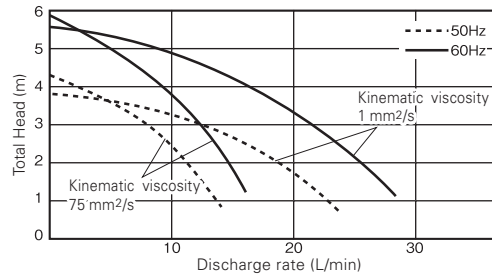

●VKP055A

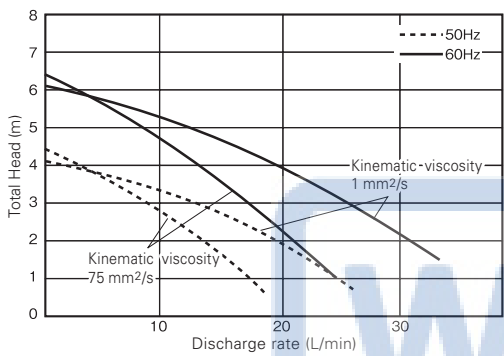

●VKP065A

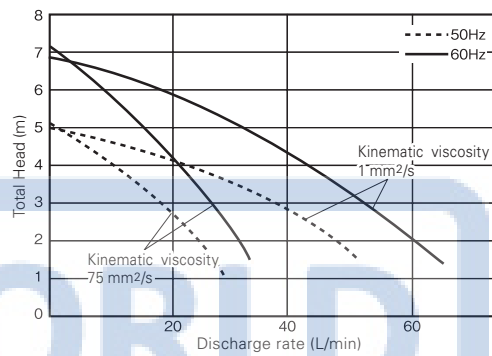

●VKP075A (AH/AK/J)

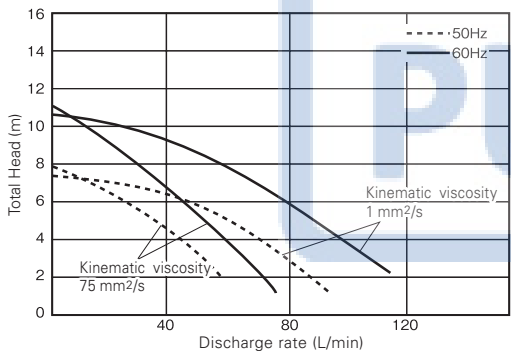

●VKP085A (AF/AK/J)

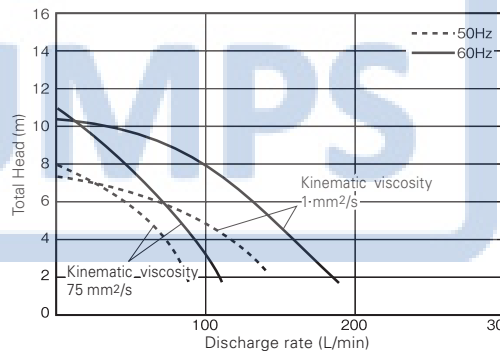

●VKP095A (AF/AK/J)

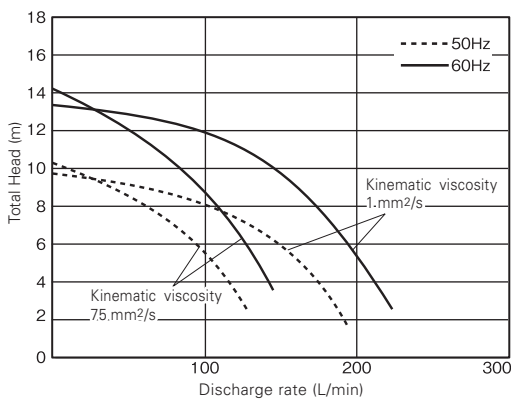

●VKP115A

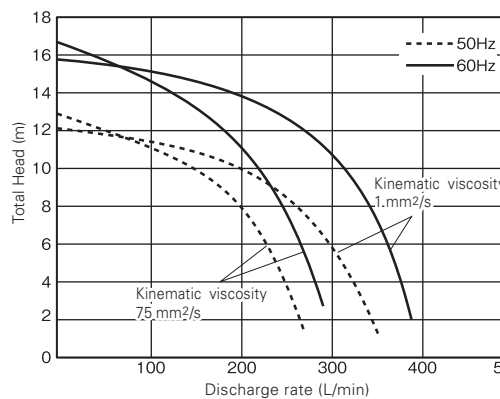

※ This also applies to -e/4Z/7W type.

Note 1) Take note that discharge rate varies considerably depending on the type and kinematic viscosity of liquid.

Note 2) There is virtually no change in characteristics according to leg length (LH130 to 350mm).

VKP-H type

(Values at kinematic viscosity 1mm<sup>2</sup>/s, specific gravity 1)

Synchronous rotating speed 50Hz : 3000min<sup>-1</sup>  
60Hz : 3600min<sup>-1</sup>

●VKP055H

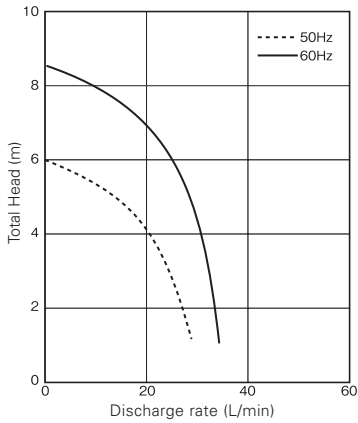

●VKP065H

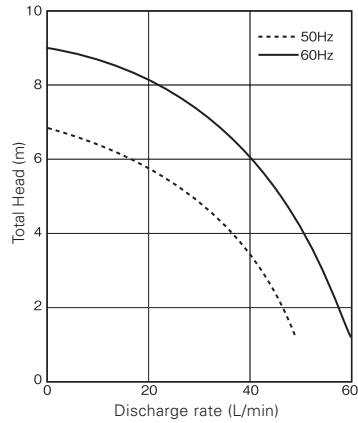

●VKP075H

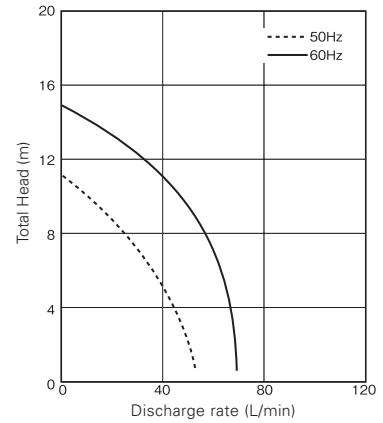

●VKP085H

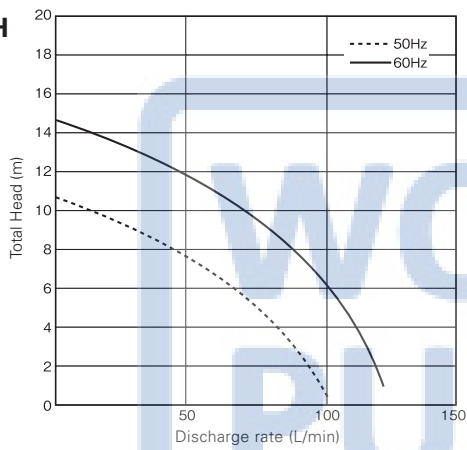

●VKP095H

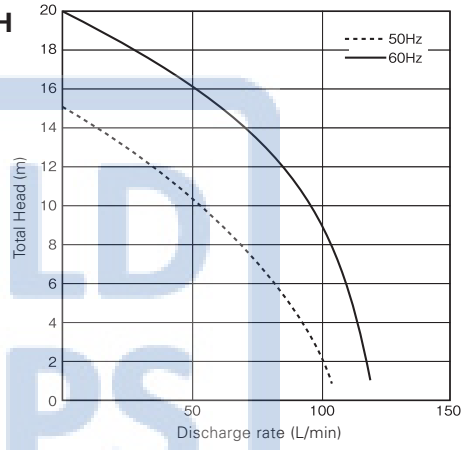

※ This also applies to -7W type.

Note 1) Please note that discharge rate varies considerably depending on the type and kinematic viscosity of liquid.

Specification table

VKP-A type

Bore diameter (Rp)	Type	Output (W)	50Hz					60Hz					Protection method	Thermal class			
			Rated voltage (V)	Rated current (A)	Starting current (A)	Discharge (L/min)	Total head (m)	Rated voltage (V)	Rated current (A)	Starting current (A)	Discharge (L/min)	Total head (m)					
1/4	VKP035L*	20	200	0.18	0.67	13	2	200/220	0.2/0.2	0.62/0.68	19	2	IP23	B			
	VKP045L*	40	200	0.32	1.38	19	1.5	200/220	0.31/0.31	1.24/1.36	25	1.5					
	VKP045A																
	VKP045A-4Z																
VKP045A-7W							208/230/460	0.28/0.29/0.15	1.3/1.5/0.75								
3/8	VKP055A	60	200	0.4	1.73	20	2	200/220	0.35/0.35	1.52/1.67	30	2	IP54	B			
	VKP055A-4Z		380/400/415	0.19/0.20/0.22	0.8/0.9/0.9			400/440	0.18/0.18	0.7/0.8							
	VKP055A-7W				208/230/460	0.39/0.38/0.19	1.8/2.0/1.0										
	VKP065A	100	200	0.55	2.67	45	2	200/220	0.5/0.5	2.33/2.56	60	2					
	VKP065A-4Z		380/400/415	0.28/0.28/0.29	1.2/1.3/1.3			400/440	0.25/0.25	1.1/1.3							
VKP065A-7W					208/230/460			0.56/0.55/0.28	3/3.3/1.7								
1/2	VKP075A	180	200	0.85	5.86	75	3	200/220	1.0/1.0	5.52/6.08	100	3	IP54	B			
	VKP075AH																
	VKP075AK																
	VKP075J							200/220	1.0/1.0	5.52/6.08	95						
	VKP075A-4Z							380/400/415	0.44/0.43/0.42	2.0/2.1/2.1	400/440				0.5/0.5	1.9/2.1	100
VKP075A-7W				208/230/460	1.0/0.95/0.48	5.4/6/3											
3/4	VKP085A	250	200	1.2	8.79	110	4	200/220	1.5/1.5	8.26/9.09	160	4	IP54	B			
	VKP085AF																
	VKP085AK																
	VKP085J							200/220	1.5/1.5	8.26/9.09	145						
	VKP085A-4Z							380/400/415	0.65/0.6/0.6	2.9/3.1/3.2	400/440				0.75/0.75	2.9/3.2	160
VKP085A-7W				208/230/460	1.4/1.3/0.65	10.1/10.7/5.4											
1	VKP095A	400	200	2.4	11.0	140	5	200/220	2.5/2.4	10.0/11.0	200	5	IP54	B			
	VKP095AF																
	VKP095AK																
	VKP095J							200/220	2.5/2.4	10.0/11.0							
	VKP095A-4Z							380/400/415	1.2/1.2/1.2	5.2/5.5/5.7					140	400/440	1.3/1.2
VKP095A-7W				208/230/460	2.3/2.2/1.1	13.4/15.2/7.6											
2	VKP115A	750	200	3.3	25.7	165	7	200/220	3.7/3.6	23.3/25.7	285	7	IP54	B			
	VKP115A-e							200/220	3.7/3.6	28.0/30.0							
	VKP115A-4Z							380/400/415	1.7/1.7/1.7	11.1/11.7/12.1					400/440	1.9/1.8	10.6/11.6
	VKP115A-4Z-e							380/400/415	1.7/1.7/1.7	13.5/14.5/15.3					400/440	1.9/1.9	14.0/15.0
	VKP115A-7W														208/230/460	3.7/3.6/1.9	28.8/32.0/16.0

Note 1) Since VKP035L and VKP045L have cabtyre cable, these models do not comply with CE Marking. Additionally, protection method is IP23.

Note 2) Discharge rate and total head are the values obtained in the tests with a liquid viscosity of 1mm<sup>2</sup>/s (same as fresh water at normal temperature). Please note that the pump cannot use water.

Note 3) VKP □□□ J, VKP115A(-□) are bottom suction type.

Note 4) The pump's rated current (current value listed on the pump nameplate) is the recommended current setting for protection device.

VKP-H type

Bore diameter (Rp)	Type	Output (W)	50Hz					60Hz					Protection method	Thermal class
			Rated voltage (V)	Rated current (A)	Starting current (A)	Discharge rate (L/min)	Total head (m)	Rated voltage (V)	Rated current (A)	Starting current (A)	Discharge rate (L/min)	Total head (m)		
3/8	VKP055H	60	200	0.42	1.73	10	5	200/220	0.55/0.52	1.52/1.67	10	7.5	IP54	B
	VKP065H	100	200	0.55	2.67	10	5.5	200/220	0.6/0.6	2.33/2.56		8		
	VKP065H-7W											208/230/460		
1/2	VKP075H	180	200	0.9	5.86	20	9	200/220	1.2/1.1	5.52/6.08	20	13	IP54	B
	VKP075H-7W							208/230/460	1/0.95/0.48	5.4/6/3				
3/4	VKP085H	250	200	1.2	8.79	20	9	200/220	1.5/1.5	8.26/9.09	20	8	IP54	B
	VKP095H							200/220	2.5/2.4	10.0/11.0				
1	VKP095H-7W	400						208/230/460	2.3/2.2/1.1	13.4/15.2/7.6				F

Note 1) Discharge rate and total head are the values obtained in the tests with a liquid viscosity of 1mm<sup>2</sup>/s (same as fresh water at normal temperature). Please note that the pump cannot use water.

Note 2) The pump's rated current (current value listed on the pump nameplate) is the recommended current setting for protection device.

Assembly drawing

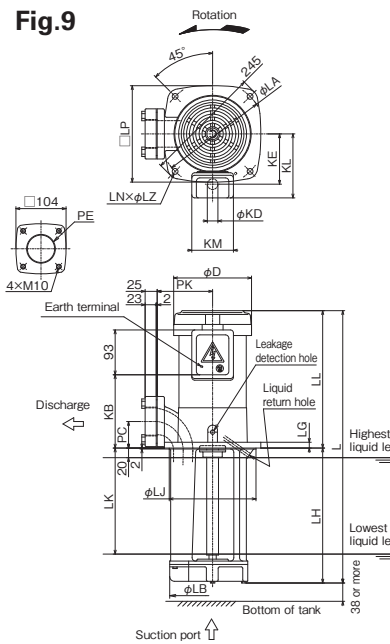
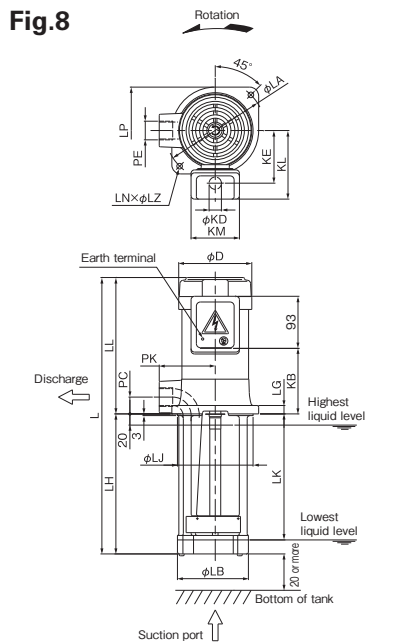
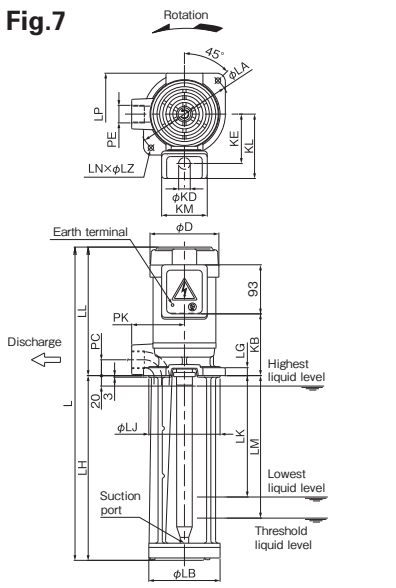
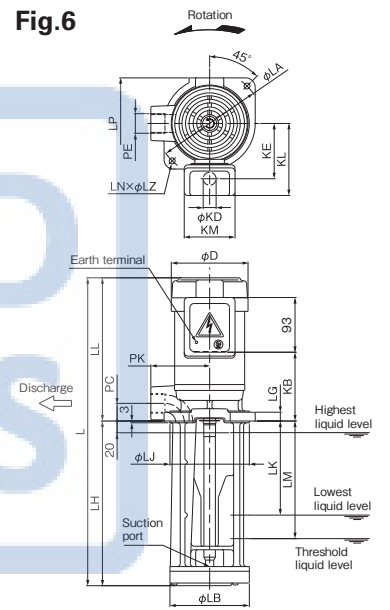
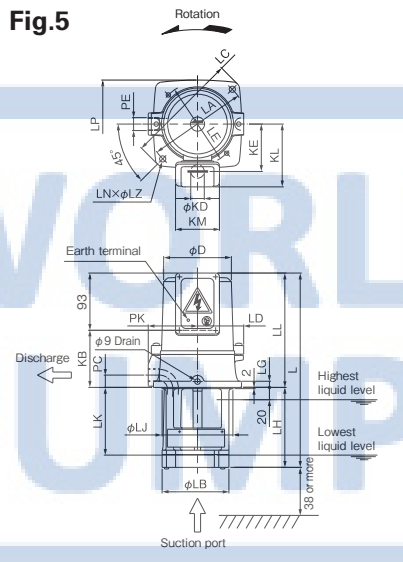
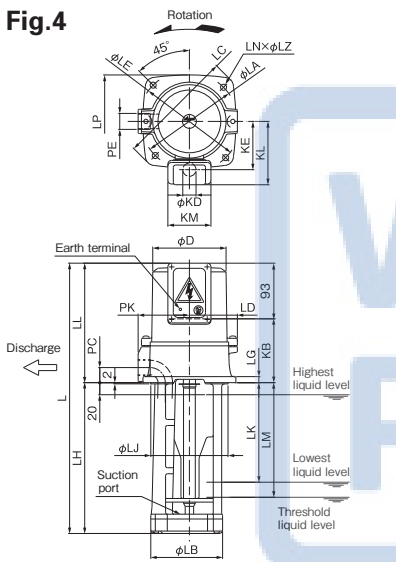
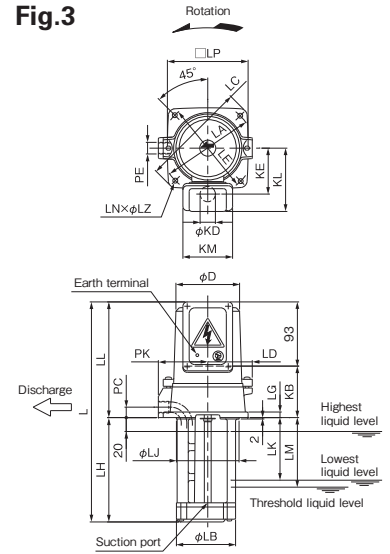
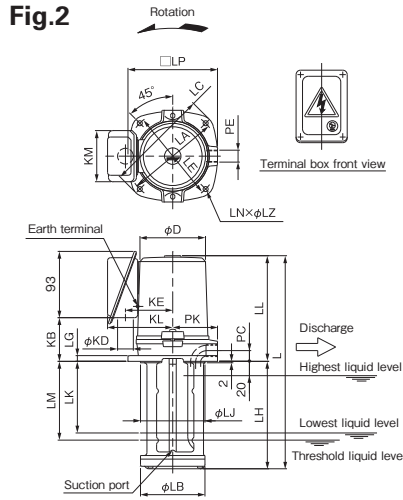
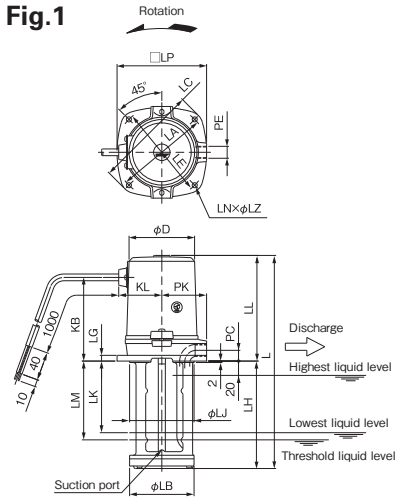



Fig.10

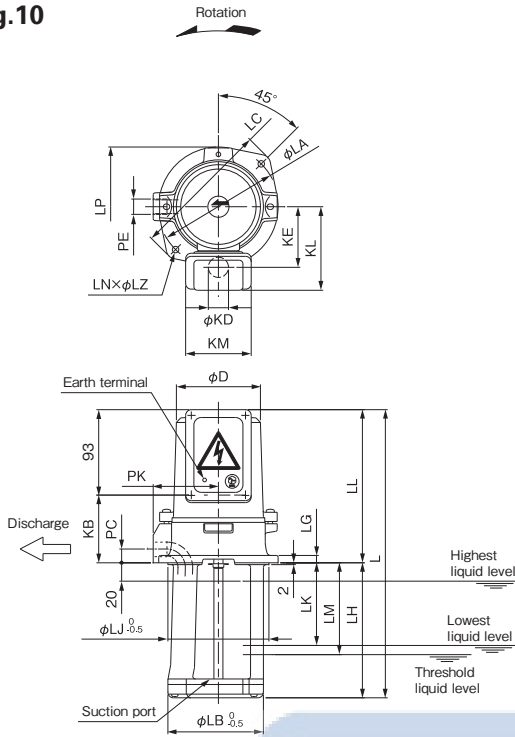
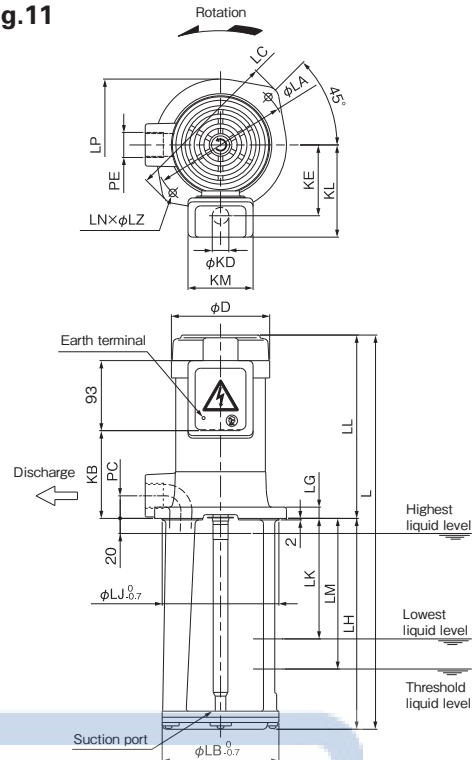

Fig.11



Dimensions

VKP-A type

(Unit : mm)

Type	Fig.	D	KB	KD	KE	KL	KM	L	LA	LB	LC	LD	LE	LG	LH	LJ	LK	LL	LM	LN	LP	LZ	PC	PE	PK	Approx. mass (kg)
VKP035L	1	92	115.5	—	—	61	—	296	130	90 <sup>0</sup> <sub>0.5</sub>	143	—	130	8	148	90 <sup>0</sup> <sub>0.5</sub>	105	148	115	4	125	7	15	Rp 1/4	62.5	5.5
VKP045L	1	92	115.5	—	—	61	—	298	130	90 <sup>0</sup> <sub>0.5</sub>	143	—	130	8	150	90 <sup>0</sup> <sub>0.5</sub>	100	148	110	4	125	7	15	Rp 1/4	62.5	5.5
VKP045A (-4Z/7W)	2	92	60.5	22	67	93	73	298*	130	90 <sup>0</sup> <sub>0.5</sub>	145	—	130	8	150	90 <sup>0</sup> <sub>0.5</sub>	100	148*	110	4	125	7	15	Rp 1/4	62.5	5.5
VKP055A (-4Z/7W)	3	92	74	22	67	93	73	317	132	90 <sup>0</sup> <sub>0.5</sub>	152	64	130	8	150	90 <sup>0</sup> <sub>0.5</sub>	100	167	110	4	116	7	15	Rp 3/8	71	6.0
VKP065A (-4Z/7W)	3	92	74	22	67	93	73	317	132	90 <sup>0</sup> <sub>0.5</sub>	152	64	134	8	150	90 <sup>0</sup> <sub>0.5</sub>	90	167	100	4	116	7	15	Rp 3/8	71	6.5
VKP075A (-4Z/7W)	3	111	94	22	78	104	73	367	160	115 <sup>0</sup> <sub>0.5</sub>	184	75	134	10	180	115 <sup>0</sup> <sub>0.5</sub>	105	187	130	2	143	19	20	Rp 1/2	80	10.0
VKP075J (-7W)	5	111	94	22	78	104	73	317	160	115 <sup>0</sup> <sub>0.5</sub>	184	75	134	10	130	115 <sup>0</sup> <sub>0.5</sub>	110	187	110	2	143	10	20	Rp 1/2	80	11.0
VKP075AH (-7W)	3	111	94	22	78	104	73	437	160	115 <sup>0</sup> <sub>0.5</sub>	184	75	134	10	250	115 <sup>0</sup> <sub>0.5</sub>	175	187	200	2	143	10	20	Rp 1/2	80	10.0
VKP075AK (-7W)	3	111	107	22	78	104	73	550	160	115 <sup>0</sup> <sub>0.5</sub>	184	75	134	10	350	115 <sup>0</sup> <sub>0.5</sub>	275	200	300	2	143	10	20	Rp 1/2	80	11.0
VKP085A (-4Z/7W)	4	122	106	22	81	107	73	449	160	128 <sup>0</sup> <sub>0.5</sub>	194	80	170	10	250	128 <sup>0</sup> <sub>0.5</sub>	165	199	190	4	154	10	25	Rp 3/4	85	15.0
VKP085J (-7W)	5	122	106	22	81	107	73	329	160	128 <sup>0</sup> <sub>0.5</sub>	194	80	170	10	130	128 <sup>0</sup> <sub>0.5</sub>	105	199	—	4	154	10	25	Rp 3/4	85	16.0
VKP085AF (-7W)	3	122	106	22	81	107	73	379	160	128 <sup>0</sup> <sub>0.5</sub>	194	80	170	10	180	128 <sup>0</sup> <sub>0.5</sub>	95	199	120	4	154	10	25	Rp 3/4	85	15.0
VKP085AK (-7W)	3	122	116	22	81	107	73	559	160	128 <sup>0</sup> <sub>0.5</sub>	194	80	170	10	350	128 <sup>0</sup> <sub>0.5</sub>	265	209	290	4	154	10	25	Rp 3/4	85	16.0
VKP095A (-4Z/7W)	6	131	117	22	94	122	87	524	180	135 <sup>0</sup> <sub>0.7</sub>	—	—	—	15	280	135 <sup>0</sup> <sub>0.7</sub>	160	244	200	2	155	10	30	Rp1	100	16.5
VKP095J (-7W)	8	131	117	22	94	122	87	494	180	135 <sup>0</sup> <sub>0.7</sub>	—	—	—	15	250	135 <sup>0</sup> <sub>0.7</sub>	225	244	—	2	155	10	30	Rp1	100	17.0
VKP095AF (-7W)	7	131	117	22	94	122	87	424	180	135 <sup>0</sup> <sub>0.7</sub>	—	—	—	15	180	135 <sup>0</sup> <sub>0.7</sub>	60	244	100	2	155	10	30	Rp1	100	17.0
VKP095AK (-7W)	7	131	117	22	94	122	87	594	180	135 <sup>0</sup> <sub>0.7</sub>	—	—	—	15	350	135 <sup>0</sup> <sub>0.7</sub>	230	244	270	2	155	10	30	Rp1	100	18.0
VKP115A (-4Z)	9	162	152	22	105	133	87	565	220	180 <sup>0</sup> <sub>0.7</sub>	—	—	—	12	280	180 <sup>0</sup> <sub>0.7</sub>	220	285	—	4	200	12	55	Rp2	115	27.0
VKP115A-e (-4Z/7W)	9	162	152	22	105	133	87	565	220	180 <sup>0</sup> <sub>0.7</sub>	—	—	—	12	280	180 <sup>0</sup> <sub>0.7</sub>	220	285	—	4	200	12	55	Rp2	115	28.0

\*-7W type: L:296 LL:146

VKP-H type

(Unit : mm)

Type	Fig.	D	KB	KD	KE	KL	KM	L	LA	LB	LC	LG	LH	LJ	LK	LL	LM	LN	LP	LZ	PC	PE	PK	Approx. mass (kg)
VKP055H	10	92	74	22	67	93	73	312	132	110	152	8	145	110	100	167	110	2	130	7	15	Rp 3/8	71	6.0
VKP065H (-7W)		92	74	22	67	93	73	317	132	110	152	8	150	110	90	167	100	2	130	7	15	Rp 3/8	71	6.5
VKP075H (-7W)		111	94	22	78	104	73	367	160	135	180	10	180	135	105	187	130	2	154	10	20	Rp 1/2	80	10.0
VKP085H		122	106	22	81	107	73	449	160	135	180	10	250	135	165	199	190	2	154	10	25	Rp 3/4	85	15.0
VKP095H (-7W)	11	131	117	22	94	122	87	524	180	155	206	15	280	155	160	244	200	2	175	10	30	Rp1	—	16.5

Detailed drawing of the terminal box

●VKP045A (L) ~085A (-4Z)  
VKP055H~085H

Assembly drawing

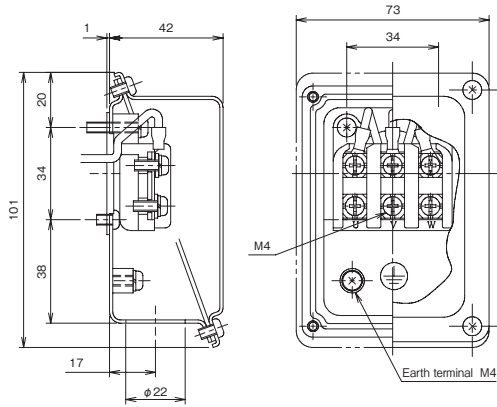

Connection diagram

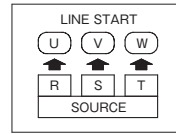

※ For the type whose ID ends with "L," cabtyre cable is used.

●VKP095□ (-4Z), 115A (-e/4Z)

Assembly drawing

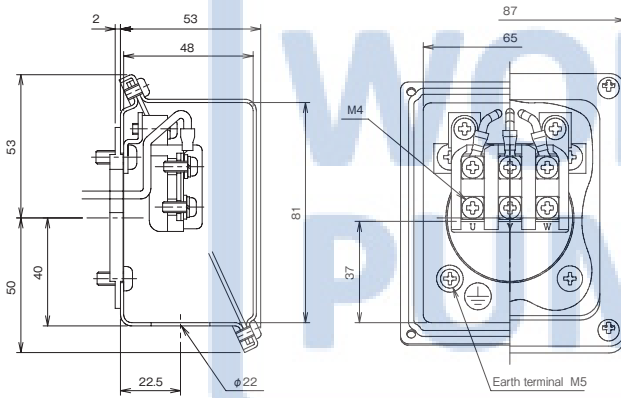

Connection diagram

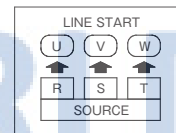

● VKP-7W

Assembly drawing

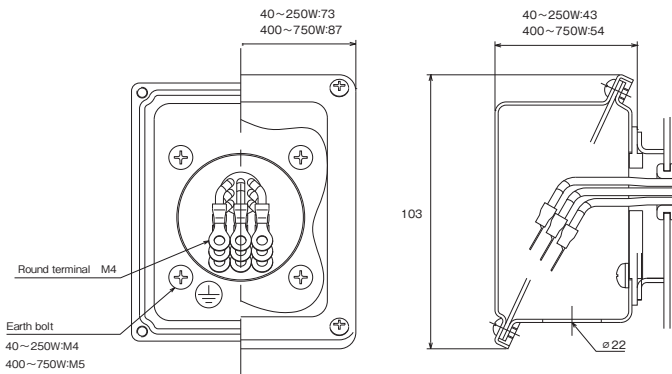

Connection diagram

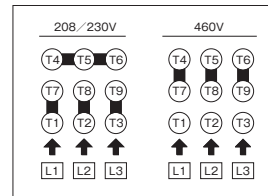

Sectional drawing

● VKP035A (L) ~085A □ (-4Z/7W)  
VKP065H ~085H

● VKP115A (-e/4Z/7W)

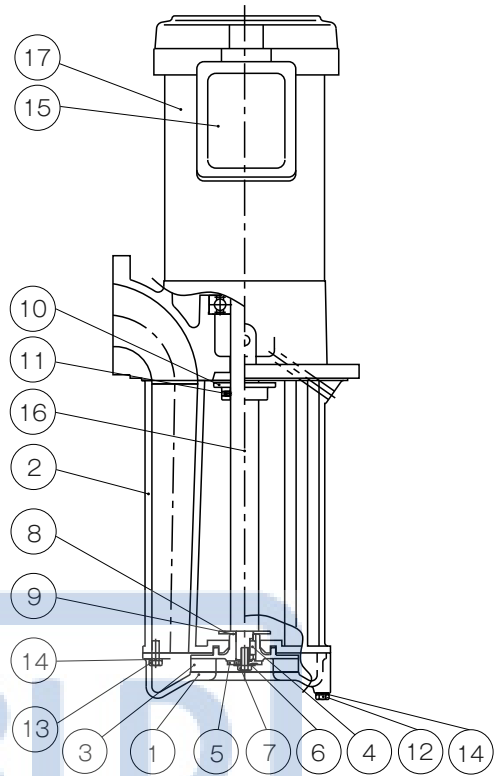
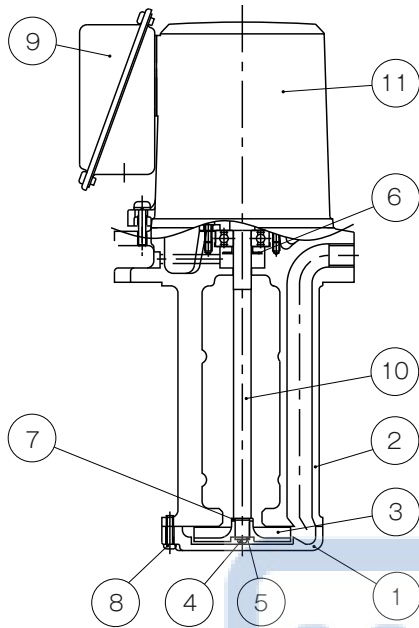

No.	Part name	Material	No.	Part name	Material
1	Inner casing	FC150	7	Adjust seal	BsP3-1/2H
2	Pump leg	FC150	8	Small pan head screw	SU1S302
3	Impeller	Refer to the table below	9	Terminal box	SPCC
4	Small pan head screw	SS	10	Main shaft	S45C
5	Toothed washer	SK5	11	Motor	-
6	Oil thrower	SPCC			

Note 1) For the type whose ID ends with "L," cabtrey cable is used.  
Note 2) The materials in the table above are equivalents.  
Note 3) Structure and other details are subject to change without notice.

No.	Part name	Material	No.	Part name	Material
1	Inner casing	FC150	10	Collar	FC150
2	Pump leg	FC150	11	Hexagon socket set screw	SS
3	Impeller	CAC407	12	Hexagon head bolt	SUS302
4	Key	S45C	13	Hexagon head bolt	SUS302
5	Press washer	SPCC	14	Spring washer	SUS302
6	Clawed washer	SPCC	15	Terminal box	SPCC
7	Impeller fixing bolt	SS	16	Main shaft	S45C
8	Oil thrower	SPHC	17	Motor	-
9	Adjust seal	BsP3-1/2H Phosphor bronze			

Note 1) The materials in the table above are equivalents.  
Note 2) Structure and other details are subject to change without notice.

Table of Materials of impeller

VKP-A type

Type	Material of impeller
VKP035L	CAC407
VKP045L	CAC407
VKP045A(-4Z/7W)	CAC407
VKP055A(-4Z/7W)	CAC407
VKP065A(-4Z/7W)	CAC407
VKP075A(-4Z/7W)	Special resins
VKP075AH(-7W)	Special resins
VKP075AK(-7W)	Special resins
VKP075J(-7W)	CAC407
VKP085A(-4Z/7W)	Special resins
VKP085AF(-7W)	Special resins
VKP085AK(-7W)	Special resins
VKP085J(-7W)	CAC407
VKP095A(-4Z/7W)	Special resins
VKP095AF(-7W)	Special resins
VKP095AK(-7W)	Special resins
VKP095J(-7W)	CAC407
VKP115A(-e/4Z/7W)	CAC407

VKP-H type

Type	Material of impeller
VKP055H	CAC407
VKP065H(-7W)	CAC407
VKP075H(-7W)	CAC407
VKP085H	CAC407
VKP095H(-7W)	CAC407

## Features

- ① The LFE-e model is an energy-saving pump with a Top Runner efficiency (equivalent to IE3) motor.  
(Compatible with connecting dimensions of the conventional LFE model)
- ② High-efficiency pumps designed for energy-saving coolant piping
- ③ Non-seal (mechanical seal-less) structure to provide better durability

## Description of types

**LFE 32 A - 0.25 - 300 -e**

① ② ③ ④ ⑤ ⑥

- ① Model
- ② Bore diameter
- ③ Viscosity of liquid:  
A: for low viscosity liquid
- ④ Output
- ⑤ Immersion depth
- ⑥ Motor efficiency  
None: Standard efficiency (equivalent to IE1)  
-e : Top Runner efficiency (equivalent to IE3)



Please note that the paint color, etc. of the actual unit may partially differ from the photo.

## Standard Specification

Model		LFE	LFE-e
Used liquid	Property of liquid	Water-soluble coolant	
	Temperature	0-60 °C (No frozen liquid)	
	Allowable kinematic viscosity	1mm <sup>2</sup> /s	
Installation location		Indoor Ambient temperature: 0 to 40 °C, RH 85% or below (no condensation), Height above sea level: 1000m or less, Place not exposed to direct sunlight, Place in an area free of corrosive or explosive gas or vapor.	
Material	Section/Discharge casing	FC200	
	Impeller	FCD450	
	Main shaft	S35C	
Sealing structure		Non-seal (mechanical seal-less)	
Motor	Power source	3-phase 60Hz	200/220V
	Output	0.25~0.4kW	0.6~0.75kW
	Type	Totally enclosed self-cooling motor	Totally enclosed fan-cooled, indoor type
	Protection method	IP43	IP44
	Thermal class	F	
	Rating	Continuous	
Number of poles		2P	
Paint color		Munsell N1.5	

## Table of Consumable Parts

Type	O-ring			Bearing		Oil seal
	For discharge bushing	For liner ring	For companion flange	Load side	Unload side	
LFE32A-0.25-300		G65	G50	6205ZZC3	6203ZZC3	G25355
LFE50A-0.35-300	G35	G75	G75			
LFE50A-0.4-300						
LFE50A-0.6-300-e						
LFE65A-0.75-300-e						

## Selection chart

(Values at kinematic viscosity 1mm<sup>2</sup>/s, specific gravity 1)

60Hz only

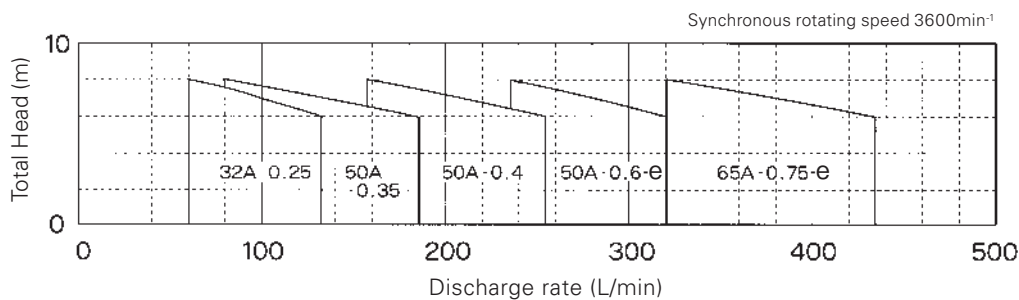

## Specification table

Bore diameter (mm)	Frequency (Hz)	Type	Rated voltage (V)	Output (kW)	Rated current (A)	Starting current (A)	Discharge rate (L/min)	Total head (m)
32	60	LFE32A-0.25-300	200/220	0.25	1.16/1.10	7.2/7.9	60~130	8~6
		LFE50A-0.35-300		0.35	1.90/1.82	13.0/14.0	80~185	
LFE50A-0.4-300		0.4		1.90/1.82	13.0/14.0	160~255		
LFE50A-0.6-300-e		0.6		3.5/3.5	29.0/32.0	235~320		
65		LFE65A-0.75-300-e		0.75	3.5/3.5	29.0/32.0	320~430	

※ The pump's rated current (current value listed on the pump nameplate) is the recommended current setting for protection device.

Assembly drawing

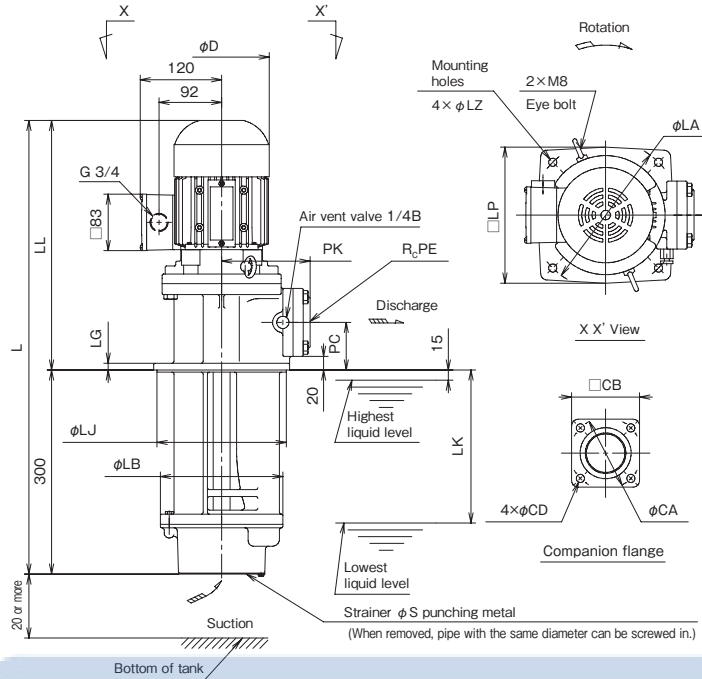

Dimensions

(Unit : mm)

Bore diameter (mm)	Type	PE	D	L	LL	LK	LJ	LB	LG	PK	PC	LP	LZ	LA	S	CA	CB	CD	Approx. mass(kg)
32	LFE32A-0.25-300	1 1/4	157	625.5	325.5	240	160	150	10	120	55	180	10	200	7	70	70	10	29
50	LFE50A-0.35-300	2	157	659.5	359.5	225	190	180	10	130	70	200	12	220	7	105	100	12	34
	LFE50A-0.4-300	2	157	659.5	359.5	225	190	180	10	130	70	200	12	220	7	105	100	12	34
	LFE50A-0.6-300-e	2	140	667	367	225	190	180	10	130	70	200	12	220	7	105	100	12	35
65	LFE65A-0.75-300-e	2 1/2	140	692	392	200	220	210	12	150	80	230	15	250	8	125	120	15	42

Detailed drawing of the terminal box    Sectional drawing

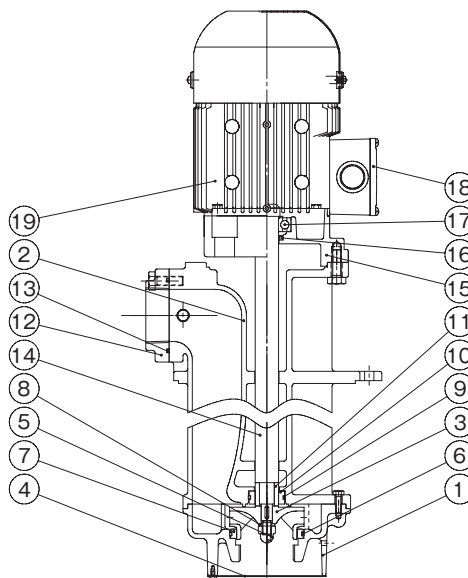
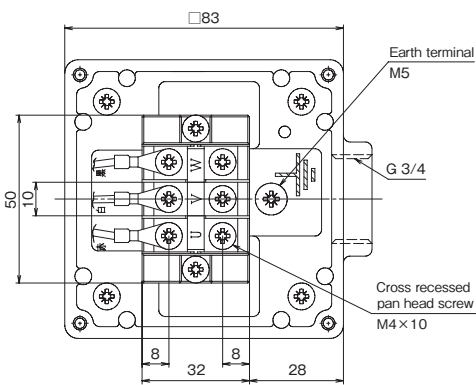

No.	Part name	Qty	Material
1	Suction casing	1	FC200
2	Discharge casing	1	FC200
3	Impeller	1	FCD450
4	Strainer	1	SUS304*
5	Impeller nut	1	SUS304
6	O-ring	1	NBR
7	Liner ring	1	PTFE
8	Washer	1	SUS304
9	O-ring	1	NBR
10	Discharge bushing	1	PTFE
11	Shaft sleeve	1	SUS304
12	Companion flange	1	FC200
13	O-ring	1	NBR
14	Main shaft	1	S35C
15	Motor bracket	1	FC200
16	Oil seal	1	NBR
17	Load-side bearing	1	SUJ2
18	Terminal box	1	ADC
19	Motor	1	

\* SS400 for LFE65-e.

Note 1) The materials in the table above are equivalents.

Note 2) Structure and other details are subject to change without notice.

Features

- ① Energy-saving pump with a Top Runner efficiency (equivalent to IE3) motor.
- ② Though it is small, it is specified for high-pressure.
- ③ With a non-seal (mechanical-seal-less) structure, it is highly durable.
- ④ Special reliable resin is used in the main part of the pump.
- ⑤ Its mounting dimension is compatible with conventional pumps.

Description of types

**LHW 20 3 A 0.75 -e**

① ② ③ ④ ⑤ ⑥

- ① Model
- ② Bore diameter
- ③ Number of impellers
- ④ Viscosity of the liquid  
A : for low viscosity liquid
- ⑤ Output
- ⑥ Top Runner efficiency(equivalent to IE3)



Please note that the paint color, etc. of the actual unit may partially differ from the photo.

Standard Specification

Used liquid	Property of liquid	Water-soluble coolant, cleaning liquid (weak alkaline)
	Temperature	0-60 °C (No frozen liquid)
	Allowable kinematic viscosity	1mm <sup>2</sup> /s
Installation location		Indoor Ambient temperature: 0 to 40 °C, RH 85% or below (no condensation), Height above sea level : 1000m or less, Place not exposed to direct sunlight, Place in an area free of corrosive or explosive gas or vapor.
Material	Suction/ Discharge casing	FC200
	Intermediate casing	ARLS
	Impeller	(Special polyamide resin reinforced with glass fiber, etc.)
	Main shaft	equivalent to SUS420J2
Sealing structure		Non-seal (mechanical seal-less)
Motor	Power source	3-phase 50/60/60Hz 200/200/220V
	Type	Totally enclosed fan-cooled, indoor type
	Protection method	IP44
	Thermal class	F
	Rating	Continuous
	Number of poles	2P
Paint color		Munsell N1.5

Selection chart

(Values at kinematic viscosity 1mm<sup>2</sup>/s, specific gravity 1)

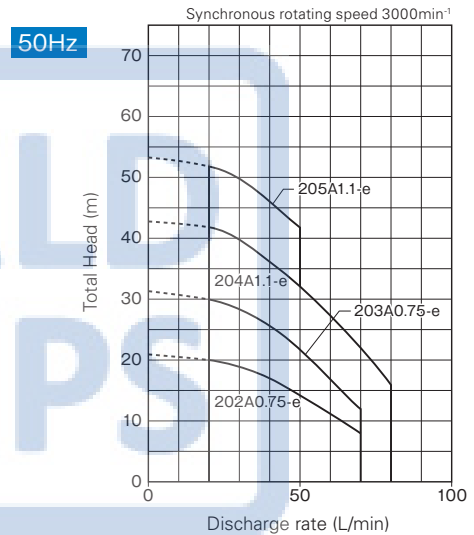

Table of Consumable Parts

Output (kW)	Bearing		Oil seal	V ring	O-ring (for outer cylinder)	O-ring (for discharge casing)
	Load side	Unload side				
0.75	AC6205 ZZ C3	AC6204 ZZ C3	D20387	VR20A	G115	G110
1.1						

Specification table

Frequency (Hz)	Bore diameter (mm)	Type	Rated voltage (V)	Output (kW)	Rated current (A)	Starting current (A)	Discharge rate (L/min)	Total head (m)
50	20	LHW202A0.75-e	200	0.75	3.2	20.4	20~70	20~8
		LHW203A0.75-e		0.75	3.2	20.4	20~70	30~12
		LHW204A1.1-e		1.1	4.4	38.6	20~80	42~16
		LHW205A1.1-e		1.1	4.4	38.6	30	50
60	20	LHW202A0.75-e	200/220	0.75	3.3/3.1	19.0/20.9	20~80	28~9
		LHW203A0.75-e		0.75	3.3/3.1	19.0/20.9	20~80	42~15
		LHW204A1.1-e		1.1	5.1/4.8	34.6/38.1	20~90	59~25
		LHW205A1.1-e		1.1	5.1/4.8	34.6/38.1	30	73

※ The pump's rated current (current value listed on the pump nameplate) is the recommended current setting for protection device.

60Hz

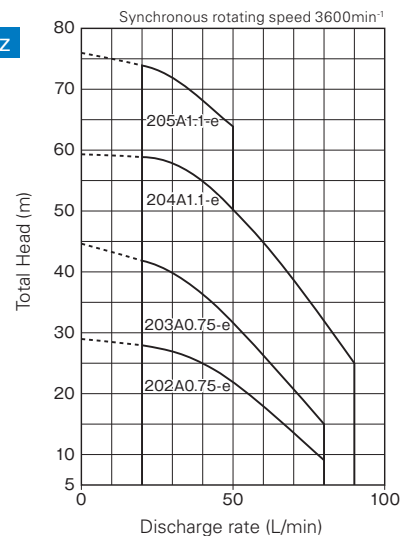

Assembly drawing

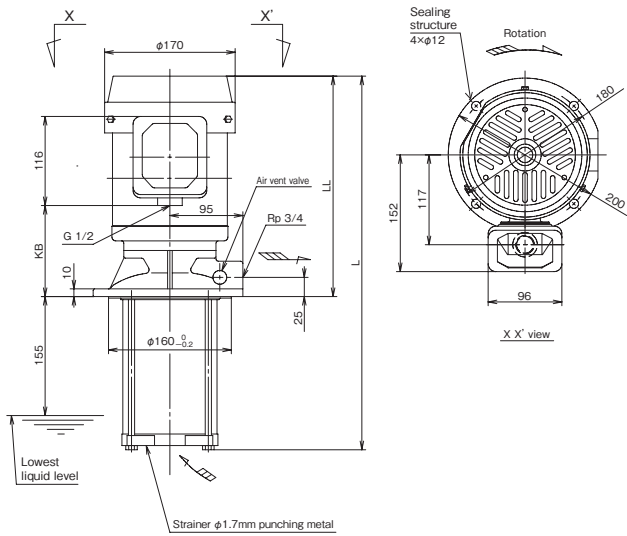

Detailed Drawing of the Terminal Box

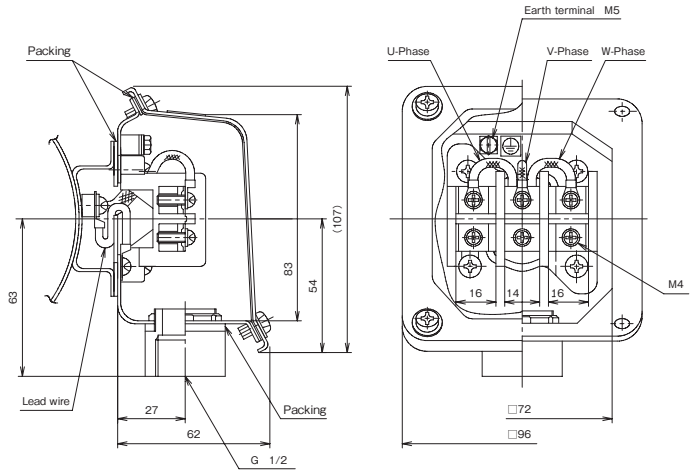

Dimensions

<Unit : mm>

Bore diameter (mm)	Type	KB	L	LL	Approx. mass(kg)
20	LHW202A0.75-e	151	491	291	25
	LHW203A0.75-e	151	491	291	25
	LHW204A1.1-e	178	509	309	28
	LHW205A1.1-e	178	509	309	28

Sectional drawing

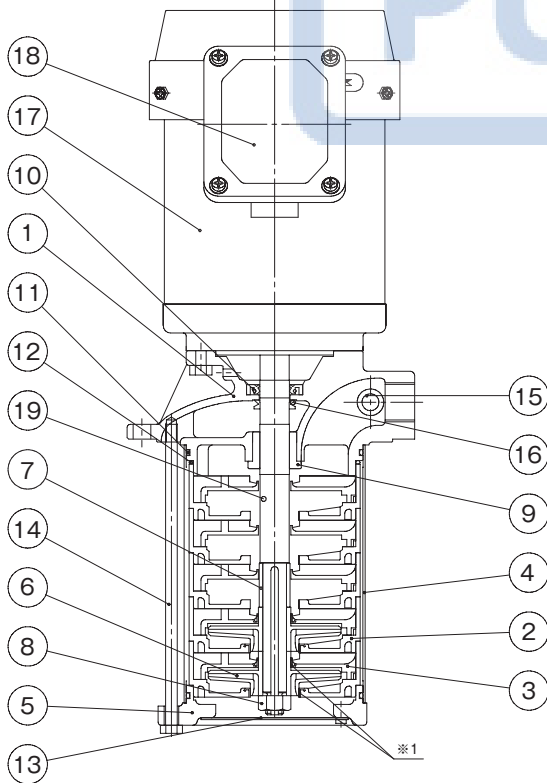

No.	Part name	Qty	Material
1	Discharge casing	1	FC200
2	Intermediate casing	5	ARLS※1
3	Guide vane	5	ARLS※1
4	External cylinder	1	SUS304
5	Suction cover	1	FC200
6	Impeller	n	ARLS
7	Spacer	a	SUS304
8	Impeller nut	1	SUS304
9	Discharge bushing	1	FCD450
10	Oil seal	1	NBR
11	O-ring	2	NBR
12	O-ring	1	NBR
13	Strainer	1	SUS304
14	Through bolt	4	SS400
15	Air vent valve	1	C3604B
16	V ring	1	NBR
17	Motor	1	
18	Terminal box	1	SECC
19	Main shaft	1	SUS420J2

※1 A stainless steel ring is inserted in the guide vane and intermediate casing in which the impeller is fitted.

Note 1) The materials in the table above are equivalents.

Note 2) Structure and other details are subject to change without notice.

n: number of impellers  
 a: number of spacers  
 n=2, 4 → a=1  
 n=3, 5 → a=0

Features

- ① Strong and tough with high wear resistant structure and material.
- ② Non-seal (mechanical seal-less) structure is adopted.
- ③ High-pressure, large-capacity (Max. 500 L/min) pump allows expanded selection of head and discharge rate.
- ④ EU RoHS Directive (RoHS 6 restricted substances) compliant.
- ⑤ EU Directive for CE marking compliant.
- ⑥ Diverse lineup compatible with various efficiencies.  
 VKD type : Equipped with a standard efficiency (IE1) motor.  
 VKD-e type : Equipped with a Top Runner efficiency (equivalent to IE3) motor.  
 VKD-7W type : Equipped with a UL-approved motor (NEMA premium efficiency).
- ⑦ 2 options for immersion length are available (excluding VKD111AA-□).



Please note that the paint color, etc. of the actual unit may partially differ from the photo.

Description of types

VKD 15 1 A D -e

- ①
- ②
- ③
- ④
- ⑤
- ⑥

- ① Model
- ② Output 11:0.75kW, 13:1.5kW, 14:2.2kW, 15:3.0kW
- ③ Series number
- ④ Phase A : 3-phase
- ⑤ Number of impellers, immersion length [standard leg: 260mm (2.2kW or less) /300 mm(3.0kW), Long leg: 400mm]  
 (A: 1 impeller/standard leg, B: 2 impellers/standard leg, C: 3 impellers/standard leg, D: 4 impellers/standard leg,  
 G: 3 impellers/long leg, H: 4 impellers/long leg)
- ⑥ Motor efficiency/ voltage  
 None : Standard efficiency (equivalent to IE1) / Standard voltage  
 -e : Top Runner efficiency (equivalent to IE3) / Standard voltage  
 -4Z : Standard efficiency (equivalent to IE1) / Special voltage  
 -4Z-e : Top Runner efficiency (equivalent to IE3) / Special voltage  
 -7W : UL approved motor (NEMA Premium efficiency)

Standard Specification

Used liquid	Property of liquid	Grinding liquid, cutting liquid, etc., after primary treatment *1
	Temperature	-20 to 40°C (No frozen liquid)
	Allowable kinematic viscosity	75mm <sup>2</sup> /s *2
Installation location		Indoor Ambient temperature: -20 to 40 °C, RH 85% or below (no condensation), Height above sea level : 1000m or less, Place not exposed to direct sunlight, Place in an area free of corrosive or explosive gas or vapor.
Material	Pump leg	FC200
	Casing	FC200
	Impeller	FC200
	Main shaft	S45C
Sealing structure		Non-seal (mechanical seal-less)
Motor	Power source	3-phase 50/60/60Hz 200/200/220V *3
	Type	Totally enclosed fan-cooled, indoor type
	Protection method	IP54
	Thermal class	F
	Rating	Continuous
	Number of poles	2P
	Standard	IEC60034-1 CE Marking *4
Paint color		Munsell N1

Table of Consumable Parts

Type	Bearing		Oil seal		O-ring oil thrower
	Load side	Unload side	Load side	Unload side	
VKD111AA-□	6305ZZ	6203ZZ	SC30457	HM25385	P25
VKD131AB-□	6306ZZ	6205ZZ			P30
VKD141AC-□					
VKD151AD-□	6307ZZ				
VKD131AF-□					
VKD141AG-□					
VKD151AH-□					

\*1 Take note that special liquid such as water, printing liquid or acid liquid cannot be used. Contact us for other special liquid (ceramic, etc.).  
 \*2 -7W type is 1mm<sup>2</sup>/s. In case of using the liquid with kinematic viscosity exceeding 1mm<sup>2</sup>/s, please contact us separately.  
 \*3 -7W type: 60Hz 208/230/460V  
 \*4 Excluding -7W type



Selection chart

(Values at kinematic viscosity 1mm<sup>2</sup>/s, specific gravity 1)  
(Values at kinematic viscosity 75mm<sup>2</sup>/s, specific gravity 1)

Synchronous rotating speed 50Hz : 3000min<sup>-1</sup>  
60Hz : 3600min<sup>-1</sup>

Standard leg

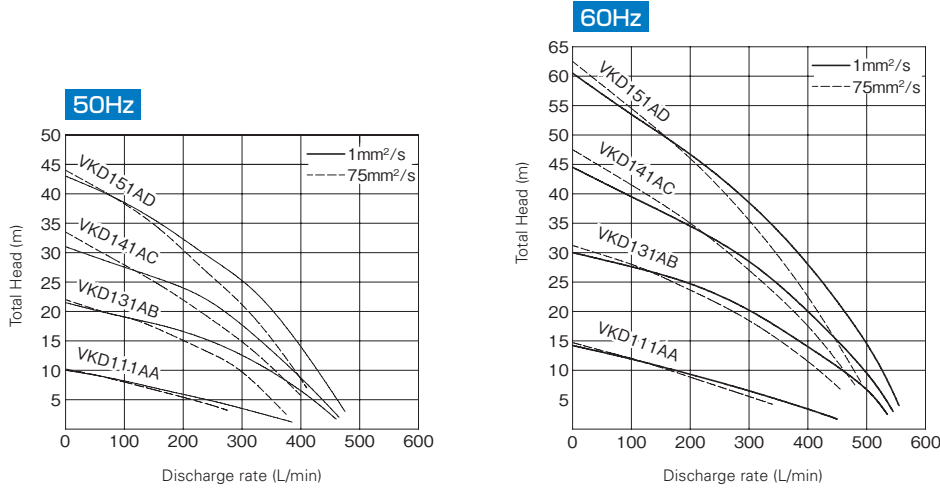

Long leg

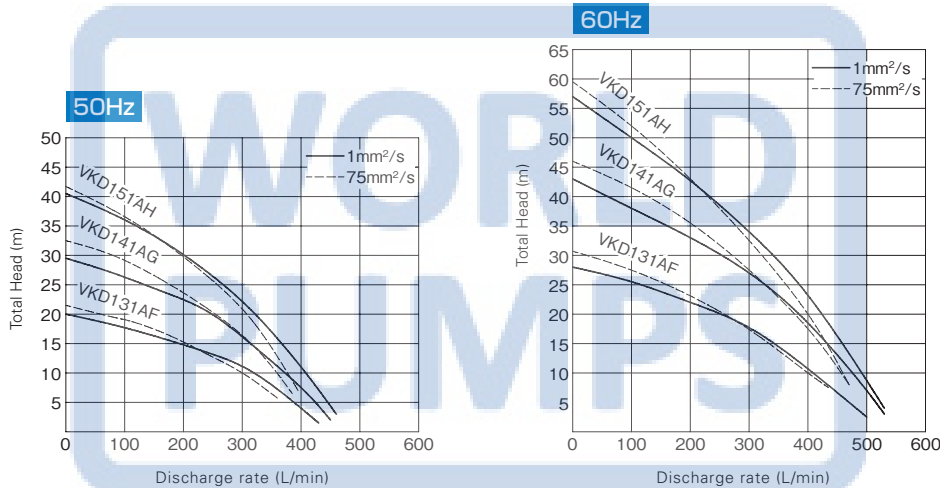

※ This also applies to -e/7W type. However, please contact us for kinematic viscosity 75mm<sup>2</sup>/s.  
Note) Take note that discharge rate varies considerably depending on the type and kinematic viscosity of liquid.

Specification table

Immersion depth	Type	Output (kW)	50Hz					60Hz				
			Rated voltage (V)	Rated current (A)	Starting current (A)	Discharge rate (L/min)	Total head (m)	Rated voltage (V)	Rated current (A)	Starting current (A)	Discharge rate (L/min)	Total head (m)
Standard leg	VKD111AA	0.75	200	4.7	33.8	80~300	8~4	200/220	5.0/4.9	31.1/34.1	100~400	12~4
	VKD111AA-e			4.7	34				5.0/4.9	32.5/36.0		
	VKD111AA-7W								208/230/460	4.3/4.0/2.0		
	VKD131AB	1.5	200	7.6	51.4	80~400	20~7	200/220	10.0/9.2	45.0/49.6	80~400	28~7
	VKD131AB-e			7.6	49				9.1/7.9	45.5/50.0		
	VKD131AB-7W								208/230/460	8.7/8.0/4.0		
	VKD141AC	2.2	200	13.7	92.6	80~400	29~9	200/220	13.6/13.2	80.7/88.8	100~500	40~9
	VKD141AC-e			12	78				12.1/10.7	72.0/79.0		
	VKD141AC-7W								208/230/460	11.7/10.7/5.3		
	VKD151AD	3.0	200	16	92.5	80~400	40~14	200/220	17.3/16.0	80.7/88.9	100~500	54~14
VKD151AD-e	14.5			120	16.2/14.6				115/126			
VKD151AD-7W				208/230/460	15.3/14.0/7.0				119/130/65.0			
Long leg	VKD131AF	1.5	200	7.6	51.4	80~400	18~4	200/220	10.0/9.2	45.0/49.6	100~500	25~2
	VKD131AF-e			7.6	49				9.1/7.9	45.5/50.0		
	VKD131AF-7W								208/230/460	8.7/8.0/4.0		
	VKD141AG	2.2	200	13.7	92.6	80~400	27~7	200/220	13.6/13.2	80.7/88.8	100~500	38~7
	VKD141AG-e			12	78				12.1/10.7	72.0/79.0		
	VKD141AG-7W								208/230/460	11.7/10.7/5.3		
	VKD151AH	3.0	200	16	92.5	80~400	37~11	200/220	17.3/16.0	80.7/88.9	100~500	50~8
	VKD151AH-e			14.5	120				16.2/14.6	115/126		
VKD151AH-7W				208/230/460	15.3/14.0/7.0				119/130/65.0			

Note 1) Discharge rate and total head are the values obtained in the tests with a liquid viscosity of 1mm<sup>2</sup>/s (same as fresh water at normal temperature). Note that the pumps cannot be used with water.  
Note 2) The pump's rated current (current value listed on the pump nameplate) is the recommended current setting for protection device.

Assembly drawing

Standard leg

Fig.1

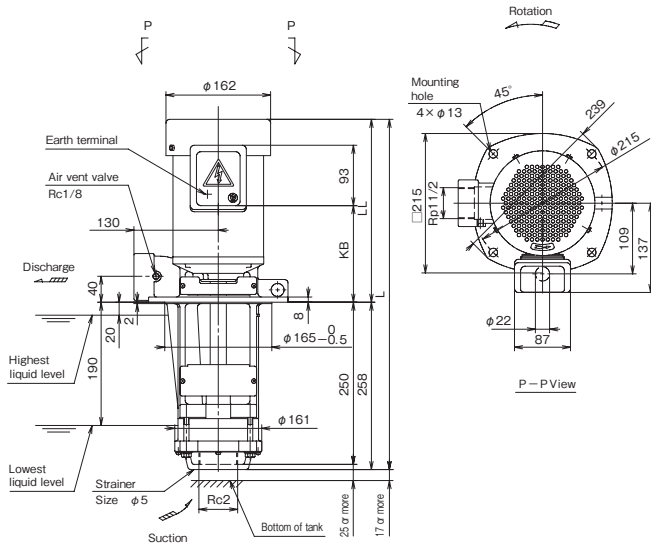
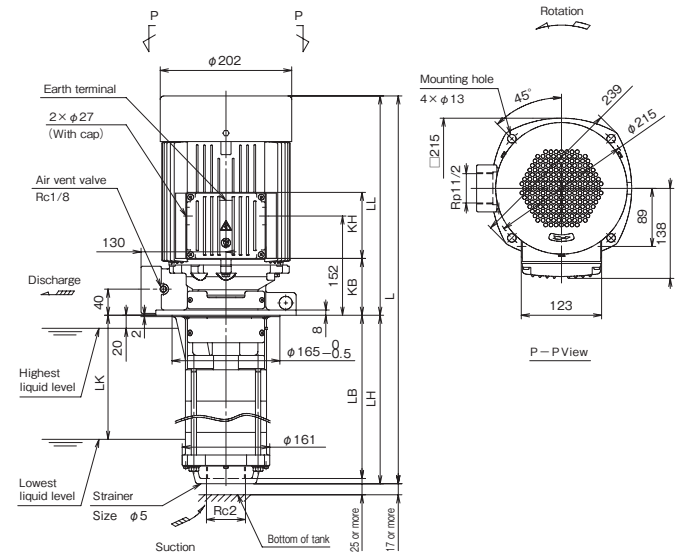
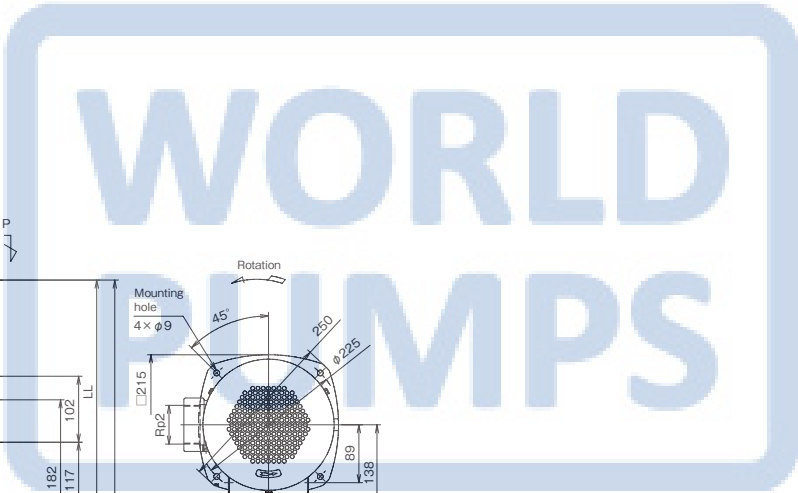
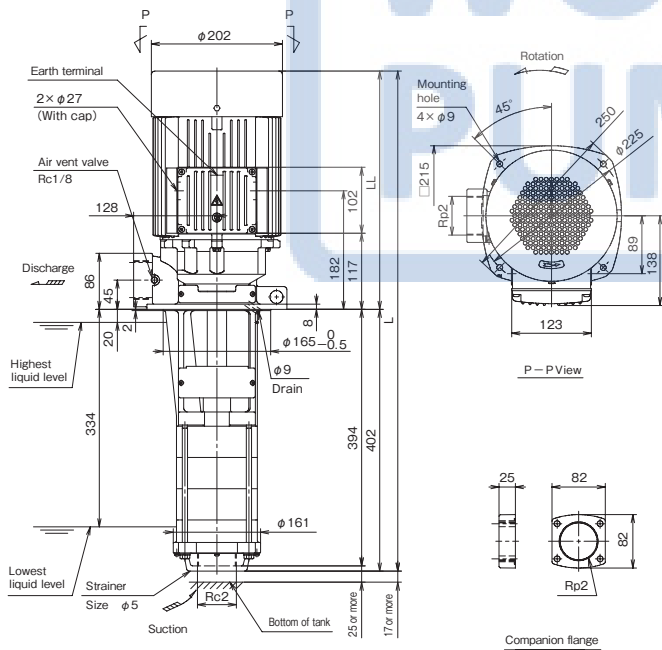

Fig.2



Long leg

Fig.3



■ Dimensions

● Standard leg

(Unit : mm)

Type	Fig.	KB	KH	LB	LH	LK	LL	L	Approx. mass(kg)
VKD111AA	1	139					272	530	24
VKD111AA-e(-7W)	1	149					282	540	25
VKD131AB	2	87	102	250	258	190	336	594	34
VKD131AB-e(-7W)	2	87	102	250	258	190	336	594	35
VKD141AC	2	87	102	250	258	190	336	594	36
VKD141AC-e(-7W)	2	87	102	250	258	190	336	594	37
VKD151AD	2	87	102	298	306	238	336	642	39
VKD151AD-e(-7W)	2	87	102	298	306	238	364	670	45

● Long leg

(Unit : mm)

Type	Fig.	LL	L	Approx. mass(kg)
VKD131AF	3	366	768	40
VKD131AF-e(-7W)	3	366	768	41
VKD141AG	3	366	768	43
VKD141AG-e(-7W)	3	366	768	44
VKD151AH	3	366	768	44
VKD151AH-e(-7W)	3	394	796	50

■ Detailed drawing of the terminal box

● 111AA (-e)

■ Assembly drawing

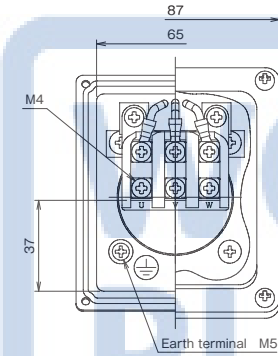
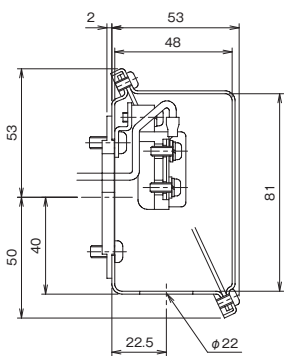

■ Connection diagram

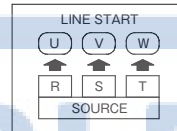

● 131AB (-e) / 141AC (-e) / 151AD (-e)

● 131AF (-e) / 141AG (-e) / 151AH (-e)

■ Assembly drawing

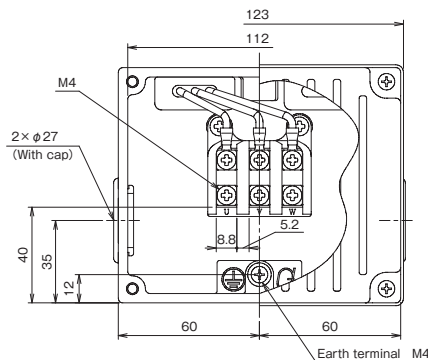
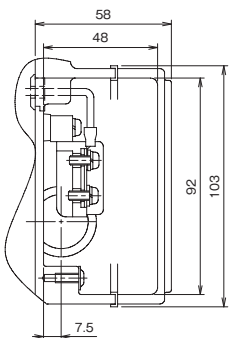

■ Connection diagram

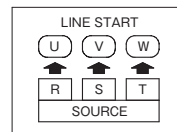

■ Detailed drawing of the terminal box

●VKD-7W 0.75kW

■ Assembly drawing

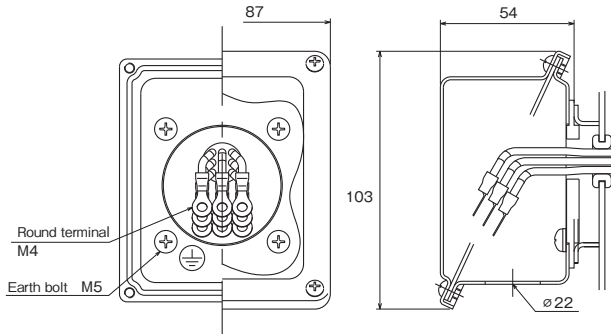

■ Connection diagram

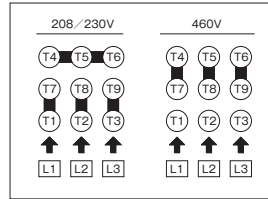

●VKD-7W 1.5kW and above

■ Assembly drawing

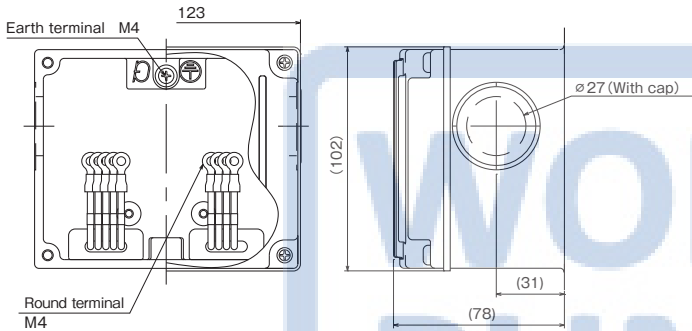

■ Connection diagram

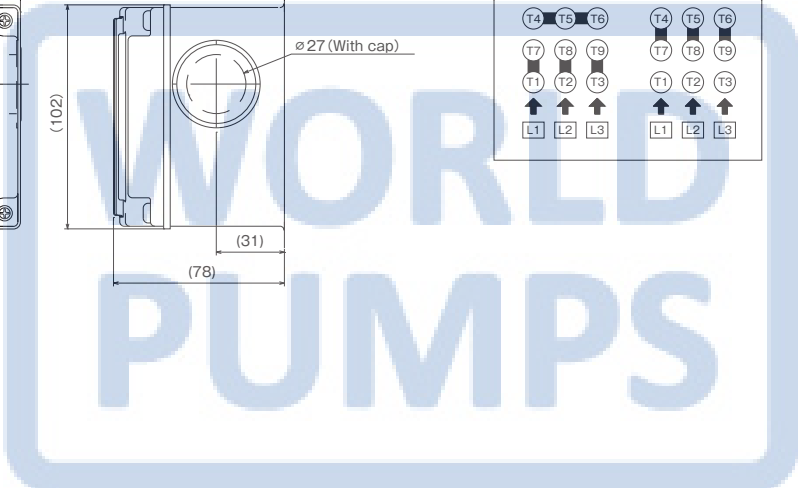
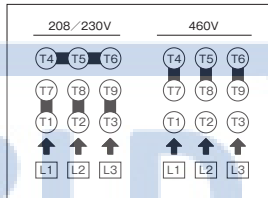

Sectional drawing

●VKD111AA (-□)

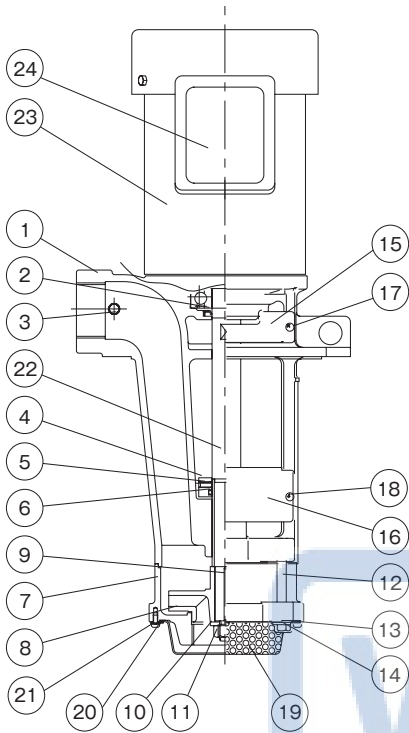

No.	Part name	Material
1	Pump leg	FC200
2	Oil seal	NBR
3	Air vent valve	SUS
4	Oil thrower	SUS304
5	Hexagon socket set screw	SCM435
6	O-ring	FPM
7	Casing	FC200
8	Impeller	FC200
9	Key	S45C-D
10	Plain washer	SPCC
11	Hexagon nut	SS
12	Fastening bolt	SS
13	Plain washer	SPCC
14	Spring washer	SWRH62
15	Side plate	SPCC
16	Side plate	SPCC
17	Pan head screw	SS
18	Pan head screw	SS
19	Strainer	SPCC
20	Holding metal	SPCC
21	Pan head screw with captive washer	SS
22	Main shaft	S45C
23	Motor	—
24	Terminal box	SPCC

Note 1) The materials in the table above are equivalents.  
Note 2) Structure and other details are subject to change without notice.

●VKD131AB (-□) / VKD141AC (-□) /  
VKD151AD (-□)

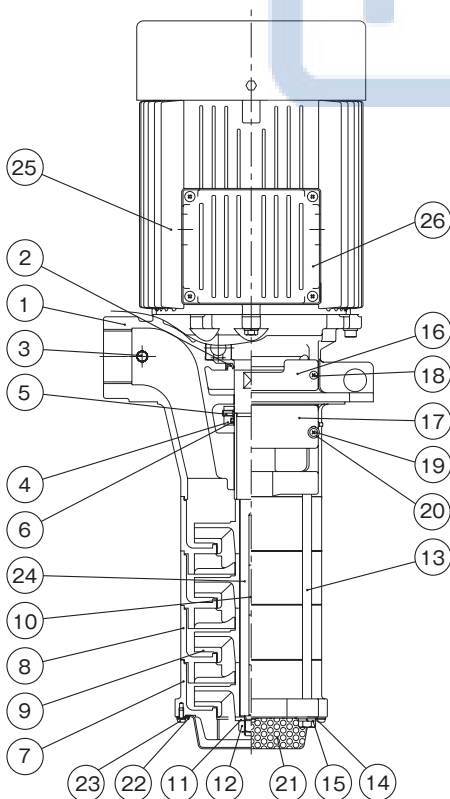

●VKD131AF (-□) / VKD141AG (-□) /  
VKD151AH (-□)

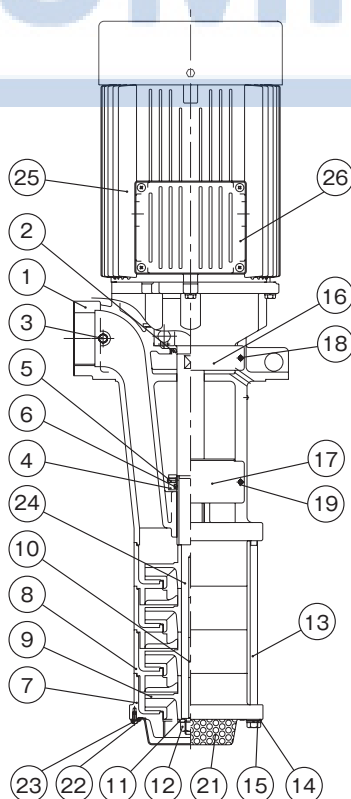

No.	Part name	Material
1	Pump leg	FC200
2	Oil seal	NBR
3	Air vent valve	SUS
4	Oil thrower	SUS304
5	Hexagon socket set screw	SCM435
6	O-ring	FPM
7	Casing	FC200
8	Casing	FC200
9	Impeller	FC200
10	Key	S45C-D
11	Plain washer	SPCC
12	Hexagon nut	SS
13	Fastening bolt	SS
14	Plain washer	SPCC
15	Spring washer	SWRH62
16	Side plate	SPCC
17	Side plate	SPCC
18	Pan head screw	SS
19	Pan head screw	SS
20	Plain washer	SPCC
21	Strainer	SPCC
22	Holding metal	SPCC
23	Pan head screw with captive washer	SS
24	Main shaft	S45C
25	Motor	—
26	Terminal box	ADC12

Note 1) The materials in the table above are equivalents.  
Note 2) Structure and other details are subject to change without notice.

Features

- ① Energy-saving pump with a Top Runner efficiency (Equivalent to IE3) motor (VKC-e type).
- ② All-stainless parts are used in wetted parts.
- ③ It can be used with the liquid temperature -20°C to +90°C (No frozen liquid is allowed.).
- ④ A highly durable mechanical seal is adopted.
  - It is made of sic/porous sic, which is highly abrasion-resistant, with low adsorption, and a special structure.
- ⑤ EU RoHS Directive (RoHS 6 restricted substances) compliant.
- ⑥ It complies with EU directive (CE Marking).
- ⑦ Energy-saving operation with inverter (flow rate adjust, etc.) is possible (200 V class).
- ⑧ With the lineup of VKC-AH (pressure type) and VKC-AQ (flow rate type), a wide range of choices of head and flow rate is available.



Please note that the paint color, etc. of the actual unit may partially differ from the photo.

Description of types

**VKC 7 9 6 A H -e**

- ①
- ②
- ③
- ④
- ⑤
- ⑥
- ⑦

- ① Model
- ② Number of impellers
- ③ Number of casings
- ④ Series number
- ⑤ Phase                   A: 3-phase
- ⑥ Characteristics       H: Pressure type  
                                  Q: Flow rate type
- ⑦ Motor efficiency  
None: Standard efficiency (equivalent to IE1)  
-e : Top Runner efficiency (equivalent to IE3)

Usage

Chilled and hot water circulation system/washing equipment/feed water supply system/apparatus for adjusting mold temperature/lens smoothing and polishing machine/wet-blast device

Usable liquid

Fresh water, cleaning solvent, warm water, etc.

Standard Specification

Used liquid	Property of liquid	Grinding liquid, cutting liquid, etc. after secondary treatment *1		
	Temperature	-20 to 90 °C (No condensation)		
	Allowable kinematic viscosity	Type	Operation at 50 Hz	Operation at 60 Hz
VKC4□6AH-e, VKC7□6AH-e VKC4□6AQ-e		75mm <sup>2</sup> /s	37.5mm <sup>2</sup> /s	
Others		75mm <sup>2</sup> /s	75mm <sup>2</sup> /s	
Installation location		Indoor Ambient temperature: -20 to 40 °C, RH 85% or below (no condensation), Height above sea level : 1000m or less, Place not exposed to direct sunlight, Place in an area free of corrosive or explosive gas or vapor.		
Material	Pump legs	SCS14A		
	Casing	SUS304		
	Suction chamber	SCS14A		
	Impeller	SUS304		
	Main shaft (motor side+pump side)	S35C+SUS403		
Sealing structure		Mechanical seal		
Motor	Type	Totally enclosed fan-cooled indoor type		
	Protection method	IP54		
	Power source	3-phase 50/60/60Hz 200/200/220V		
	Thermal class	F		
	Number of poles	2P		
	Standard	IEC60034-1 CE Marking		
Paint color	Pump	Munsell N1		
	Motor	Black		

Special specification

Motor modifications	Voltage change, change of terminal box position, change of terminal box direction
---------------------	---

Table of Consumable Parts

Type	Bearing		Oil seal			O-ring (Companion flange) material: FKM
	Load side	Unload side	Load side (pump)	Load side (bearing)	Unload side	
VKC1□6AH(-e) ~ VKC4□6AH-e	6304ZZ C3	6203ZZ C3	DS17355	DS20325	DS20305	P32
VKC1□6AQ(-e) ~ VKC2□6AQ-e						
VKC5□6AH-e ~ VKC7□6AH-e	6306ZZ C3	6303ZZ C3				
VKC3□6AQ-e ~ VKC4□6AQ-e						

\*1 If the liquid contains hard sludge, such as abrasive powder, ground powder, or ground diamond grains, the service life might be shortened. Please set up a filter (magnet filter or paper filter, etc.). Take note that special liquid such as water, printing liquid or acid liquid cannot be used. Contact us for other special liquid (pure water, alkali-acid liquid, ceramic, etc.).

Selection chart

●VKC-AH/VKC-AH-e

(Values at kinematic viscosity 1mm<sup>2</sup>/s, specific gravity 1)  
 (Values at kinematic viscosity 75mm<sup>2</sup>/s, specific gravity 0.86)

Synchronous rotating speed 50Hz : 3000min<sup>-1</sup>  
 60Hz : 3600min<sup>-1</sup>

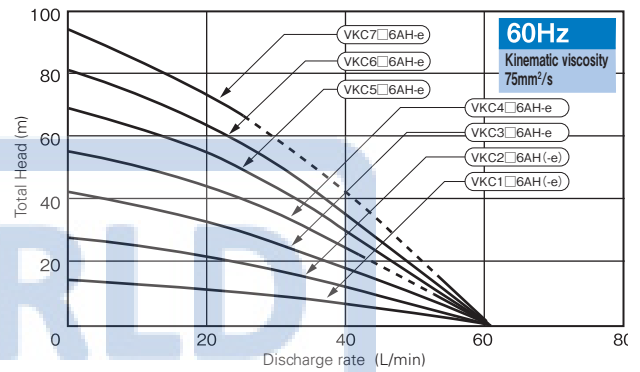
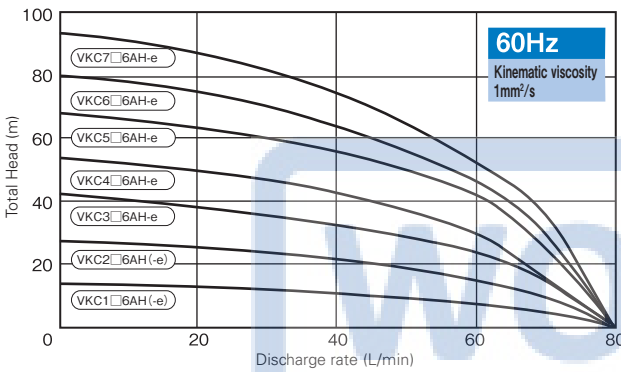
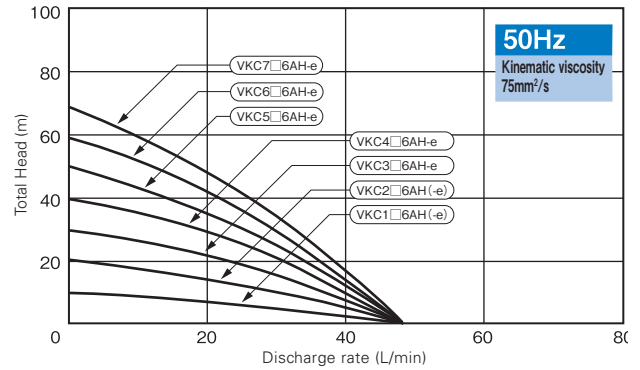
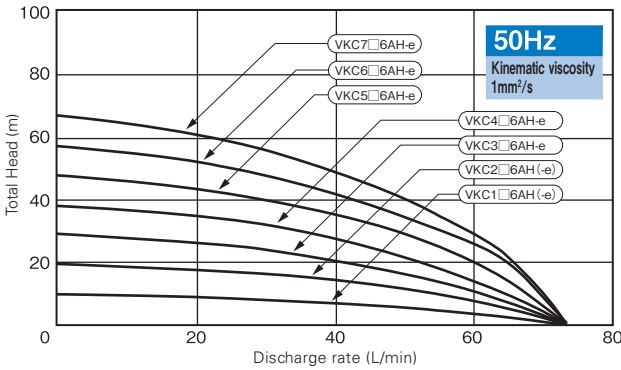

Note 1) Please note that discharge rate varies considerably depending on the type and kinematic viscosity of liquid.  
 Note 2) Please note that the dotted lines in the above diagrams show the range where it cannot be continuously operated at the oil viscosity of 75 mm<sup>2</sup>/s.  
 Note 3) The above chart may not be used depending on the kinematic viscosity and specific gravity of the liquid.

Specification table

●VKC-AH/VKC-AH-e

Type	50Hz							60Hz						
	Rated voltage (V)	Nominal output (kW)	Rated current (A)	Starting current (A)	Discharge rate (L/min)	Total head (m)	Allowable kinematic viscosity (mm <sup>2</sup> /s)	Rated voltage (V)	Nominal output (kW)	Rated current (A)	Starting current (A)	Discharge rate (L/min)	Total head (m)	Allowable kinematic viscosity (mm <sup>2</sup> /s)
VKC1□6AH	200	0.1	2.0	11	40	7	75	200/220	kW	1.9/1.9	9.0/10	50	9	75
VKC1□6AH-e	200	0.1	2.0	11.1	40	7		200/220	0.17	1.9/1.9	10.8/11.9	50	9	
VKC2□6AH	200	0.2	2.7	11	40	13		200/220	0.34	2.6/2.4	9.0/10	50	18	
VKC2□6AH-e	200	0.2	2.6	11.1	40	13		200/220	0.34	2.3/2.3	10.8/11.9	50	18	
VKC3□6AH-e	200	0.3	3.5	30	40	20		200/220	0.51	3.5/3.5	29/32	50	28	37.5
VKC4□6AH-e	200	0.4	4.0	30	40	27		200/220	0.68	4.0/4.0	29/32	50	37	
VKC5□6AH-e	200	0.5	5.5	56	40	33		200/220	0.85	5.6/5.4	55/60	50	46	75
VKC6□6AH-e	200	0.6	5.9	56	40	40		200/220	1.02	6.0/5.8	55/60	50	55	
VKC7□6AH-e	200	0.7	6.4	56	40	48		200/220	1.19	6.0/5.8	55/60	50	62	

Note 1) Discharge rate and total head are the values obtained in the tests with a liquid viscosity of 1mm<sup>2</sup>/s (same as fresh water at normal temperature).  
 Note 2) The pump's rated current (current value listed on the pump nameplate) is the recommended current setting for protection device.

Selection chart

●VKC-AQ/VKC-AQ-e

(Values at kinematic viscosity 1mm<sup>2</sup>/s, specific gravity 1)  
 (Values at kinematic viscosity 75mm<sup>2</sup>/s, specific gravity 0.86)

Synchronous rotating speed 50Hz : 3000min<sup>-1</sup>  
 60Hz : 3600min<sup>-1</sup>

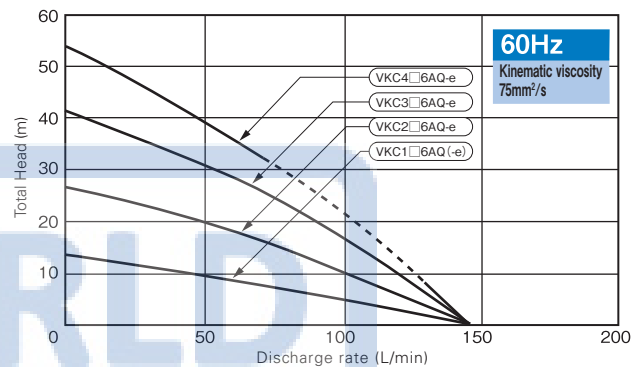
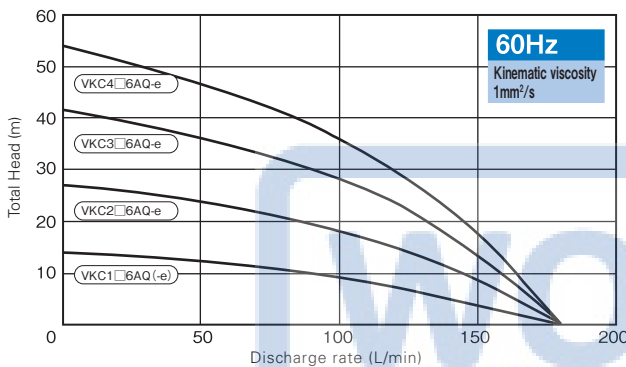
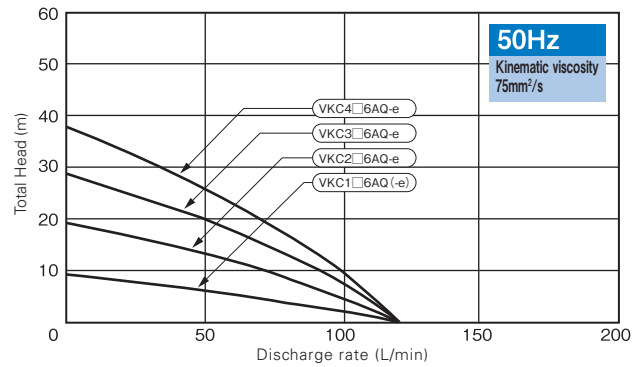
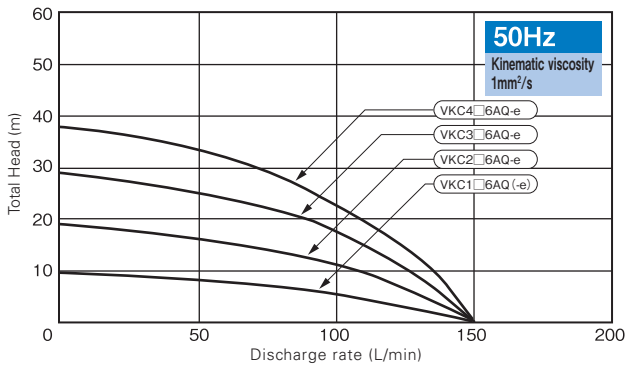

- Note 1) Please note that discharge rate varies considerably depending on the type and kinematic viscosity of liquid.
- Note 2) Please note that the dotted lines in the above diagrams show the range where it cannot be continuously operated at the kinematic of 75 mm<sup>2</sup>/s.
- Note 3) The above chart may not be used depending on the kinematic viscosity and specific gravity of the liquid.

Specification table

●VKC-AQ/VKC-AQ-e

Type	50Hz							60Hz						
	Rated voltage (V)	Nominal output (kW)	Rated current (A)	Starting current (A)	Discharge rate (L/min)	Total head (m)	Allowable kinematic viscosity (mm <sup>2</sup> /s)	Rated voltage (V)	Nominal output (kW)	Rated current (A)	Starting current (A)	Discharge rate (L/min)	Total head (m)	Allowable kinematic viscosity (mm <sup>2</sup> /s)
VKC1□6AQ	200	0.18	2.3	11	85	6	75	200/220	0.3	2.4/2.3	9.0/10	100	8	75
VKC1□6AQ-e	200	0.18	2.4	11.1	85	6		200/220	0.3	2.2/2.2	10.8/11.9	100	8	
VKC2□6AQ-e	200	0.36	3.6	30	85	13		200/220	0.6	4.0/4.0	29/32	100	18	
VKC3□6AQ-e	200	0.54	5.5	56	85	19		200/220	0.9	6.0/5.8	55/60	100	28	
VKC4□6AQ-e	200	0.72	6.4	56	85	26		200/220	1.2	6.0/5.8	55/60	100	36	37.5

- Note 1) Discharge rate and total head are the values obtained in the tests with a liquid viscosity of 1mm<sup>2</sup>/s (same as fresh water at normal temperature).
- Note 2) The pump's rated current (current value listed on the pump nameplate) is the recommended current setting for protection device.



Assembly drawing

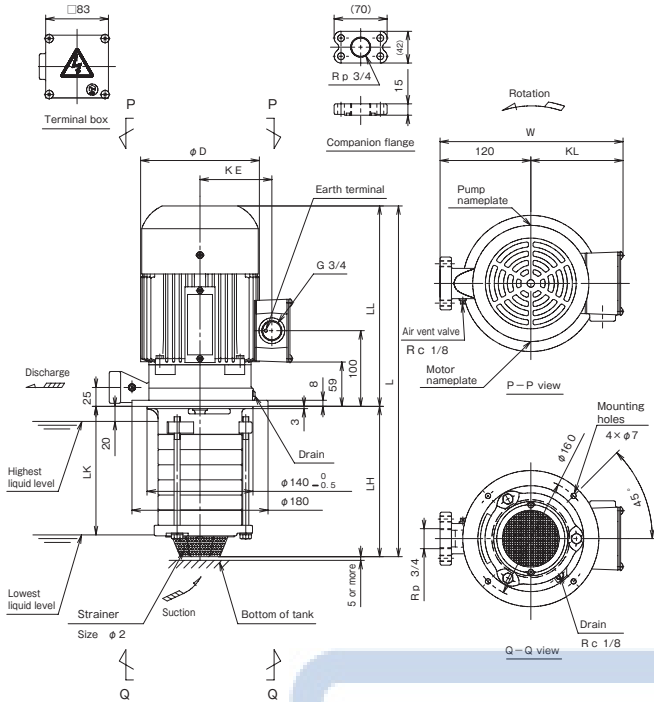

Dimensions

(Unit : mm)

Type	D	KE	KL	L	LH	LK	LL	W	Approx. mass(kg)
VKC136AH (-e)	140	88	115	384	139	110	245	235	15
VKC146AH (-e)	140	88	115	404	159	130	245	235	15
VKC156AH (-e)	140	88	115	424	179	150	245	235	15
VKC166AH (-e)	140	88	115	444	199	170	245	235	15
VKC236AH (-e)	140	88	115	384	139	110	245	235	15
VKC246AH (-e)	140	88	115	404	159	130	245	235	15
VKC256AH (-e)	140	88	115	424	179	150	245	235	15
VKC266AH (-e)	140	88	115	444	199	170	245	235	16
VKC276AH (-e)	140	88	115	464	219	190	245	235	16
VKC286AH (-e)	140	88	115	484	239	210	245	235	16
VKC296AH (-e)	140	88	115	504	259	230	245	235	16
VKC336AH-e	140	88	115	384	139	110	245	235	14
VKC346AH-e	140	88	115	404	159	130	245	235	14
VKC356AH-e	140	88	115	424	179	150	245	235	14
VKC366AH-e	140	88	115	444	199	170	245	235	15
VKC376AH-e	140	88	115	464	219	190	245	235	15
VKC386AH-e	140	88	115	484	239	210	245	235	15
VKC396AH-e	140	88	115	504	259	230	245	235	15
VKC446AH-e	140	88	115	404	159	130	245	235	14
VKC456AH-e	140	88	115	424	179	150	245	235	14
VKC466AH-e	140	88	115	444	199	170	245	235	15
VKC476AH-e	140	88	115	464	219	190	245	235	15
VKC486AH-e	140	88	115	484	239	210	245	235	15
VKC496AH-e	140	88	115	504	259	230	245	235	15
VKC556AH-e	157	95	122	444	179	150	265	242	19
VKC566AH-e	157	95	122	464	199	170	265	242	19
VKC576AH-e	157	95	122	484	219	190	265	242	19
VKC586AH-e	157	95	122	504	239	210	265	242	19
VKC596AH-e	157	95	122	524	259	230	265	242	20
VKC666AH-e	157	95	122	464	199	170	265	242	19
VKC676AH-e	157	95	122	484	219	190	265	242	19
VKC686AH-e	157	95	122	504	239	210	265	242	20
VKC696AH-e	157	95	122	524	259	230	265	242	20
VKC776AH-e	157	95	122	484	219	190	265	242	19
VKC786AH-e	157	95	122	504	239	210	265	242	20
VKC796AH-e	157	95	122	524	259	230	265	242	20
VKC126AQ (-e)	140	88	115	382	137	108	245	235	15
VKC136AQ (-e)	140	88	115	410	165	138	245	235	15
VKC146AQ (-e)	140	88	115	438	193	164	245	235	15
VKC156AQ (-e)	140	88	115	466	221	192	245	235	15
VKC166AQ (-e)	140	88	115	494	249	220	245	235	16
VKC226AQ-e	140	88	115	382	137	108	245	235	14
VKC236AQ-e	140	88	115	410	165	136	245	235	14
VKC246AQ-e	140	88	115	438	193	164	245	235	14
VKC256AQ-e	140	88	115	466	221	192	245	235	14
VKC266AQ-e	140	88	115	494	249	220	245	235	15
VKC336AQ-e	157	95	122	430	165	136	265	242	18
VKC346AQ-e	157	95	122	458	193	164	265	242	19
VKC356AQ-e	157	95	122	486	221	192	265	242	19
VKC366AQ-e	157	95	122	514	249	220	265	242	19
VKC446AQ-e	157	95	122	458	193	164	265	242	19
VKC456AQ-e	157	95	122	486	221	192	265	242	19
VKC466AQ-e	157	95	122	514	249	220	265	242	19

Detailed drawing of the terminal box

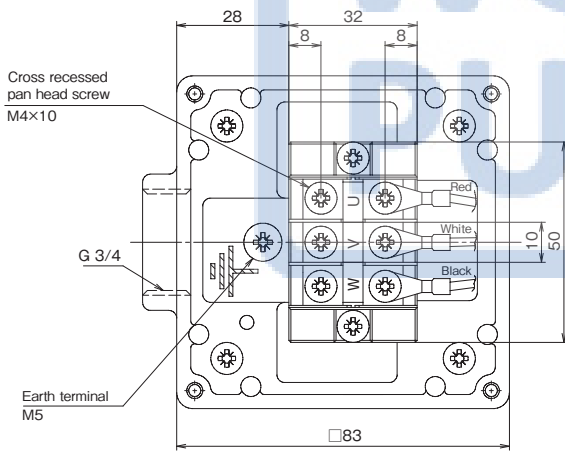

Sectional drawing

●VKC-AH/VKC-AH-e

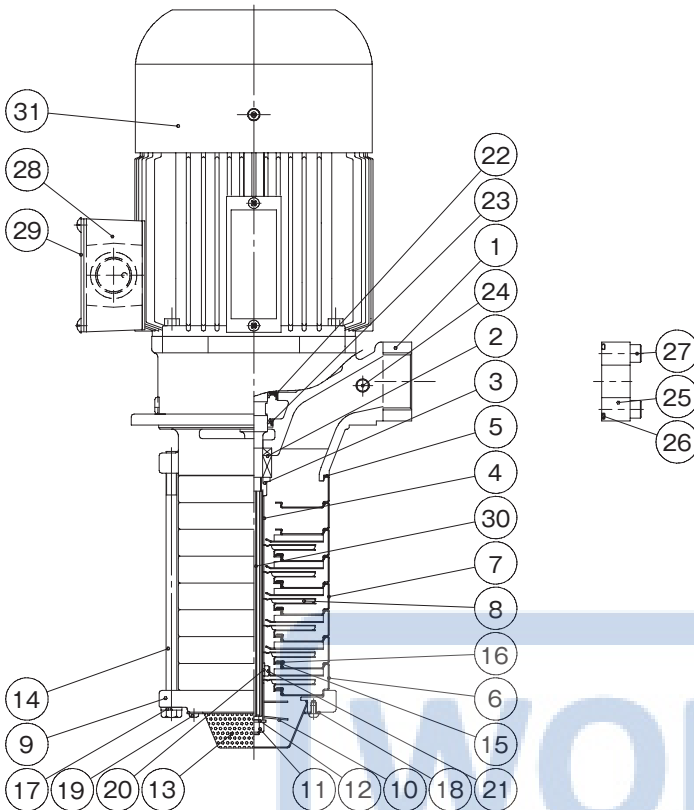

No.	Part name	Material
1	Pump leg	SCS14A
2	Mechanical seal	SIC/SIC
3	Washer	SUS304
4	Collar	SUS304
5	Teflon packing	PTFE
6	Casing (without guide vane)	SUS304
7	Casing (with guide vane)	SUS304
8	Impeller	SUS304
9	Suction chamber	SCS14A
10	Screw	SUS304
11	U-nut	SUS304
12	Washer	SUS304
13	Wide strainer	SUS304
14	Fastening bolt	SUS304
15	Seal ring	PTFE
16	Hold metal	SUS304
17	Spring washer	SUS304
18	Strainer holding metal	SUS304
19	Cross recessed pan head screw	SUS304
20	Sleeve *	WC
21	Bearing ring *	Ceramic
22	Oil seal	NBR
23	Oil seal	NBR
24	Air vent valve	SUS304
25	Companion flange	SCS16A
26	O-ring	FKM
27	Hex socket head bolt	SUS304
28	Terminal box	ADC
29	Lid of terminal box	SS400
30	Main shaft (motor side + pump side)	S35C+SUS403
31	Motor	—

\* Not used in pumps with 6 or fewer stages.

Note 1) The materials in the table above are equivalents.

Note 2) Structure and other details are subject to change without notice.

●VKC-AQ/VKC-AQ-e

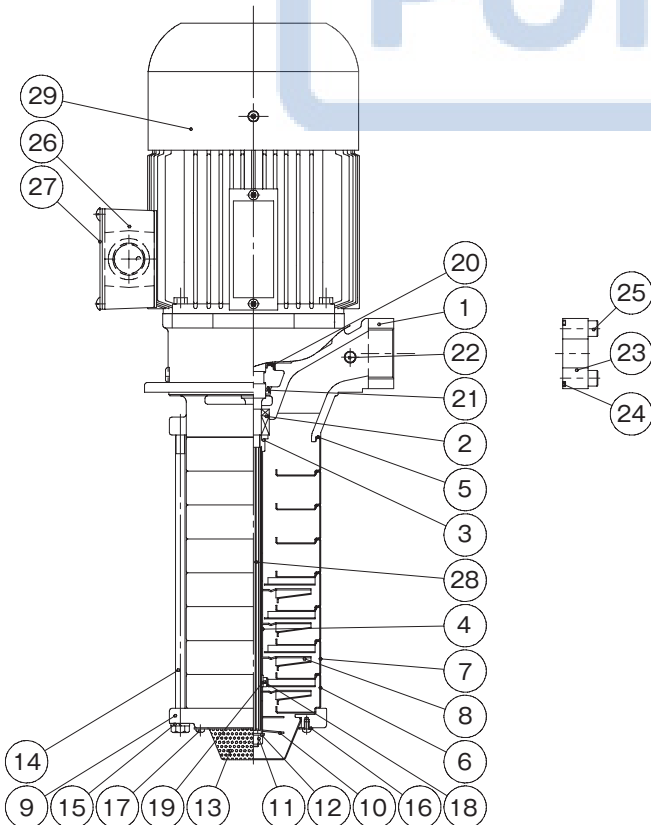

No.	Part name	Material
1	Pump leg	SCS14A
2	Mechanical seal	SIC/SIC
3	Washer	SUS304
4	Collar	SUS304
5	Teflon packing	PTFE
6	Casing (without guide vane)	SUS304
7	Casing (with guide vane)	SUS304
8	Impeller	SUS304
9	Suction chamber	SCS14A
10	Screw	SUS304
11	U-nut	SUS304
12	Washer	SUS304
13	Wide strainer	SUS304
14	Fastening bolt	SUS304
15	Spring washer	SUS304
16	Strainer holding metal	SUS304
17	Cross recessed pan head screw	SUS304
18	Bearing ring *	Ceramic
19	Sleeve *	WC
20	Oil seal	NBR
21	Oil seal	NBR
22	Air vent valve	SUS304
23	Companion flange	SCS16A
24	O-ring	FKM
25	Hex socket head bolt	SUS304
26	Terminal box	ADC
27	Lid of terminal box	SS400
28	Main shaft (motor side + pump side)	S35C+SUS403
29	Motor	—

\* Not used in pumps with 5 or fewer stages.

Note 1) The materials in the table above are equivalents.

Note 2) Structure and other details are subject to change without notice.

### Features

- ① An energy-saving pump with a Top Runner efficiency (equivalent to IE3) motor.
- ② Strong and tough enough to resist dirty coolants.
- ③ The impeller is made of FCD and is highly durable.
- ④ Long and short types of immersion depth are available to suit various tank depths.
- ⑤ Can be used for highly viscous coolants (LFO□□B-e model).
- ⑥ High resistance due to non-seal (mechanical seal-less) structure.
- ⑦ Mounting dimensions are compatible with conventional pumps.

### Description of types

#### LFO 50 A - 0.75 - 35 -e

① ② ③ ④ ⑤ ⑥

- ① Model
- ② Bore diameter
- ③ Viscosity of the liquid A : for low viscosity liquid B : for high viscosity liquid
- ④ Output
- ⑤ Immersion depth 35:350mm 50:500mm
- ⑥ Motor efficiency Top Runner efficiency (equivalent to IE3)



Please note that the paint color, etc. of the actual unit may partially differ from the photo.

### Standard Specification

Used liquid	Property of liquid	Liquids containing additives (anticorrosive, etc.), for water-soluble and water-insoluble coolants*	
	Temperature	0 to 40°C (No frozen liquid)	
	Allowable kinematic viscosity	LFO-A : 32mm <sup>2</sup> /s LFO-B : 150mm <sup>2</sup> /s	
Installation location		Indoor Ambient temperature: 0 to 40 °C, RH 85% or below (no condensation), Height above sea level : 1000m or less, Place not exposed to direct sunlight, Place in an area free of corrosive or explosive gas or vapor.	
Material	Casing	FC200	
	Discharge pipe	SGP + SS	
	Impeller	FCD450	
	Main shaft	2.2 kW or less : S35C 3.7 kW or more : S45C	
Sealing structure		Non-seal (mechanical seal-less)	
Motor	Power source	3-phase 50/60/60Hz 200/200/220V	0.75~2.2kW
		3-phase 50/60/60Hz 200/200/220V	3.7~5.5kW
		3-phase 50/60/60Hz 400/400/440V	
	Type	Totally enclosed fan-cooled indoor type	
	Protection method	IP44	
	Thermal class	F	
Rating		Continuous	
Number of poles		2P	
Paint color		Munsell N1.5	

\*Do not use with freshwater.

### Table of Consumable Parts

Output (kW)	Bore diameter (mm)	Bearing		Oil seal	O-ring (for discharge pipes)
		Load side	Unload side		
0.75	50	6205ZXC3	6203ZXC3	G25355	G60
1.5	50	6306ZXC3	6303ZXC3	G30456	
	65				
2.2	65	6306ZXC3	6303ZXC3	G30456	G75
	80				G90
3.7	65	6208ZXC3	6205ZXC3	VC40586	G75
	80				G90
5.5	80	6210ZXC3	6206ZXC3	VC50687	G90

### Selection chart

● For low viscosity liquid (Values at kinematic viscosity 1mm<sup>2</sup>/s, specific gravity 1)

#### 50Hz

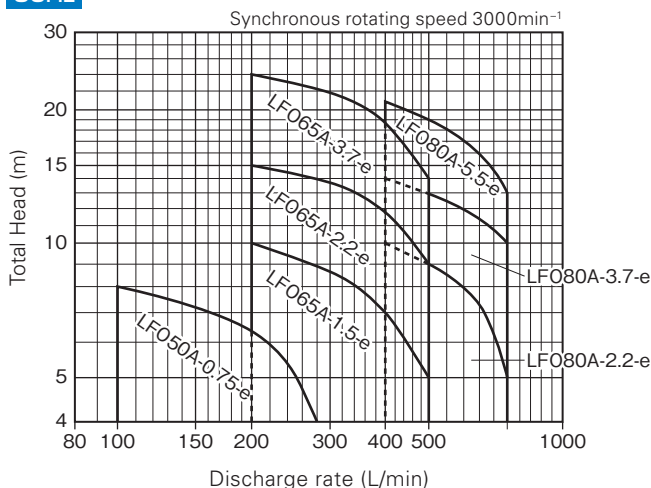

#### 60Hz

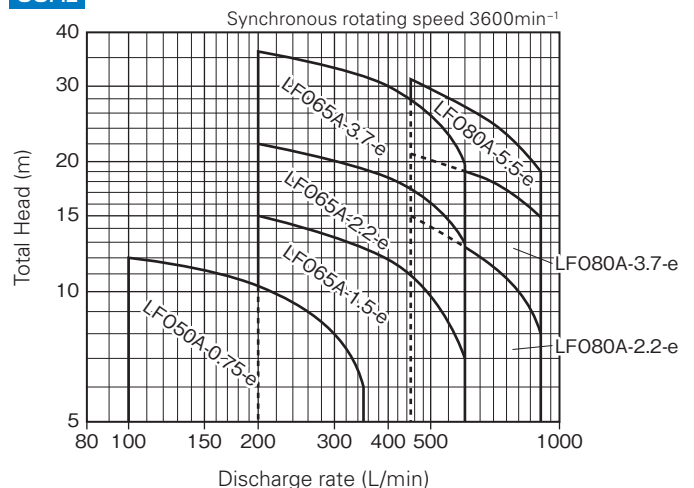

\*The above chart may not be used depending on the kinematic viscosity and specific gravity of the liquid.  
\*Use pumps within the selection range. Do not operate with flow rate below the selection range.

Specification table

For low viscosity liquid

Bore diameter (mm)	Frequency (Hz)	Type	Rated voltage (V)	Output (kW)	Rated current (A)	Starting current (A)	Discharge rate (L/min)	Total head (m)	
50	50	LFO50A-0.75-35(50)-e	200	0.75	4.0	30	100~280	8~4	
65		LFO65A-1.5-35(50)-e		1.5	6.5	66		10~5	
		LFO65A-2.2-35(50)-e		2.2	9.3	84			
80		LFO65A-3.7-35(50)-e	200/400	3.7	14.7	134	200~500	15~9	
		LFO80A-2.2-35(50)-e	200	2.2	9.3	84		10~5	
		LFO80A-3.7-35(50)-e		3.7	14.7	134			14~10
80	LFO80A-5.5-35(50)-e	200/400	5.5	22.9	155	400~750	21~13		
	50	LFO50A-0.75-35(50)-e	200/220	0.75	3.5/3.5		29/32	100~350	12~6
		LFO65A-1.5-35(50)-e		1.5	6.3/5.8		64/70		15~7
65	LFO65A-2.2-35(50)-e	2.2		8.4/7.9	73/80	22~13			
	80	LFO65A-3.7-35(50)-e	200/220 400/440	3.7	13.7/12.9		116/130	200~600	36~20
LFO80A-2.2-35(50)-e		200/220	2.2	8.4/7.9	73/80	15~8			
LFO80A-3.7-35(50)-e		200/220 400/440	3.7	13.7/12.9	116/130		450~900		21~15
80	LFO80A-5.5-35(50)-e	400/440	5.5	20.9/19.6	128/144	31~19			

Note 1) The pump's rated current (current value listed on the pump nameplate) is the recommended current setting for protection device.

Selection chart

For high-viscosity liquid (Value at 150 mm<sup>2</sup>/s kinematic viscosity, specific gravity 1)

50Hz

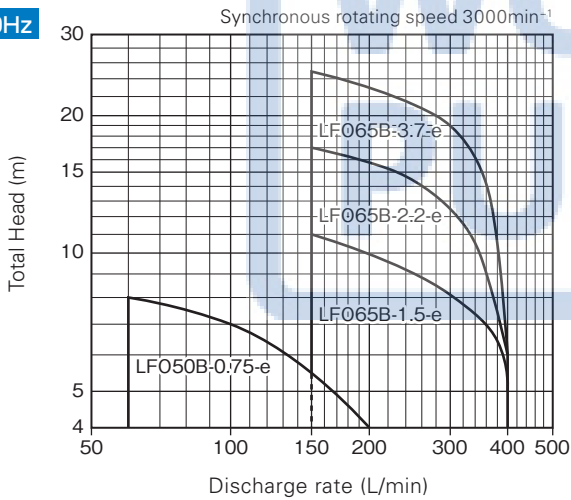

60Hz

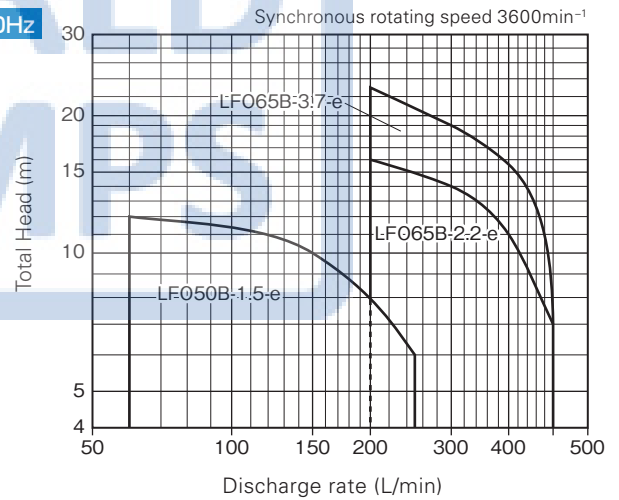

※Use pumps within the selection range. Do not operate with flow rate below the selection range.

Specification table

For high-viscosity liquid

Bore diameter (mm)	Frequency (Hz)	Type	Rated voltage (V)	Output (kW)	Rated current (A)	Starting current (A)	Discharge rate (L/min)	Total head (m)
50	50	LFO50B-0.75-35(50)-e	200	0.75	4.0	30	60~200	8~4
65		LFO65B-1.5-35(50)-e		1.5	6.5	66		11~5
		LFO65B-2.2-35(50)-e		2.2	9.3	84		
65		LFO65B-3.7-35(50)-e	200/400	3.7	14.7	128/144	25~6	
50	60	LFO50B-1.5-35(50)-e	200/220	1.5	6.3/5.8	64/70	60~250	12~6
65		LFO65B-2.2-35(50)-e		2.2	8.4/7.9	73/80		16~7
		LFO65B-3.7-35(50)-e	200/220 400/440	3.7	13.7/12.9	128/144	200~500	

Note 1) The pump's rated current (current value listed on the pump nameplate) is the recommended current setting for protection device.

Assembly drawing

Note 1) 3.7/5.5 kW motor wiring holes are shown in Figure 2  
 Note 2) For 80 mm bore diameter, the outlet is a square flange (to be screwed-in) as shown in Figure 3

Fig.1

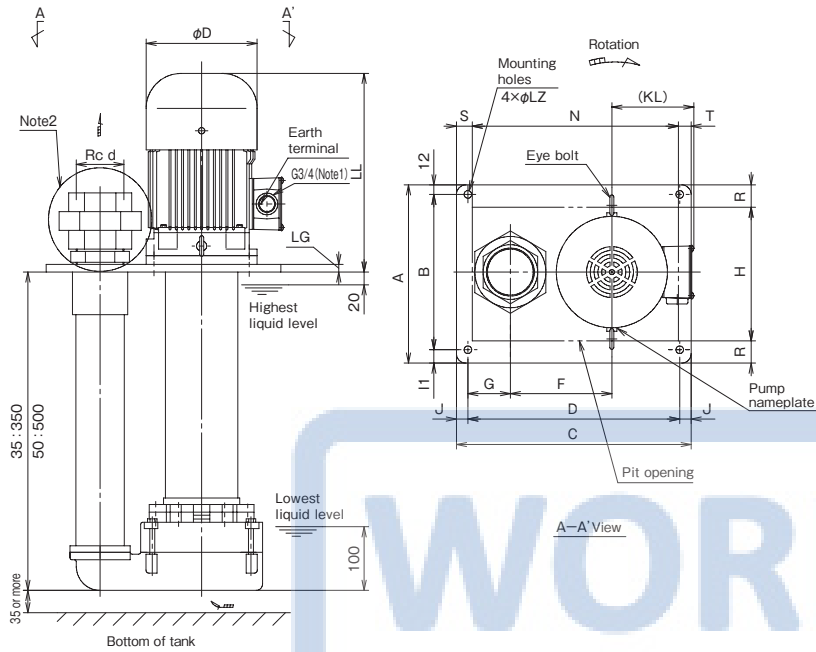

Fig.2

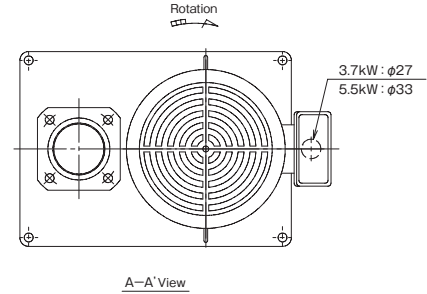
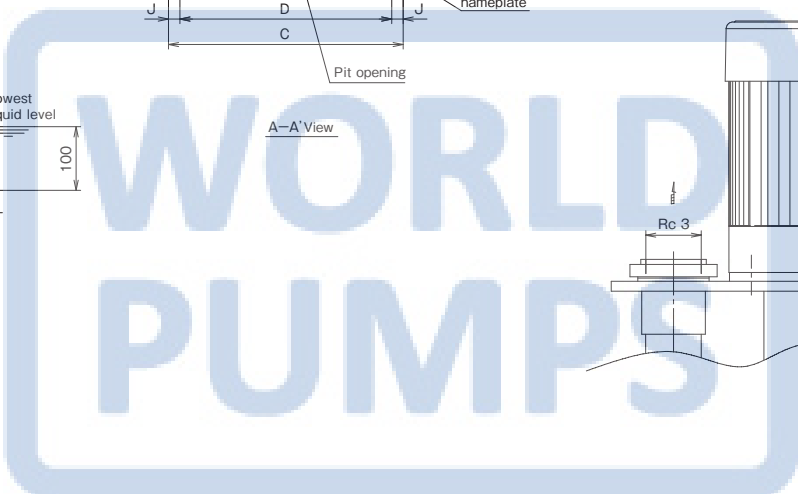
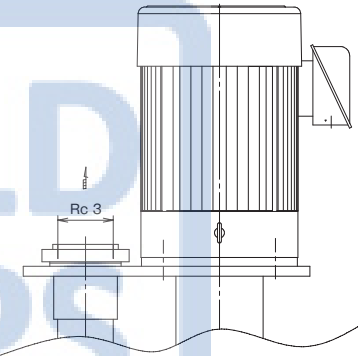

Fig.3



Dimensions

(Unit : mm)

Viscosity	Bore diameter (mm)	Type	d	A	B	C	D	F	G	H	I1	I2	J	LG	LL	KL	N	D	LZ	R	S	T	Approx. mass(kg)	
For low viscosity	50	LFO50A-0.75-35	-e	2	260	224	300	264	145	37	170	18	18	18	12	252	115	270	140	12	45	10	20	34
		LFO50A-0.75-50	-e	2	260	224	300	264	145	37	170	18	18	18	12	252	115	270	140	12	45	10	20	35
		LFO65A-1.5-35	-e	2 1/2	280	244	370	334	160	67	210	21	15	18	12	312	130	315	175	12	35	15	40	50
	65	LFO65A-2.2-35	-e	2 1/2	310	280	420	390	180	85	250	15	15	15	12	312	130	360	175	15	30	30	30	52
		LFO65A-2.2-50	-e	2 1/2	310	280	420	390	180	85	250	15	15	15	12	312	130	360	175	15	30	30	30	56
		LFO65A-3.7-35	-e	2 1/2	310	280	420	390	180	85	250	15	15	15	12	363	171	360	235	15	30	30	30	81
	80	LFO80A-2.2-35	-e	3	310	280	430	400	190	85	250	15	15	15	12	312	130	370	175	15	30	30	30	83
		LFO80A-2.2-50	-e	3	310	280	430	400	190	85	250	15	15	15	12	312	130	370	175	15	30	30	30	56
		LFO80A-3.7-35	-e	3	310	280	430	400	190	85	250	15	15	15	12	363	171	370	235	15	30	30	30	58
For high viscosity	50	LFO80A-5.5-35	-e	3	330	300	460	430	215	85	270	15	15	15	16	434	212	400	264	15	30	30	30	82
		LFO50B-0.75-35	-e	2	260	224	300	264	145	37	170	18	18	18	12	252	115	270	140	12	45	10	20	84
		LFO50B-0.75-50	-e	2	260	224	300	264	145	37	170	18	18	18	12	252	115	270	140	12	45	10	20	109
	65	LFO50B-1.5-35	-e	2	260	224	300	264	145	37	170	18	18	18	12	312	130	270	175	12	45	10	22	112
		LFO50B-1.5-50	-e	2	260	224	300	264	145	37	170	18	18	18	12	312	130	270	175	12	45	10	22	34
		LFO65B-1.5-35	-e	2 1/2	280	244	370	334	160	67	210	21	15	18	12	312	130	315	175	12	35	15	40	40
	80	LFO65B-2.2-35	-e	2 1/2	310	280	420	390	180	85	250	15	15	15	12	312	130	360	175	15	30	30	30	50
		LFO65B-2.2-50	-e	2 1/2	310	280	420	390	180	85	250	15	15	15	12	312	130	360	175	15	30	30	30	52
		LFO65B-3.7-35	-e	2 1/2	310	280	420	390	180	85	250	15	15	15	12	363	171	360	235	15	30	30	30	56
80	LFO65B-3.7-50	-e	2 1/2	310	280	420	390	180	85	250	15	15	15	12	363	171	360	235	15	30	30	30	58	
	LFO65B-3.7-50	-e	2 1/2	310	280	420	390	180	85	250	15	15	15	12	363	171	360	235	15	30	30	30	81	
	LFO65B-3.7-50	-e	2 1/2	310	280	420	390	180	85	250	15	15	15	12	363	171	360	235	15	30	30	30	83	

Detailed drawing of the terminal box

● Output 2.2 kW or less

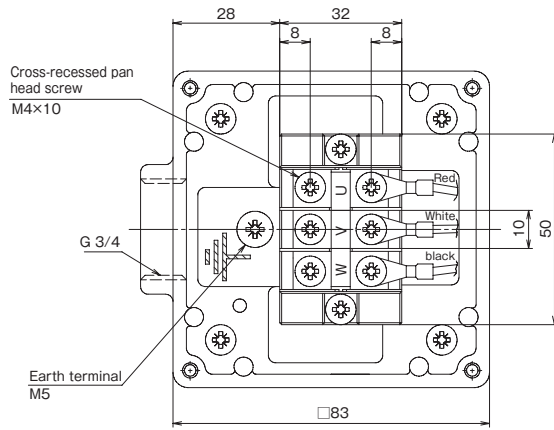

● Output 3.7 kW or more

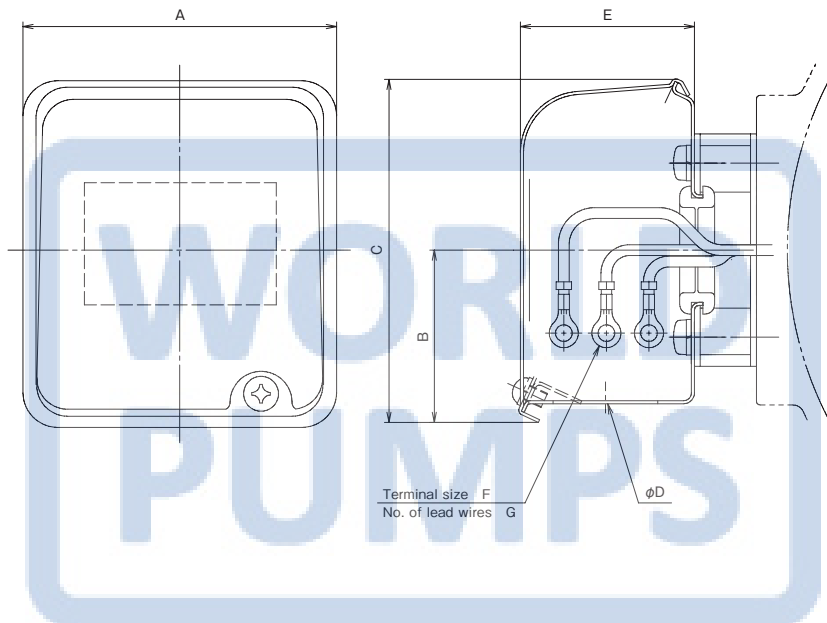

Terminal box

Output (kW)	A	B	C	D	E	F	G
3.7	82	45	89	27	46	1.25-4	9
5.5	126	68	133	33	60	2-5	12

Connection diagram

● Output 3.7 kW

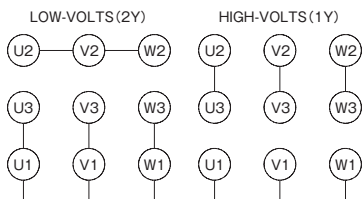

● Output 5.5 kW

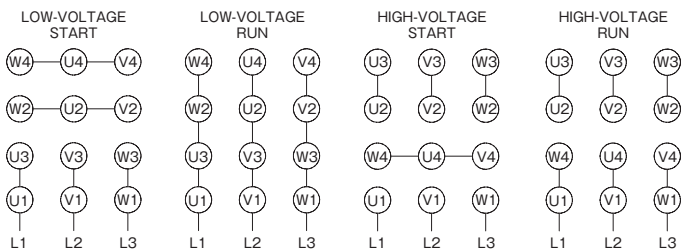

Sectional drawing

●LFO50-e, LFO65-e

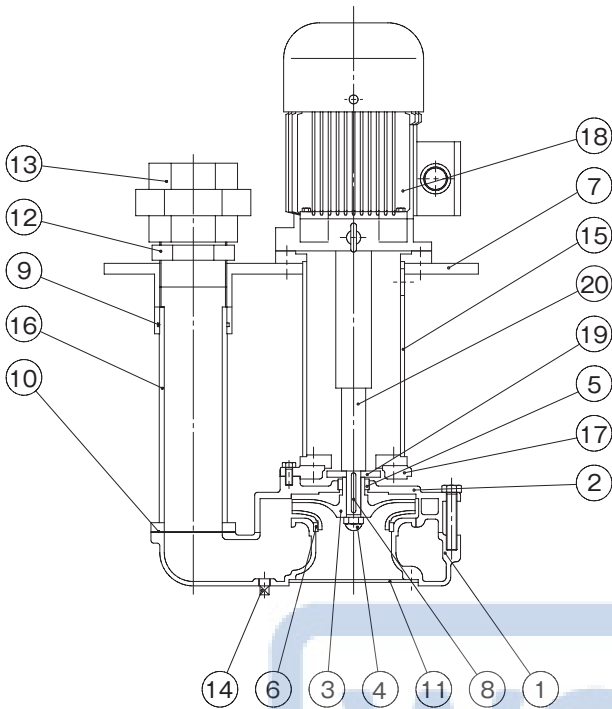

No.	Part name	Qty	Material
1	Casing	1	FC200
2	Casing cover	1	FC200
3	Impeller	1	FCD450
4	Impeller nut	1	SUS304
5	Discharge bushing	1	SUS304
6	Liner ring	1	SUS304
7	Common bed	1	SS400
8	Key	1	S35C
9	O-ring	1	NBR
10	Sheet packing	1	Three sheet
11	Strainer	1	SS400
12	Nipple	1	FC
13	Union	1	FC
14	Plug	1	SS400
15	Protection pipe	1	SGP + SS
16	Discharge pipe	1	SGP + SS
17	Connection flange	1	FC200
18	Motor	1	
19	Deflector	1	SS400
20	Main shaft	1	S35C(2.2kW or less)/ S45C(3.7kW or more)

Note 1) The materials in the table above are equivalents.  
Note 2) Structure and other details are subject to change without notice.

●LFO80-e

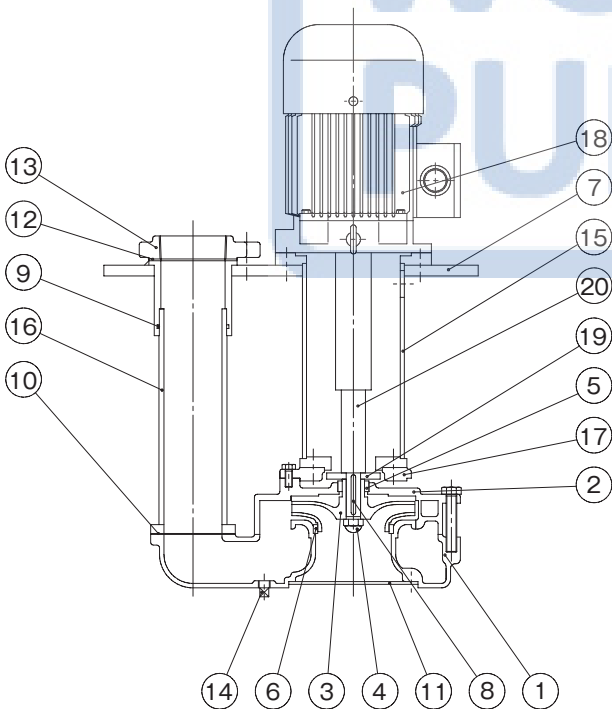

No.	Part name	Qty	Material
1	Casing	1	FC200
2	Casing cover	1	FC200
3	Impeller	1	FCD450
4	Impeller nut	1	SUS304
5	Discharge bushing	1	SUS304
6	Liner ring	1	SUS304
7	Common bed	1	SS400
8	Key	1	S35C
9	O-ring	1	NBR
10	Sheet packing	1	Three sheet
11	Strainer	1	SS400
12	Sheet packing	1	Three sheet
13	Companion flange	1	FC200
14	Plug	1	SS400
15	Protection pipe	1	SGP + SS
16	Discharge pipe	1	SGP + SS
17	Connection flange	1	FC200
18	Motor	1	
19	Deflector	1	SS400
20	Main shaft	1	S35C(2.2kW or less)/ S45C(3.7kW or more)

Note 1) The materials in the table above are equivalents.  
Note 2) Structure and other details are subject to change without notice.

**Features**

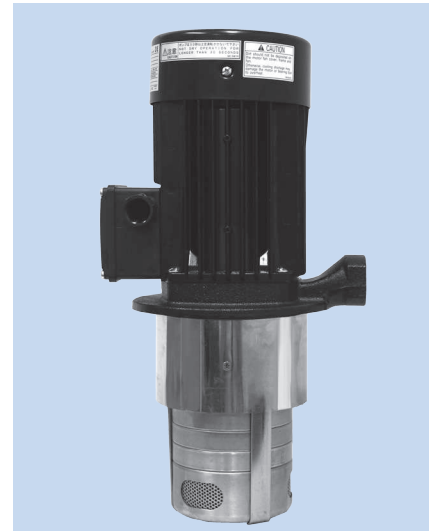

Please note that the paint color, etc. of the actual unit may partially differ from the photo.

- ① With a non-seal (mechanical seal-less) structure, it is easy to maintain.
- ② A motor is highly compact and light weight!! (Compared with our product: height of the motor is reduced by 20 mm).
- ③ The lineup included the models complying with international standards by supporting efficiency and other regulations.
  - Japan : Top Runner efficiency
  - Europe : IE3 efficiency, CE marking (EU Directive)  
EU RoHS (RoHS 6 restricted substances)
  - United States: NEMA Premium efficiency (IE3 efficiency), UL standards\*  
※ Please contact us for further specifications.
  - South Korea : KC standard (efficiency)
  - Canada : CSA standard (efficiency), CSA standard (safety)  
※ Please contact us for further specifications.
- ④ These are energy saving pumps with high efficiency impellers and IE3 efficiency motors.
- ⑤ Highly abrasion-resistant SiC bearings are adopted in the pump bearings.
- ⑥ Measures against air suction into the pump are taken when the liquid level lowers.
- ⑦ Capable of energy-saving operation with an inverter (flow rate adjustment etc.).

**Non-seal structure**

TERAL's original "non-seal" structure allows coolant to flow from a narrow clearance without using a seal between the pump section and the motor section.

**The advantages of a non-seal pump**

- 1 No trouble such as coolant leaks.**  
Helps cut down on running costs.
- 2 Prevents air entrainment.**  
Reduces initial problems.
- 3 Not easily affected by a small quantity of liquid or shut-off operations.**  
Enables a flexible operation system.

**※What is non-seal structure?**

This structure inwardly releases coolant by depressurizing through a narrow clearance without the use of a mechanical seal.

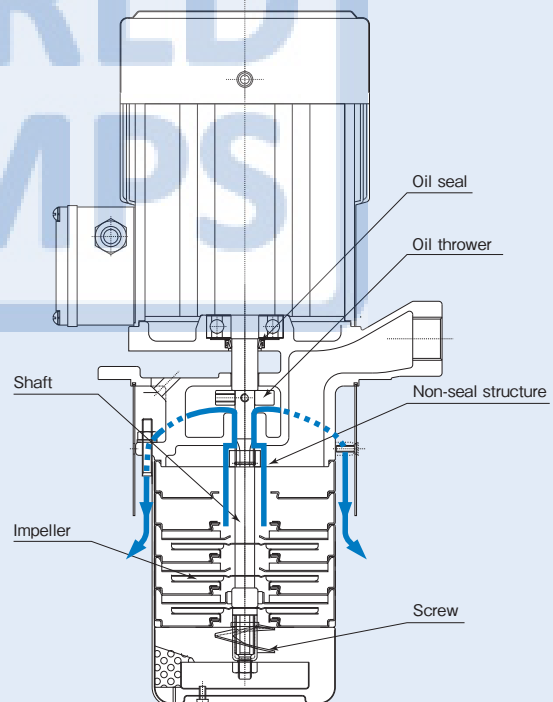



**Description of types**

**LBK 2 - 60 / 3 -F -e**

① ② ③ ④ ⑤ ⑥

- ① Model
- ② Nominal flow rate [m<sup>3</sup>/h]
- ③ Number of casings×10
- ④ Number of impellers
- ⑤ ID code H: available for high viscous liquid (models with 8 impellers only)  
(\*Other models than the above can be used for high viscous liquid as standard.)  
F: exclusive for 50Hz
- ⑥ Motor efficiency Top Runner efficiency (equivalent to IE3)

**Standard Specification**

Used liquid	Property of liquid	Grinding liquid, cutting liquid, etc. after secondary treatment *1
	Temperature	-10 to 90 °C (no frozen liquid)
Allowable kinematic viscosity *2		75mm <sup>2</sup> /S
Installation location		Indoor Ambient temperature: -20 to 40 °C, RH 85% or below (no condensation), Height above sea level : 1000m or less, Place not exposed to direct sunlight, Place in an area free of corrosive or explosive gas or vapor.
Material	Discharge casing	FC200
	Casing Outer sleeve	SUS304
	Suction casing	SUS304
	Impeller	SUS304
	Main shaft (motor side+pump side)	S45C+SUS431
Sealing structure		Non-seal (mechanical seal-less)
Motor	Type	Totally enclosed fan-cooled indoor type
	Protection method	IP54
	Power source	3-phase 50/60/60Hz 200/200/230V
	Thermal class	F
	Number of poles	2P
Paint color	Pump	Munsell N1
	Motor	Black

※1 If the liquid contains hard sludge, such as abrasive powder, ground powder, or ground diamond grains, the service life might be shortened. Please set up a filter (magnet filter or paper filter, etc.). Take note that special liquid such as water, printing liquid or acid liquid cannot be used. Contact us for other special liquid (pure water, alkali-acid liquid, ceramic, etc.).

※2 Allowable kinematic viscosity for LBK2-□/8-e is 1mm<sup>2</sup>/s.

**Special specification**

Motor modifications	Change of terminal box position
---------------------	---------------------------------

**Table of Consumable Parts**

Frequency Hz	Output kW	Bearing		Oil seal
		Load side	Unload side	Pump part
50/60	0.35/0.55	6303ZZC3	6201ZZC3	IS12257
50/60	0.55/0.75			
50/60	0.8/1.1			
50	1.1	6205ZZC3	6304ZZC3	
50/60	1.2/1.5			
50/60	1.8/2.2			

**Selection chart**

(Values at kinematic viscosity 1mm<sup>2</sup>/s, specific gravity 1)

● **Pressure type LBK2**

**50Hz**

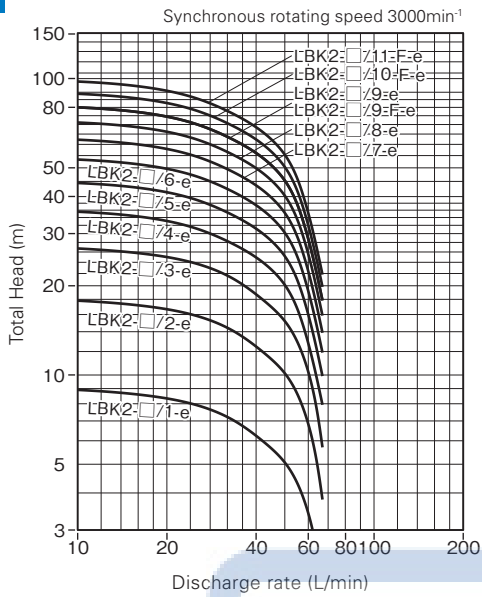

**60Hz**

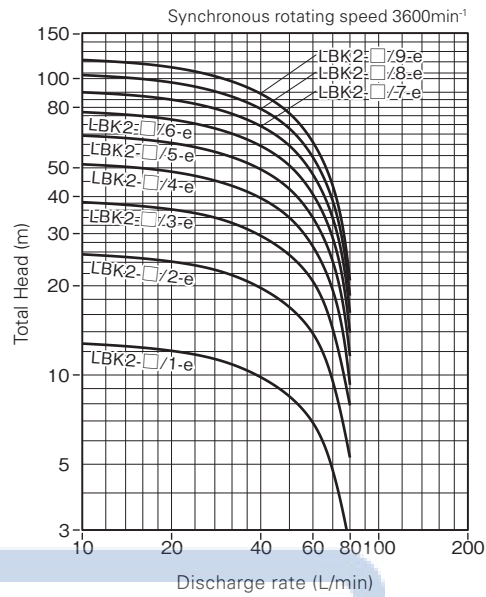

● **Flow rate type LBK4**

**50Hz**

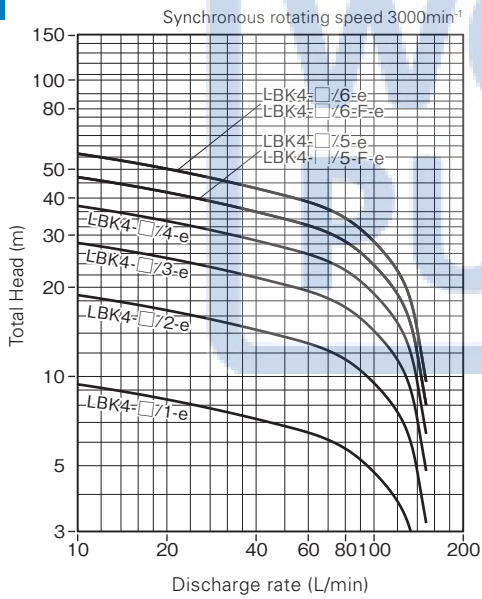

**60Hz**

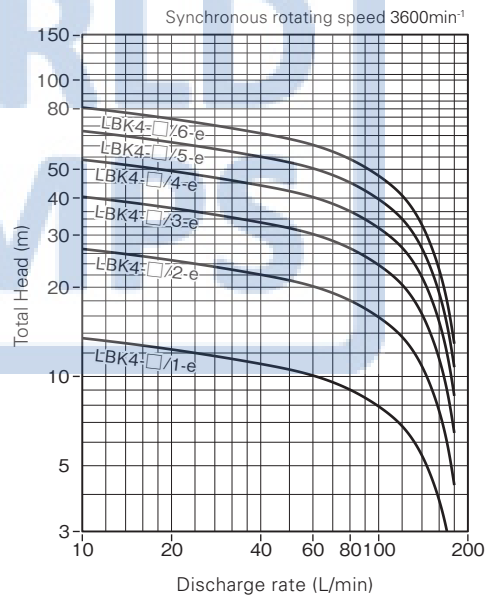

※ The specified flow may not be achieved in the large water volume range depending on the discharge pipe diameter.

**Selection chart**

(Values at kinematic viscosity 75mm<sup>2</sup>/s, specific gravity 0.86)

● **Pressure type LBK2**

**50Hz**

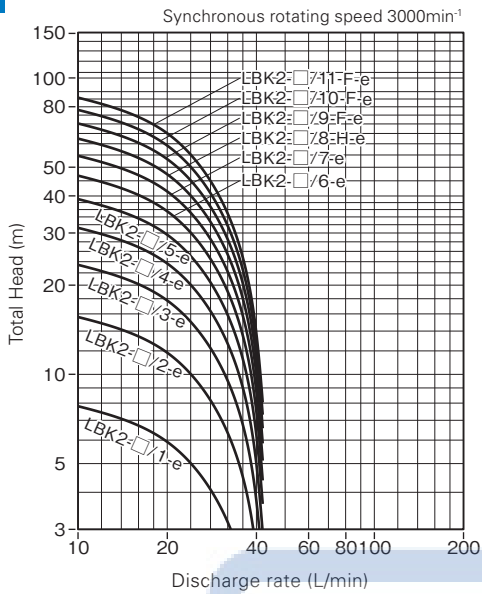

**60Hz**

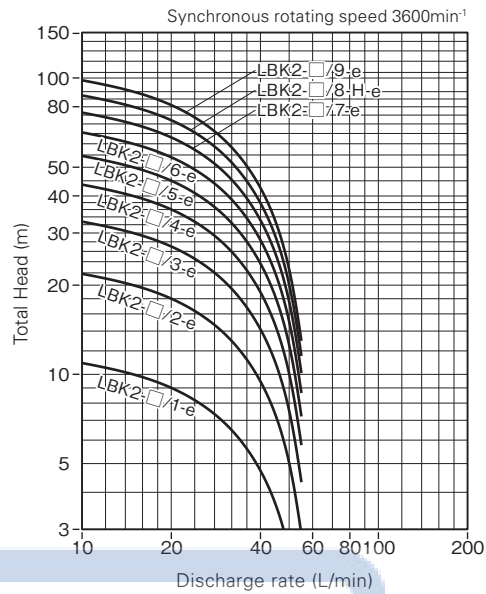

● **Flow rate type LBK4**

**50Hz**

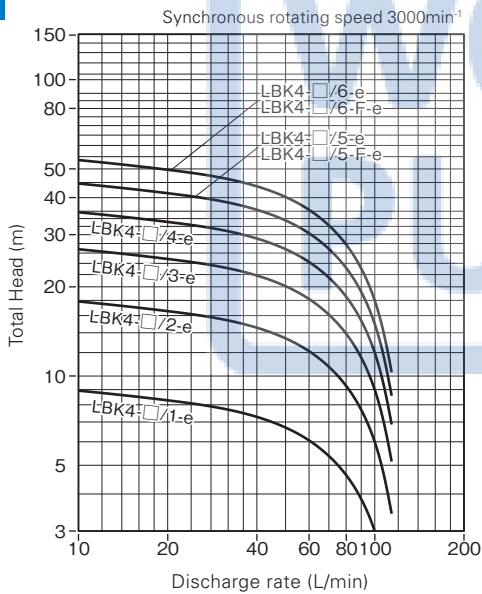

**60Hz**

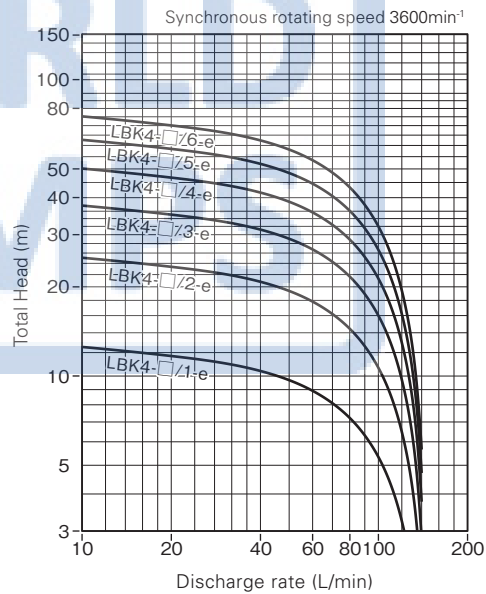

※ The specified flow may not be achieved in the large water volume range depending on the discharge pipe diameter.

Specification table

Type	50Hz						60Hz					
	Rated voltage (V)	Output (kW)	Rated current (A)	Starting current (A)	Discharge rate (L/min)	Total head (m)	Rated voltage (V)	Output (kW)	Rated current (A)	Starting current (A)	Discharge rate (L/min)	Total head (m)
LBK2-□/1-e	200	0.35	3.5	16.4	42	6	200/230	0.55	3.5/3.5	15.5/17.9	50	8.4
LBK2-□/2-e	200	0.35	3.5	16.4	42	12	200/230	0.55	3.5/3.5	15.5/17.9	50	16.9
LBK2-□/3-e	200	0.35	3.5	16.4	42	18	200/230	0.55	3.5/3.5	15.5/17.9	50	25.4
LBK2-□/4-e	200	0.55	3.9	26	42	24	200/230	0.75	4.1/4.1	25/27	50	33.9
LBK2-□/5-e	200	0.55	3.9	26	42	30	200/230	0.75	4.1/4.1	25/27	50	42.4
LBK2-□/6-e	200	0.8	6.3	40	42	36	200/230	1.1	6.0/6.0	38.8/42.9	50	50.9
LBK2-□/7-e	200	0.8	6.3	40	42	42	200/230	1.1	6.0/6.0	38.8/42.9	50	59.3
LBK2-□/8-e	200	0.8	6.3	40	25	62.5	200/230	1.1	6.0/6.0	38.8/42.9	30	88.9
LBK2-□/8-H-e	200	1.2	6.2	47	42	48	200/230	1.5	7.8/7.0	41.0/47.6	50	67.8
LBK2-□/9-e	200	1.2	6.2	47	42	54	200/230	1.5	7.8/7.0	41.0/47.6	50	76.3
LBK2-□/9-F-e	200	1.1	6.2	35	42	54	-	-	-	-	-	-
LBK2-□/10-F-e	200	1.1	6.2	35	42	60	-	-	-	-	-	-
LBK2-□/11-F-e	200	1.1	6.2	35	42	66	-	-	-	-	-	-
LBK4-□/1-e	200	0.35	3.5	16.4	85	5.5	200/230	0.55	3.5/3.5	15.5/17.9	100	7.9
LBK4-□/2-e	200	0.35	3.5	16.4	85	11	200/230	0.55	3.5/3.5	15.5/17.9	100	15.9
LBK4-□/3-e	200	0.55	3.9	26	85	16.5	200/230	0.75	4.1/4.1	25/27	100	23.8
LBK4-□/4-e	200	0.8	6.3	40	85	21.9	200/230	1.1	6.0/6.0	38.8/42.9	100	31.7
LBK4-□/5-e	200	1.2	6.2	47	85	27.4	200/230	1.5	7.8/7.0	41.0/47.6	100	39.6
LBK4-□/6-e	200	1.8	7.4	83	85	32.9	200/230	2.2	10.5/9.7	78.0/82.6	100	47.6
LBK4-□/5-F-e	200	1.1	6.2	35	85	27.4	-	-	-	-	-	-
LBK4-□/6-F-e	200	1.1	6.2	35	85	32.9	-	-	-	-	-	-

Note 1) Discharge rate and total head are the values obtained in the test with a liquid viscosity of 1mm<sup>2</sup>/s (same as fresh water at normal temperature).  
 Note 2) The pump's current (current value listed on the pump nameplate) is the recommended current setting for protection device.

Assembly drawing

Fig.1  
 ●Output: 1.1kW (50/60Hz) or less

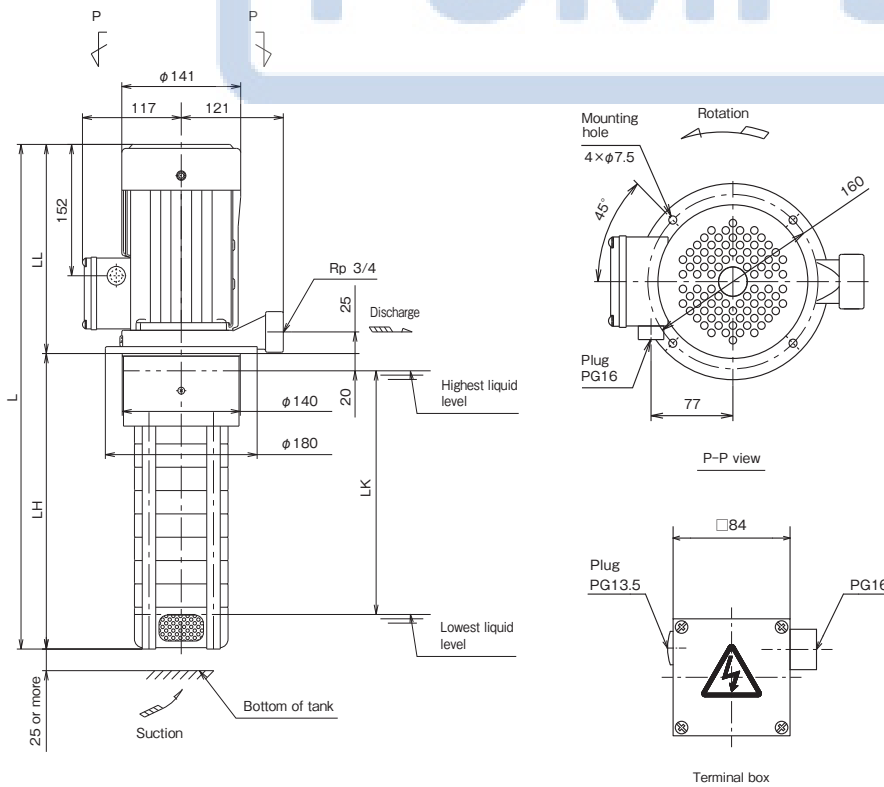

**■ Dimensions**

(Unit : mm)

Type	Fig.	L	LL	LH	LK	Approx. mass(kg)
LBK2-30/1-e	1	354	201	153	113	15
LBK2-40/1-e	1	372	201	171	131	15
LBK2-50/1-e	1	390	201	189	149	15
LBK2-60/1-e	1	408	201	207	167	15
LBK2-30/2-e	1	354	201	153	113	15
LBK2-40/2-e	1	372	201	171	131	15
LBK2-50/2-e	1	390	201	189	149	15
LBK2-60/2-e	1	408	201	207	167	15
LBK2-70/2-e	1	426	201	225	185	15
LBK2-80/2-e	1	444	201	243	203	16
LBK2-90/2-e	1	462	201	261	221	16
LBK2-100/2-e	1	480	201	279	239	16
LBK2-110/2-e	1	498	201	297	257	16
LBK2-30/3-e	1	354	201	153	113	15
LBK2-40/3-e	1	372	201	171	131	15
LBK2-50/3-e	1	390	201	189	149	15
LBK2-60/3-e	1	408	201	207	167	15
LBK2-70/3-e	1	426	201	225	185	15
LBK2-80/3-e	1	444	201	243	203	16
LBK2-90/3-e	1	462	201	261	221	16
LBK2-100/3-e	1	480	201	279	239	16
LBK2-110/3-e	1	498	201	297	257	16
LBK2-40/4-e	1	412	241	171	131	15
LBK2-50/4-e	1	430	241	189	149	15
LBK2-60/4-e	1	448	241	207	167	15
LBK2-70/4-e	1	466	241	225	185	15
LBK2-80/4-e	1	484	241	243	203	16
LBK2-90/4-e	1	502	241	261	221	16
LBK2-100/4-e	1	520	241	279	239	16
LBK2-110/4-e	1	538	241	297	257	16
LBK2-50/5-e	1	430	241	189	149	15
LBK2-60/5-e	1	448	241	207	167	15
LBK2-70/5-e	1	466	241	225	185	16
LBK2-80/5-e	1	484	241	243	203	16
LBK2-90/5-e	1	502	241	261	221	16
LBK2-100/5-e	1	520	241	279	239	16
LBK2-110/5-e	1	538	241	297	257	16
LBK2-60/6-e	1	448	241	207	167	15
LBK2-70/6-e	1	466	241	225	185	16
LBK2-80/6-e	1	484	241	243	203	16
LBK2-90/6-e	1	502	241	261	221	16
LBK2-100/6-e	1	520	241	279	239	16
LBK2-110/6-e	1	538	241	297	257	16
LBK2-70/7-e	1	466	241	225	185	16
LBK2-80/7-e	1	484	241	243	203	16
LBK2-90/7-e	1	502	241	261	221	16
LBK2-100/7-e	1	520	241	279	239	16
LBK2-110/7-e	1	538	241	297	257	16
LBK2-80/8-e	1	484	241	243	203	16
LBK2-90/8-e	1	502	241	261	221	16
LBK2-100/8-e	1	520	241	279	239	16
LBK2-110/8-e	1	538	241	297	257	16
LBK2-90/9-F-e	1	502	241	261	221	16
LBK2-100/9-F-e	1	520	241	279	239	16
LBK2-110/9-F-e	1	538	241	297	257	16
LBK2-100/10-F-e	1	520	241	279	239	16
LBK2-110/10-F-e	1	538	241	297	257	16
LBK2-110/11-F-e	1	538	241	297	257	16

(Unit : mm)

Type	Fig.	L	LL	LH	LK	Approx. mass(kg)
LBK4-20/1-e	1	354	201	153	113	14
LBK4-30/1-e	1	381	201	180	140	14
LBK4-40/1-e	1	408	201	207	167	14
LBK4-50/1-e	1	435	201	234	194	15
LBK4-60/1-e	1	462	201	261	221	15
LBK4-20/2-e	1	354	201	153	113	14
LBK4-30/2-e	1	381	201	180	140	14
LBK4-40/2-e	1	408	201	207	167	15
LBK4-50/2-e	1	435	201	234	194	15
LBK4-60/2-e	1	462	201	261	221	15
LBK4-70/2-e	1	489	201	288	248	15
LBK4-80/2-e	1	516	201	315	275	15
LBK4-90/2-e	1	543	201	342	302	16
LBK4-30/3-e	1	421	241	180	140	14
LBK4-40/3-e	1	448	241	207	167	15
LBK4-50/3-e	1	475	241	234	194	15
LBK4-60/3-e	1	502	241	261	221	15
LBK4-70/3-e	1	529	241	288	248	15
LBK4-80/3-e	1	556	241	315	275	16
LBK4-40/4-e	1	448	241	207	167	15
LBK4-50/4-e	1	475	241	234	194	15
LBK4-60/4-e	1	502	241	261	221	15
LBK4-70/4-e	1	529	241	288	248	15
LBK4-80/4-e	1	556	241	315	275	16
LBK4-90/4-e	1	583	241	342	302	16
LBK4-50/5-F-e	1	475	241	234	194	16
LBK4-60/5-F-e	1	502	241	261	221	16
LBK4-70/5-F-e	1	529	241	288	248	16
LBK4-80/5-F-e	1	556	241	315	275	16
LBK4-60/6-F-e	1	502	241	261	221	16
LBK4-70/6-F-e	1	529	241	288	248	16
LBK4-80/6-F-e	1	556	241	315	275	16

Assembly drawing

Fig.2

●Output: 1.2kW (50Hz), 1.5kW (60Hz) or more

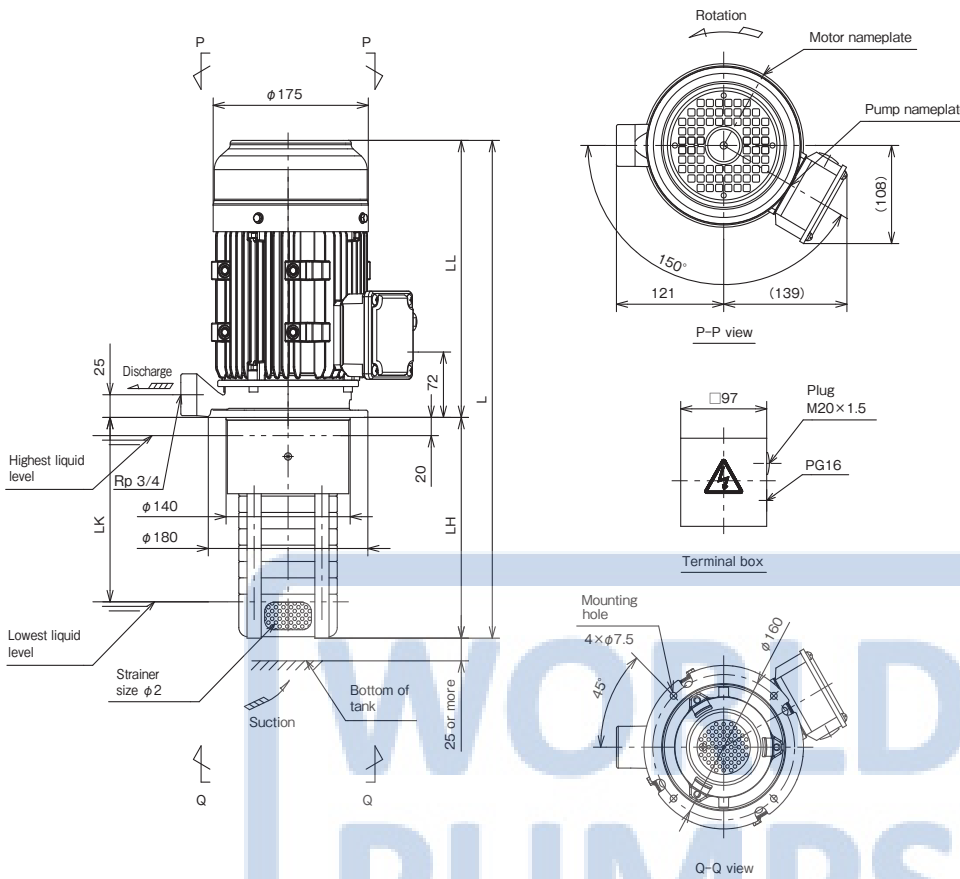

Dimensions

(Unit : mm)

(Unit : mm)

Type	Fig.	L	LL	LH	LK	Approx. mass(kg)
LBK2-80/8-H-e	2	548	305	243	203	23
LBK2-90/8-H-e	2	566	305	261	221	23
LBK2-90/9-e	2	566	305	261	221	23

Type	Fig.	L	LL	LH	LK	Approx. mass(kg)
LBK4-50/5-e	2	539	305	234	194	22
LBK4-60/5-e	2	566	305	261	221	22
LBK4-60/6-e	2	566	305	261	221	25
LBK4-70/6-e	2	593	305	288	248	26
LBK4-80/6-e	2	620	305	315	275	26
LBK4-90/6-e	2	647	305	342	302	26

Detailed drawing of the terminal box

Assembly drawing

● Output: 1.1kW (50/60Hz) or less

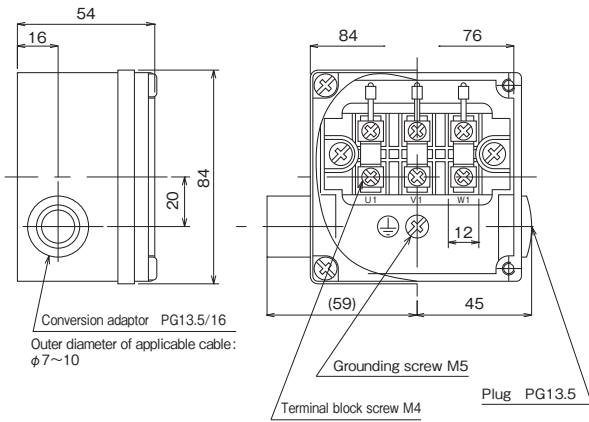

Connection diagram

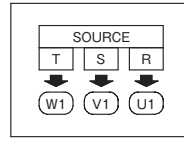

● Output: 1.2kW (50Hz), 1.5kW (60Hz) or more

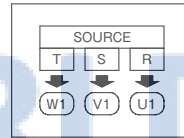
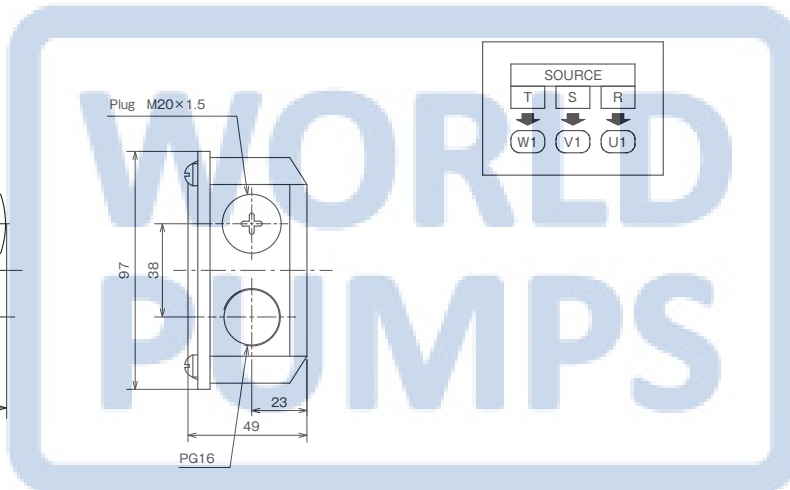
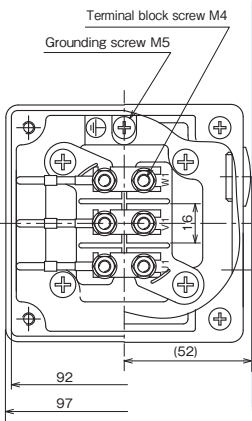

## Sectional drawing

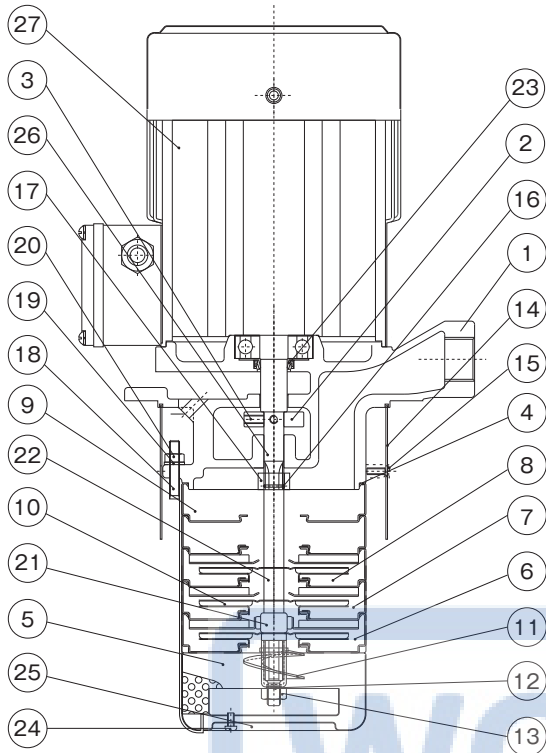

No.	Part name	Material
1	Discharge casing	FC200
2	Oil thrower	SUS304
3	Set screw	SCM435
4	Gasket	—
5	Suction casing	SUS304
6	Intermediate casing (First stage)	SUS304
7	Bearing casing	SUS304+SiC
8	Intermediate casing	SUS304
9	Intermediate casing (Last stage)	SUS304
10	Impeller	SUS304
11	Screw	SUS304
12	Washer	SUS304
13	Impeller nut	SUS304
14	Outer sleeve	SUS304
15	Cross recessed flat head screw	SUS304
16	Shaft ring	SUS316
17	Shaft pushing	SUS304
18	Bolt for fastening plate	SUS304
19	Washer	SUS304
20	Hexagon nut	SUS304
21	Bearing	SiC
22	Sleeve	SUS304
23	Oil seal	NBR
24	Cross recessed pan head screw	SUS304
25	Strainer	SUS304
26	Main shaft (motor side+pump side)	S45C+SUS431
27	Motor	—

Note 1) The materials in the table above are equivalents.

Note 2) Structure and other details are subject to change without notice.

WORLD  
PUMPS



■ Features

- ① An energy-saving pump with a Top Runner efficiency (equivalent to IE3) motor (LPW-e).
- ② Strong and tough enough to resist dirty coolants.
- ③ Highly durable due to FCD, the impeller's material and the non-seal (mechanical seal-less) structure.
- ④ Mounting the inlet piping allows you to freely set the operating water level (LPW40-e/LPW65-e).
- ⑤ Can be used for high viscosity coolants (LPW40-e/LPW65-e).
- ⑥ Diverse lineup compatible with various efficiencies.

LPW-e type: Equipped with a Top Runner efficiency (equivalent to IE3) motor.  
(5.5 to 7.5kW is NEMA Premium motor)

LPW-7W type: Equipped with a UL-approved motor (NEMA premium efficiency) (3.0kW or less).



Please note that the paint color, etc. of the actual unit may partially differ from the photo.

■ Description of types

Bore diameter 40mm **LPW 40 1 C - 0.75 -e**

Bore diameter 50/65mm **LPW 65 3 /2 A - 6 5.5 L -e**

- ① Model
- ② Bore diameter
- ③ Number of casings
- ④ Number of impellers  
(blank if number is equal to number of casings)
- ⑤ Viscosity of liquid  
A, C : for low viscosity liquid  
D : for high viscosity liquid
- ⑥ Frequency 5:50Hz 6:60Hz
- ⑦ Output
- ⑧ ID code
- ⑨ Motor efficiency  
-e : Top Runner efficiency (equivalent to IE3)  
-7W : UL approved motor (3.0kW or less is NEMA Premium efficiency)

■ Standard Specification

Bore diameter		40mm	50mm	65mm
Used liquid	Property of liquid	Coolants of the kinematic viscosity equivalent to that of water-soluble coolants or water containing an additive (anticorrosive, etc.) <sup>*1</sup>		Water-soluble coolant liquid <sup>*1</sup>
	Temperature	0 to 60°C (No frozen liquid)		
	Allowable kinematic viscosity	40C : 32mm <sup>2</sup> /s 40D : 150mm <sup>2</sup> /s	1mm <sup>2</sup> /s	
Installation location		Indoor Ambient temperature: 0 to 40 °C, RH 85% or below (no condensation), Height above sea level : 1000m or less, Place not exposed to direct sunlight, Place in an area free of corrosive or explosive gas or vapor.		
Material	Casing Suction • Discharge • Intermediate	FC200		
	Impeller	FCD450		
	Shaft	S35C	S45C	
Sealing structure		Non-seal (mechanical seal-less)		
Motor	Power source	3-phase 50/60/60Hz 200/200/220V <sup>*2*</sup>		
	Type	Totally enclosed fan-cooled, indoor type	Totally enclosed fan cooled outdoor type <sup>*4</sup>	
	Protection method <sup>*5</sup>	IP44	IP55	
	Thermal class	F		
	Rating	Continuous		
Number of poles		2P		
Paint color		Munsell N1.5		

\*1 Take note that special liquid such as water, printing liquid or acid liquid cannot be used. Contact us for other special liquid (ceramic, etc.).

\*2 -7W type: 60Hz 208/230/460V

\*3 LPW65-e: 3-phase 50/60/60Hz 200/200/230V

\*4 We cannot set the pump outside.

\*5 -7W type: IP54

■ Special specification

Shaft structure change (wear resistance improvement)
--

■ Table of Consumable Parts

Output (kW)	Specification	Bearing		Oil seal	
		Load side	Unload side	Load side	Unload side
0.75	-e	6306ZZC3	6203ZZC3	VC30508	—
1.5		6306ZZC3	6303ZZC3		
2.2		6306ZZC3	6303ZZC3		
3.0		6307ZZC3	6205ZZC3		
5.5	-7W	6309ZZC3	6306ZZC3	VC45628	VC30528
7.5		6309ZZC3	6306ZZC3	SC30457	HM25385
0.75		6306ZZC3	6203ZZCM		
1.5	6306ZZC3	6205ZZCM			
2.2	-7W	6306ZZC3	6205ZZCM	SC30457	HM25385
3.0		6307ZZC3	6205ZZCM		

Bore diameter (mm)	O-ring (for companion flange)	O-ring (for water seal plate)
50	S67	—
65	—	S66

Selection chart

● LPW40

● For low viscosity liquid (Values at kinematic viscosity 1mm<sup>2</sup>/s, specific gravity 1)

50Hz

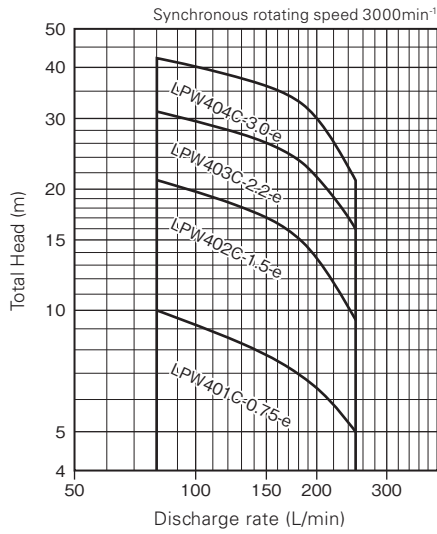

60Hz

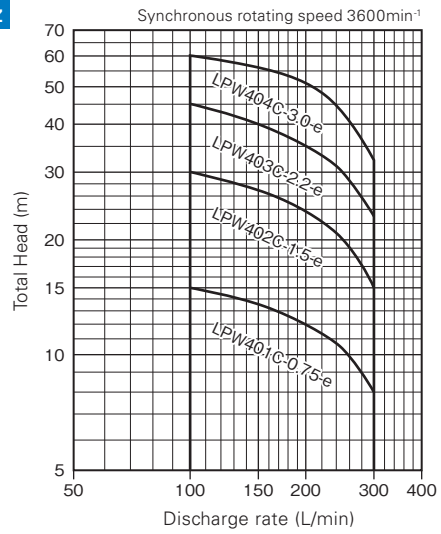

● For high-viscosity liquid (Value at 150 mm<sup>2</sup>/s kinematic viscosity, specific gravity 1)

50Hz

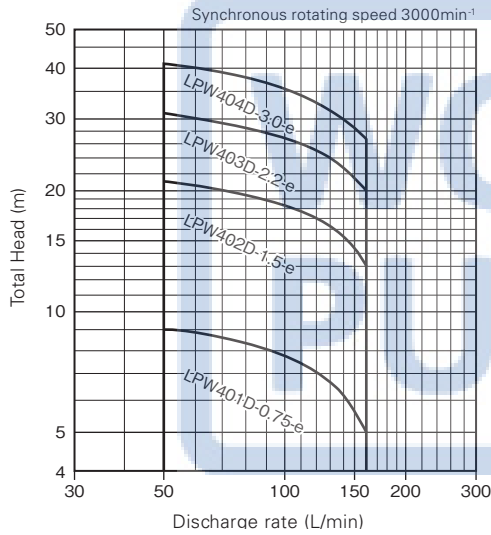

60Hz

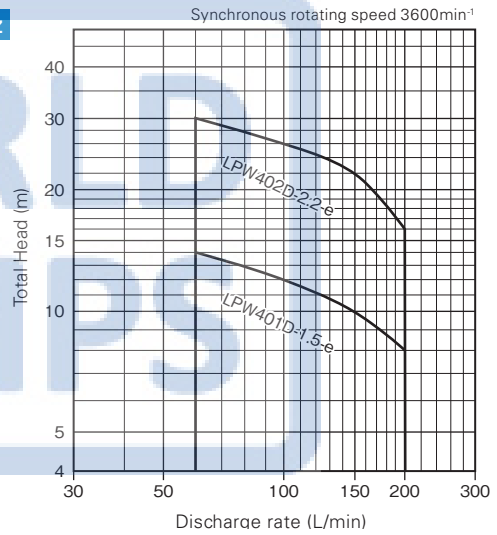

※ This also applies to -7W type.

■ Specification table

● LPW40

Bore diameter (mm)	Frequency (Hz)	Used liquid	Output (kW)	Type	Rated voltage (V)	Rated current (A)	Starting current (A)	Discharge rate (L/min)	Total head (m)
40	50	For low viscosity liquid	0.75	LPW401C-0.75-e	200	3.5	30.0	80~250	10~5
			1.5	LPW402C-1.5-e	200	5.6	66.0		21~9.5
			2.2	LPW403C-2.2-e	200	8.0	84.0		31~16
			3.0	LPW404C-3.0-e	200	13.0	180		42~21
		For high-viscosity liquid	0.75	LPW401D-0.75-e	200	4.0	30.0	50~160	9~5
			1.5	LPW402D-1.5-e	200	6.6	66.0		21~13
			2.2	LPW403D-2.2-e	200	9.5	84.0		31~20
			3.0	LPW404D-3.0-e	200	14.8	180		41~27
	60	For low viscosity liquid	0.75	LPW401C-0.75-e	200/220	3.8/3.8	29.0/32.0	100~300	15~8
				LPW401C-0.75-7W	208/230/460	4.0/3.9/2.0	33.9/38.0/19.0		30~15
			1.5	LPW402C-1.5-e	200/220	6.5/6.0	64.0/70.0		45~23
				LPW402C-1.5-7W	208/230/460	6.5/6.0/3.1	47.3/52.0/26.0		
			2.2	LPW403C-2.2-e	200/220	9.0/8.4	73.0/80.0		64~32
				LPW403C-2.2-7W	208/230/460	8.9/8.5/4.3	74.8/83.0/41.5		
			3.0	LPW404C-3.0-e	200/220	13.0/13.0	152/167		60~200
				LPW404C-3.0-7W	208/230/460	12.5/11.8/6.0	119.4/130/65.0		
For high-viscosity liquid		1.5	LPW401D-1.5-e	200/220	6.5/6.0	64.0/70.0	14~8		
			LPW401D-1.5-7W	208/230/460	6.5/6.0/3.1	47.3/52.0/26.0			
		2.2	LPW402D-2.2-e	200/220	9.0/8.4	73.0/80.0		30~16	
			LPW402D-2.2-7W	208/230/460	8.9/8.5/4.3	74.8/83.0/41.5			

Note 1) Discharge rate and total head are the values obtained in the tests with a liquid viscosity of 1mm<sup>2</sup>/s (same as fresh water at normal temperature).  
 Note 2) The pump's rated current (current value listed on the pump nameplate) is the recommended current setting for protection device.

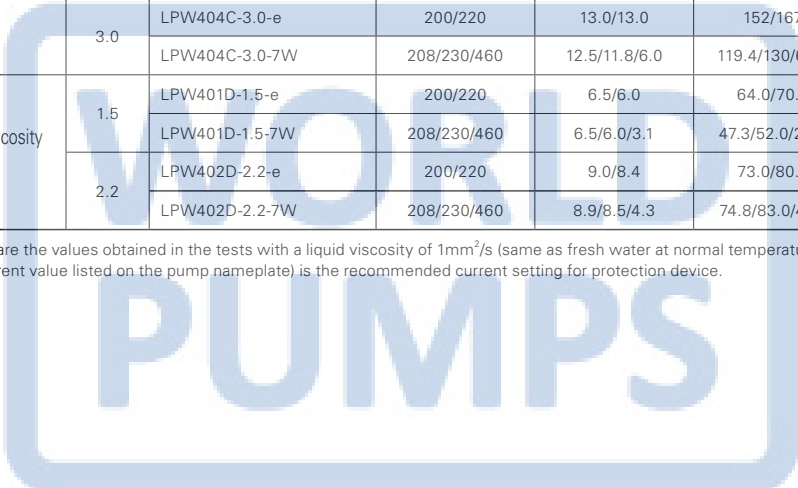

Selection chart

● LPW50

(Values at kinematic viscosity 1mm<sup>2</sup>/s, specific gravity 1)

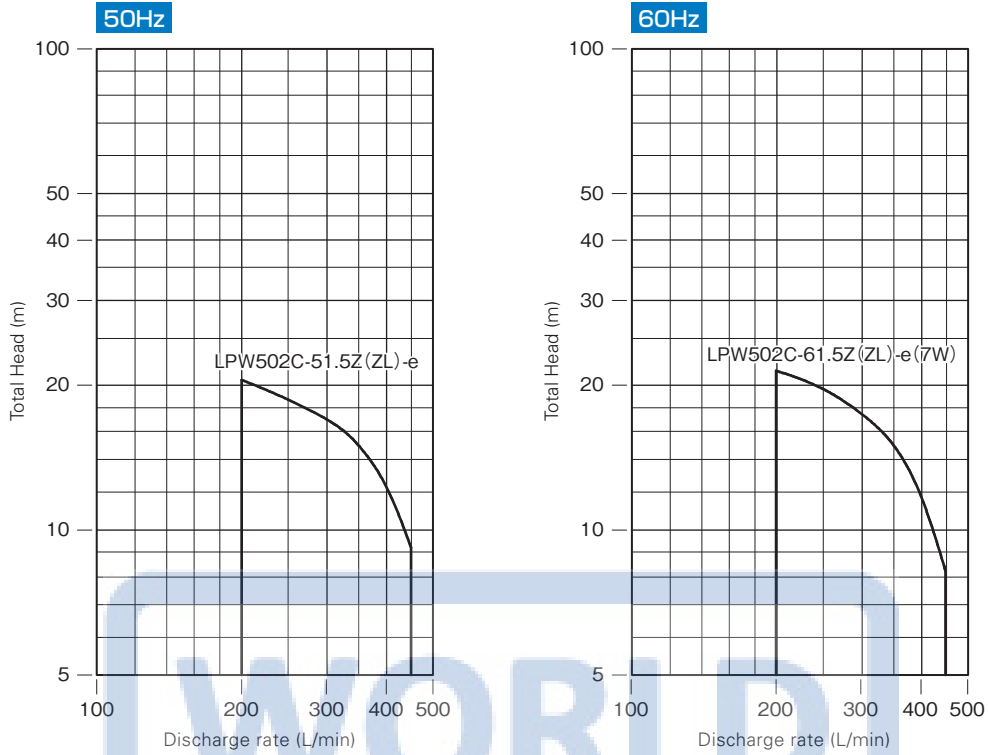

Specification table

● LPW50

Bore diameter (mm)	Frequency (Hz)	Output (kW)	Type	Rated voltage (V)	Rated current (A)	Starting current (A)	Discharge rate (L/min)	Total head (m)
50	50	1.5	LPW502C-51.5Z-e	200	6.6	66.0	200~450	20.5~9
			LPW502C-51.5ZL-e					
	60		LPW502C-61.5Z-e	200/220	6.5/6.0	64.0/70.0	200~450	21~8
			LPW502C-61.5ZL-e					
			LPW502C-61.5ZL-7W					

Note) The pump's rated current (current value listed on the pump nameplate) is the recommended current setting for protection device.

Selection chart

●LPW65

●For low viscosity liquid (Values at kinematic viscosity 1mm<sup>2</sup>/s, specific gravity 1)

50Hz

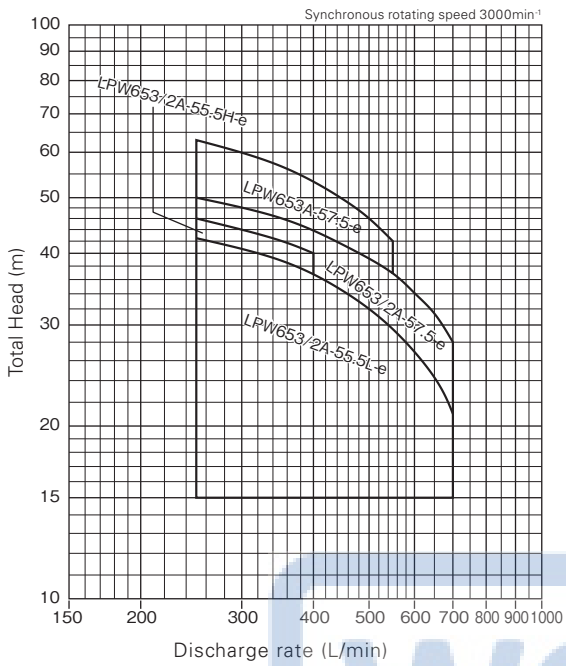

60Hz

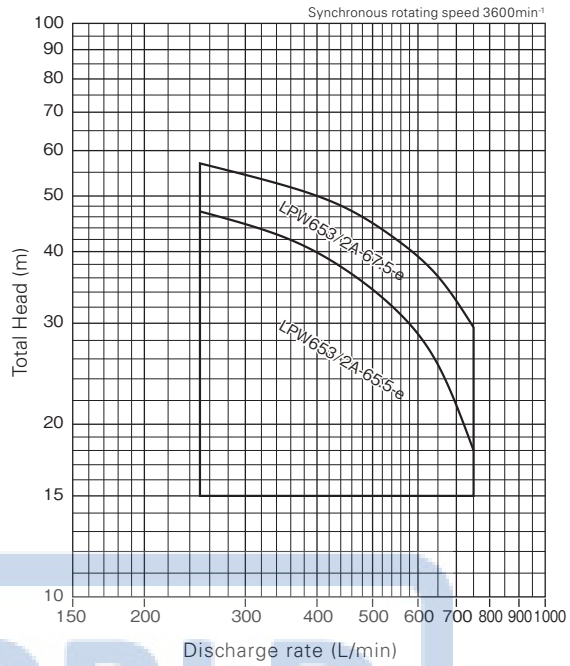

Specification table

● LPW65

Bore diameter (mm)	Frequency (Hz)	Output (kW)	Type	Rated voltage (V)	Rated current (A)	Starting current (A)	Discharge rate (L/min)	Total head (m)
65	50	5.5	LPW653/2A-55.5L-e	200	20.3	204	250~700	42.5~21
		5.5	LPW653/2A-55.5H-e		20.3	204	250~400	46~40
		7.5	LPW653/2A-57.5-e		27.2	288	250~700	50~28
		7.5	LPW653A-57.5-e		27.2	288	250~550	63~42
	60	5.5	LPW653/2A-65.5-e	200/230	19.8/17.8	178/206	250~750	47~18
		7.5	LPW653/2A-67.5-e		26.5/23.7	254/295	250~750	57~29.5

Note) The pump's rated current (current value listed on the pump nameplate) is the recommended current setting for protection device.

Assembly drawing

●LPW40-e

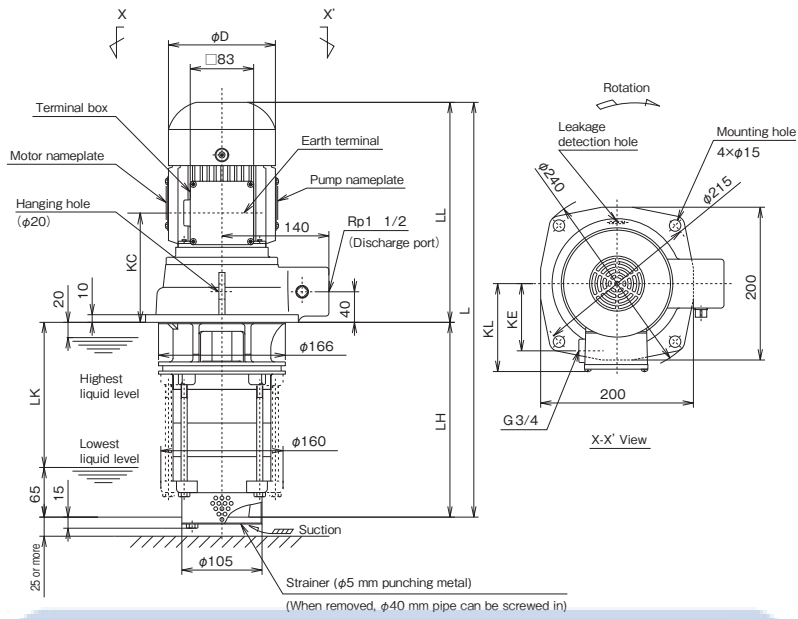

Dimensions

●LPW40-e

(Unit : mm)

Bore diameter (mm)	Used liquid	Frequency (Hz)	Type	D	KC	KE	KL	L	LH	LK	LL	Approx. mass(kg)
40	For low viscosity	50/60	LPW401C-0.75-e	140	143	88	115	543	255	190	288	28
			LPW402C-1.5-e	175	143	103	130	588	255	190	333	35
			LPW403C-2.2-e	175	143	103	130	588	255	190	333	42
			LPW404C-3.0-e	195	145	113	140	663	299	234	364	49
	For high viscosity	50	LPW401D-0.75-e	140	143	88	115	543	255	190	288	28
			LPW402D-1.5-e	175	143	103	130	588	255	190	333	35
			LPW403D-2.2-e	175	143	103	130	588	255	190	333	42
			LPW404D-3.0-e	195	145	113	140	663	299	234	364	49
		60	LPW401D-1.5-e	175	143	103	130	588	255	190	333	34
			LPW402D-2.2-e	175	143	103	130	588	255	190	333	41

Assembly drawing

●LPW40-7W 0.75kW

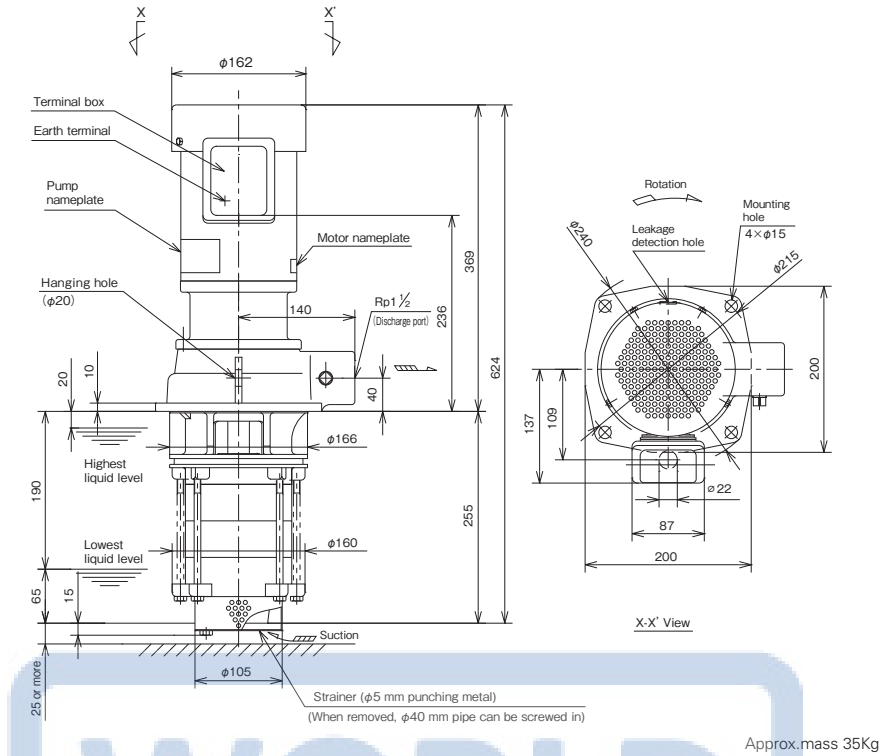

●LPW40-7W 1.5kW or more

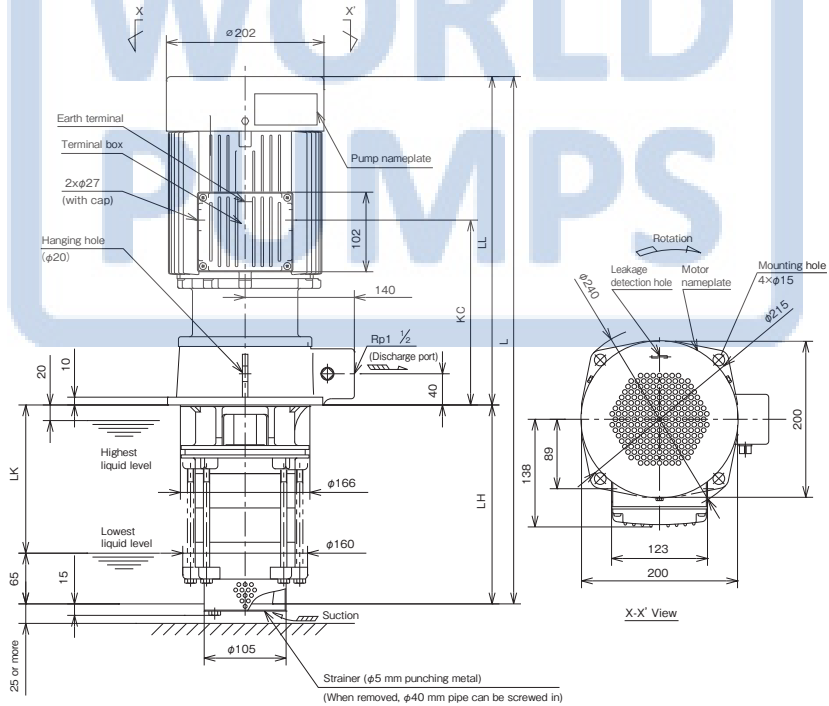

Dimensions

●LPW40-7W 1.5kW or more

(Unit : mm)

Bore diameter (mm)	Used liquid	Frequency (Hz)	Type	KC	L	LH	LK	LL	Approx. mass(kg)
40	For low viscosity	60	LPW402C-1.5-7W	237	676	255	190	421	45
			LPW403C-2.2-7W	237	676	255	190	421	52
			LPW404C-3.0-7W	240	743	299	234	444	59
	For high viscosity		LPW401D-1.5-7W	237	676	255	190	421	44
			LPW402D-2.2-7W	237	676	255	190	421	51

Assembly drawing

●LPW50-e

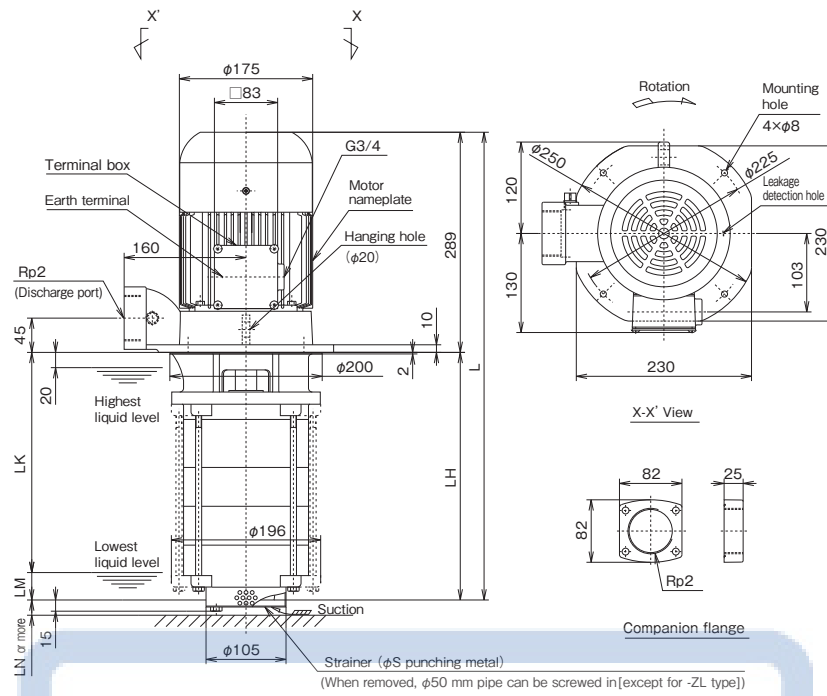

Dimensions

●LPW50-e

(Unit : mm)

Bore diameter (mm)	Frequency (Hz)	Type	LH	LK	LM	LN	L	S	Approx. mass(kg)
50	50	LPW502C-51.5Z-e	219	168	51	25	508	6	40
	60	LPW502C-61.5Z-e							
	50	LPW502C-51.5ZL-e	325	289	36	20	614	6	
	60	LPW502C-61.5ZL-e							

●LPW502C-61.5ZL-7W

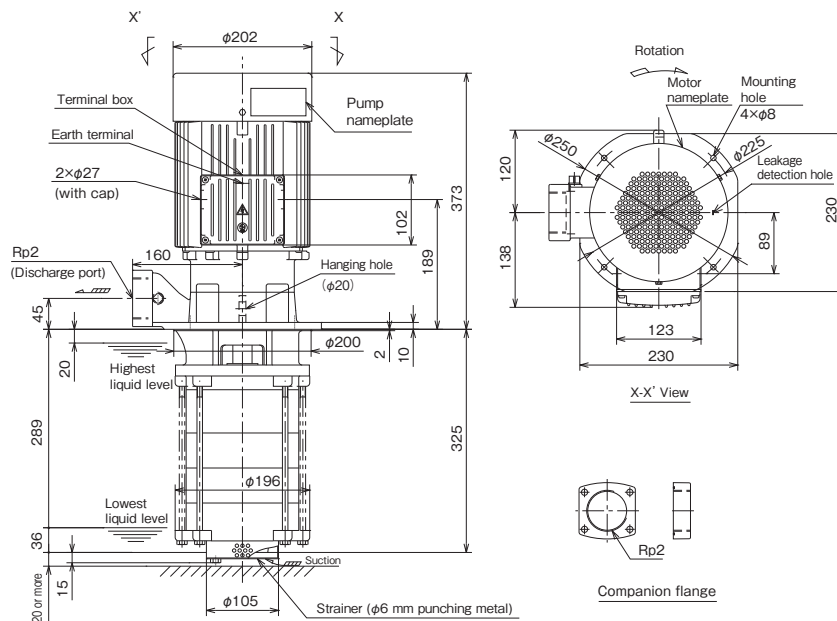

Approx.mass 55Kg



Assembly drawing

●LPW65-e

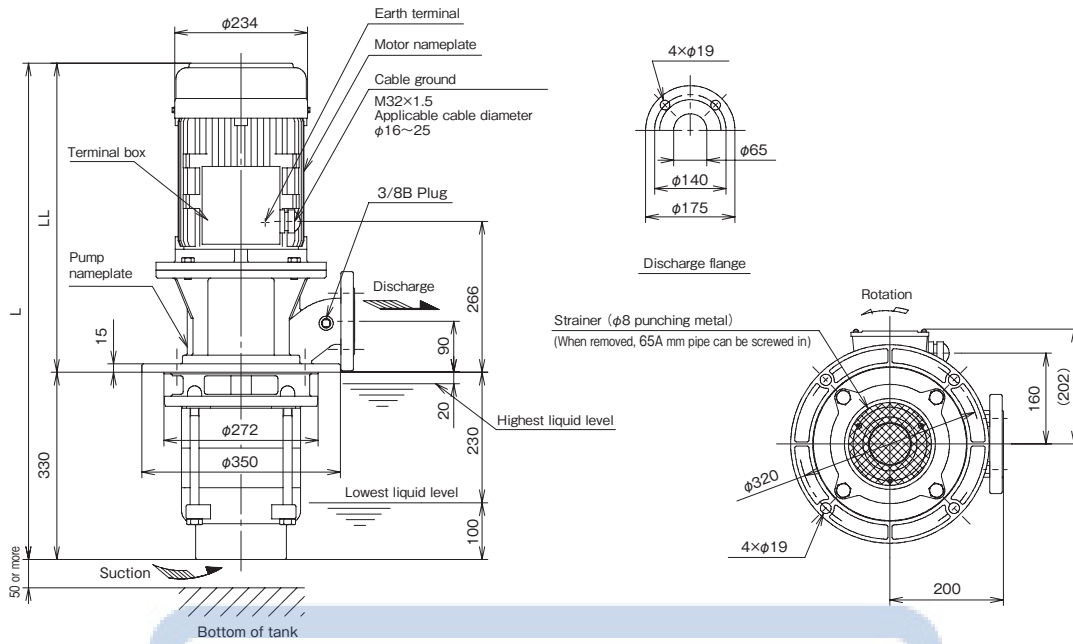

Dimensions

●LPW65-e

(Unit : mm)

Bore diameter (mm)	Frequency (Hz)	Type	LL	L	Approx. mass(kg)
65	50	LPW653/2A-55.5L-e	545	875	97
		LPW653/2A-55.5H-e			97
		LPW653/2A-57.5-e	585	915	100
		LPW653A-57.5-e			102
	60	LPW653/2A-65.5-e	545	875	97
		LPW653/2A-67.5-e	585	915	100

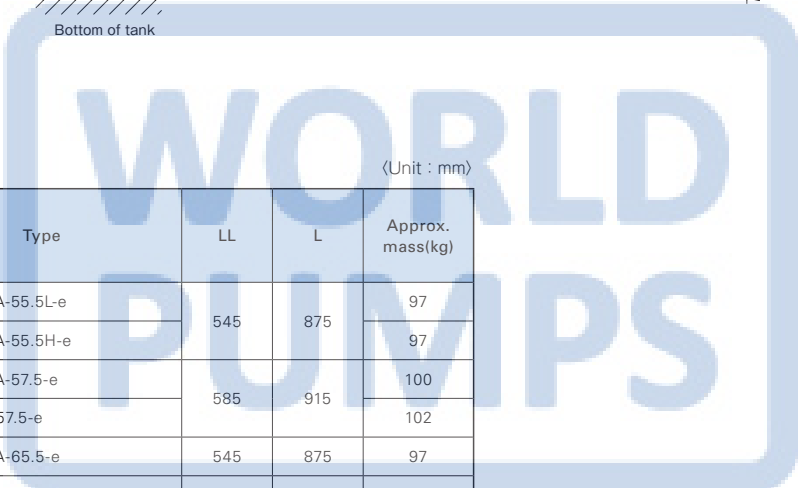

Detailed drawing of the terminal box

● LPW40-e, LPW50-e

■ Assembly drawing

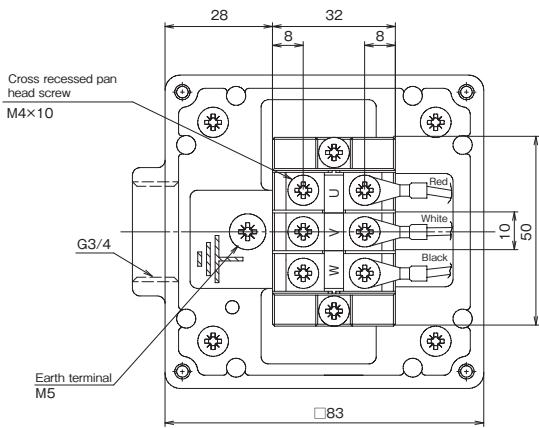

● LPW65-e

■ Assembly drawing

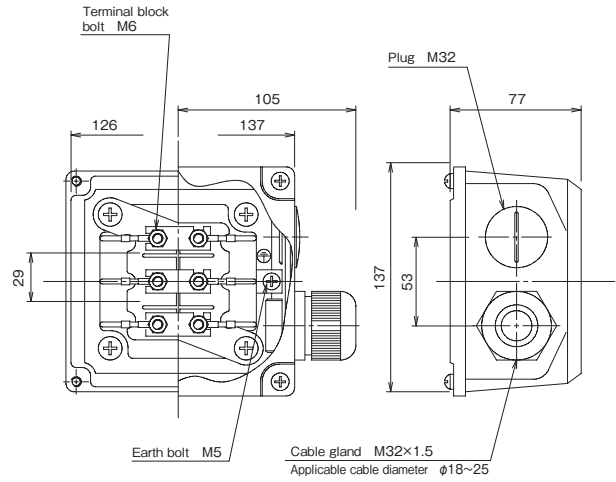

● LPW40-e, LPW50-e

■ Connection diagram

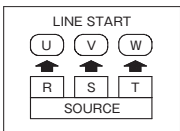

● LPW65-e

■ Connection diagram

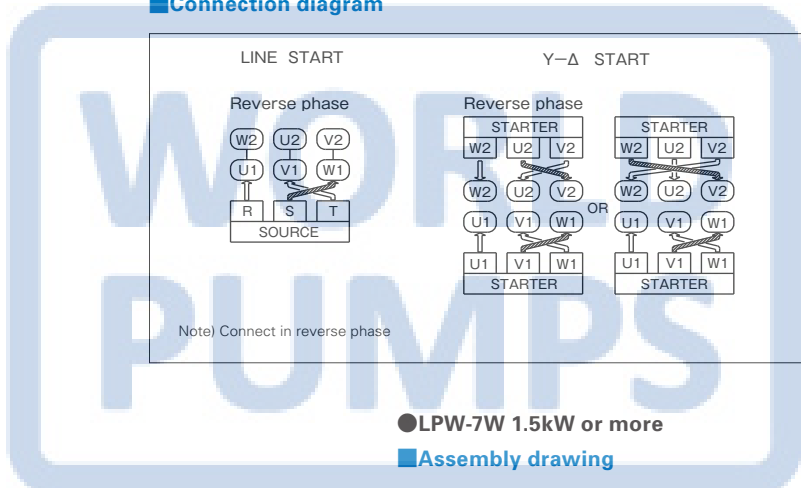

● LPW-7W 0.75kW

■ Assembly drawing

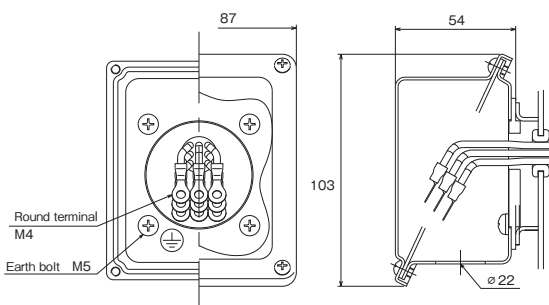

● LPW-7W 1.5kW or more

■ Assembly drawing

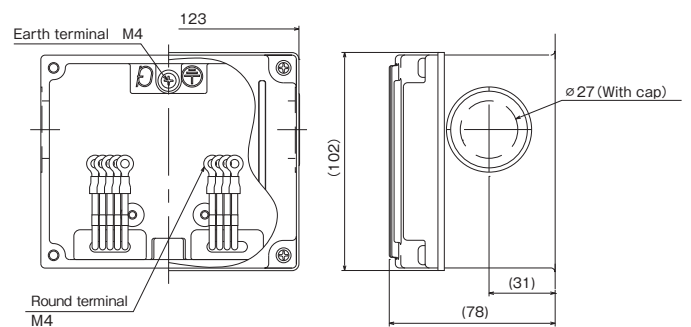

● LPW-7W Full output

■ Connection diagram

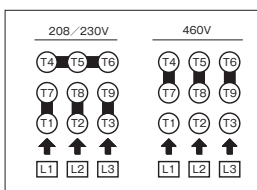

Sectional drawing

●LPW40

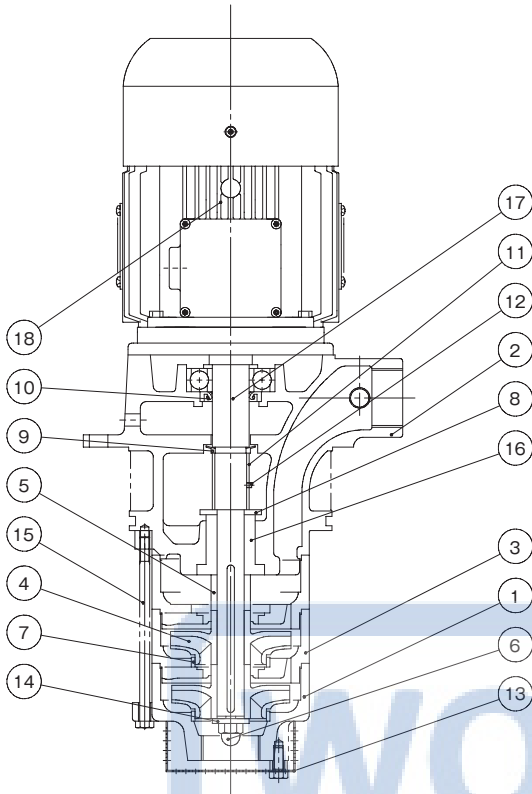

No.	Part name	Qty	Material
1	Suction casing	1	FC200
2	Discharge casing	1	FC200
3	Intermediate casing	2	FC200
4	Impeller	2	FCD450
5	Shaft spacer	1	STS
6	Impeller nut	1	SUS304
7	Liner ring	2	SUS304
8	Deflector	1	SS400
9	Deflector	1	NBR
10	Oil seal	1	NBR
11	Collar	1	STKM
12	Hexagon socket set screw	1	SCM435
13	Strainer	1	SPCC
14	Washer	1	SUS420J1
15	Through bolt	4	SS400
16	Shaft sleeve	1	FCD450
17	Main shaft	1	S35C
18	Motor	1	

Applicable models : LPW402C-1.5-□, LPW402D-1.5-□, LPW402D-2.2-□

Note 1) The materials in the table above are equivalents.

Note 2) Structure and other details are subject to change without notice.

●LPW50-ZL

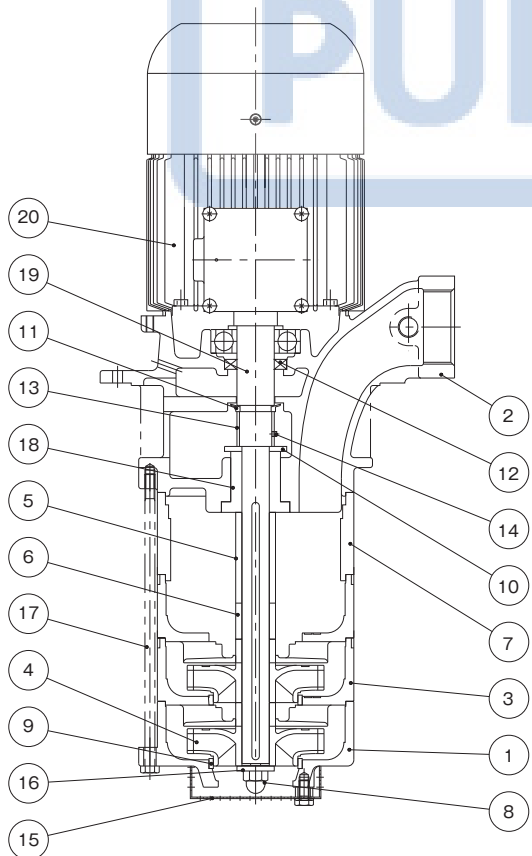

No.	Part name	Qty	Material
1	Suction casing	1	FC200
2	Discharge casing	1	FC200
3	Intermediate casing	2	FC200
4	Impeller	2	FCD450
5	Shaft spacer	1	STS
6	Shaft spacer	1	STS
7	Intermediate spacer	1	STKM13A
8	Impeller nut	1	SUS304
9	Liner ring	2	SUS304
10	Deflector	1	SS400
11	Deflector	1	NBR
12	Oil seal	1	NBR
13	Collar	1	STKM
14	Hexagon socket set screw	1	SCM435
15	Strainer	1	SS400
16	Washer	1	SUS420J1
17	Through bolt	4	SS400
18	Shaft sleeve	1	FCD450
19	Main shaft	1	S35C
20	Motor	1	

Note 1) The materials in the table above are equivalents.

Note 2) Structure and other details are subject to change without notice.

Sectional drawing

●LPW65

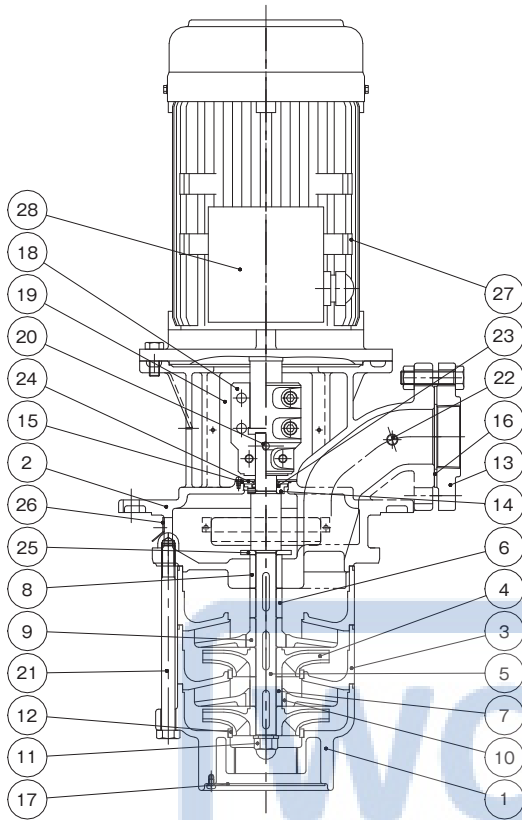

No.	Part name	Qty	Material
1	Suction casing	1	FC200
2	Discharge casing	1	FC200
3	Intermediate casing	2	FC200
4	Impeller	2	FCD450
5	Main shaft	1	S45C
6	Shaft sleeve A	2	SUS304
7	Shaft sleeve B	1	SiC
8	Shaft sleeve C	1	SUS304
9	Shaft sleeve D	1	SUS304
10	Intermediate bushing	1	SiC
11	Impeller nut	1	SUS304
12	Liner ring	2	SUS304
13	Companion flange	1	FC200
14	Deflector	1	C3604B
15	O-ring	1	NBR
16	Sheet packing	1	NBR
17	Strainer	1	SPCC
18	Coupling	1	FC200
19	Coupling cover	2	SUS304
20	Hexagon socket set screw	1	SCM435
21	Through bolt	4	SS400
22	Plug	1	SS400
23	V-ring	1	FKM
24	Coolant sealing plate	1	SUS304
25	Deflector	1	SUS304
26	Cover	3	SUS304
27	Motor	1	
28	Terminal box	1	SPCC

Note 1) The materials in the table above are equivalents.  
 Note 2) Structure and other details are subject to change without notice.  
 Applicable models: 50Hz LPW653/2A-55.5L-□, LPW653/2A-55.5H-□, LPW653/2A-57.5-□  
 60Hz LPW653/2A-65.5-□, LPW653/2A-67.5-□

**Features**

- ① Energy-saving pump equipped with a Top Runner efficiency (equivalent to IE3) motor.
- ② As the immersion length is as short as 330mm in all models, tank depths can be reduced.
- ③ Serial operation allows generating up to 3.92 MPa.\*
- ④ The fluid level during operation can be adjusted as preferred by connecting the intake piping.
- ⑤ As a non-seal (mechanical seal-less) structure is adopted, the pump is highly durable.
- ⑥ Stainless steel and special resin with high reliability are used in the pump's main unit.
- ⑦ The connecting dimensions are compatible with those of conventional pumps.

\*The value is for reference only.



Please note that the paint color, etc. of the actual unit may partially differ from the photo.

**Description of types**

**LKW 20 09 -6 3.0 D -e**

- ①
- ②
- ③
- ④
- ⑤
- ⑥
- ⑦

- ① Model
- ② Bore diameter
- ③ Number of impellers
- ④ Frequency 5: 50Hz 6: 60Hz
- ⑤ Output
- ⑥ Operating method  
None: single operation  
D : series operation
- ⑦ Motor efficiency Top Runner efficiency (equivalent to IE3)

**Standard Specification**

Used liquid	Property of liquid	Water-soluble coolant liquid
	Temperature	0 to 60°C (No frozen liquid)
	Allowable kinematic viscosity	1mm <sup>2</sup> /s
Installation location		Indoor Ambient temperature: 0 to 40 °C, RH 85% or below (no condensation), Height above sea level : 1000m or less, Place not exposed to direct sunlight, Place in an area free of corrosive or explosive gas or vapor.
Material	Suction cover - Discharge casing	FC200
	Intermediate casing	ARLS* +SUS304
	Impeller	ARLS*
	Shaft	S35C
Shaft seal structure		Non-seal (mechanical seal-less)
Motor	Power source	3-phase 50/60/60 Hz, 200/200/220 V
	Type	Totally enclosed fan-cooled, indoor type
	Protection method	IP44
	Thermal class	F
	Rating	Continuous
Number of poles		2P
Paint color		Munsell N1.5

\* Special polyamide resin reinforced with glass fiber, etc.

**Table of Consumable Parts**

Output (kW)	Bearing		Oil seal	O-ring (For intermediate casing and spacer.)
	Load side	Unload side		
2.2	6306ZZC3	6303ZZC3	VC30456	G135
3.0	6308ZZC3	6205ZZC3	VC40586	
4.0	6308ZZC3	6205ZZC3	VC40586	

Selection chart

(Values at kinematic viscosity 1mm<sup>2</sup>/s, specific gravity 1)

50Hz

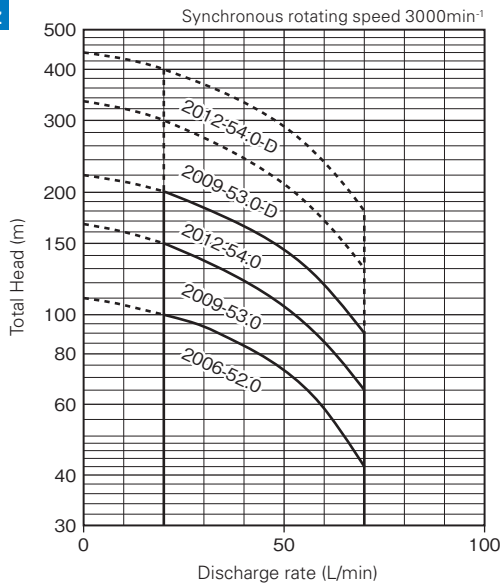

60Hz

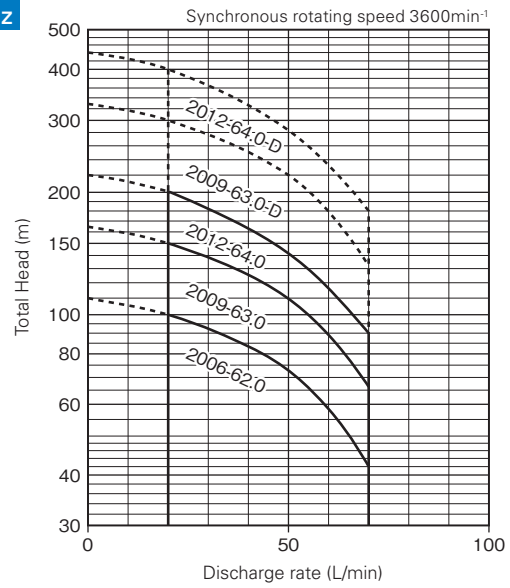

— Single operation  
- - - Series operation

Specification table

Bore diameter (mm)	Frequency (Hz)	Type	Rated voltage (V)	Output (kW)	Rated current (A)	Starting current (A)	Discharge rate (L/min)	Total head (m)
20	50	LKW2006-52.0-e	200	2.2	9.3	84	20~70	100~42
		LKW2009-53.0-e		3.0	14.8	180	20~70	150~65
		LKW2012-54.0-e		4.0	16.0	179	20~70	200~90
		LKW2009-53.0-D-e		3.0	14.8	180	20~70	300~130
		LKW2012-54.0-D-e		4.0	16.0	179	20~70	400~180
	60	LKW2006-62.0-e	200/220	2.2	8.4/7.9	73/80	20~70	100~43
		LKW2009-63.0-e		3.0	12.0/12.1	152/167	20~70	150~67
		LKW2012-64.0-e		4.0	15.0/14.0	152/173	20~70	200~90
		LKW2009-63.0-D-e		3.0	12.0/12.1	152/167	20~70	300~134
		LKW2012-64.0-D-e		4.0	15.0/14.0	152/173	20~70	400~180

Notes 1) The pump's rated current (current value listed on the pump nameplate) is the recommended current setting for protection device.

Notes 2) The rated current and the starting current value in the table above are the values per unit.

Assembly drawing

Single operation

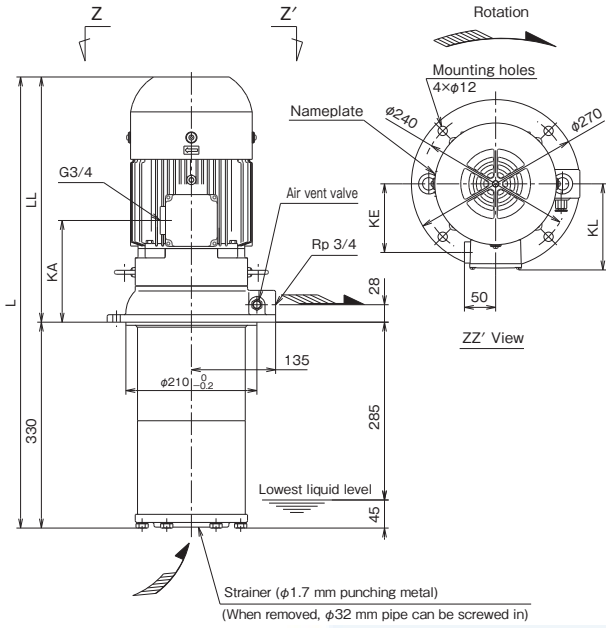

Dimensions

Single operation

(Unit : mm)

Bore diameter (mm)	Frequency (Hz)	Type	L	LL	KA	KE	KL	Approx. mass(kg)
20	50	LKW2006-52.0-e	693	363	158	100	128	47
		LKW2009-53.0-e	723	393	163	110	138	55
		LKW2012-54.0-e	736	406	176	110	138	68
20	60	LKW2006-62.0-e	693	363	158	100	128	47
		LKW2009-63.0-e	723	393	163	110	138	55
		LKW2012-64.0-e	736	406	176	110	138	68

Series operation

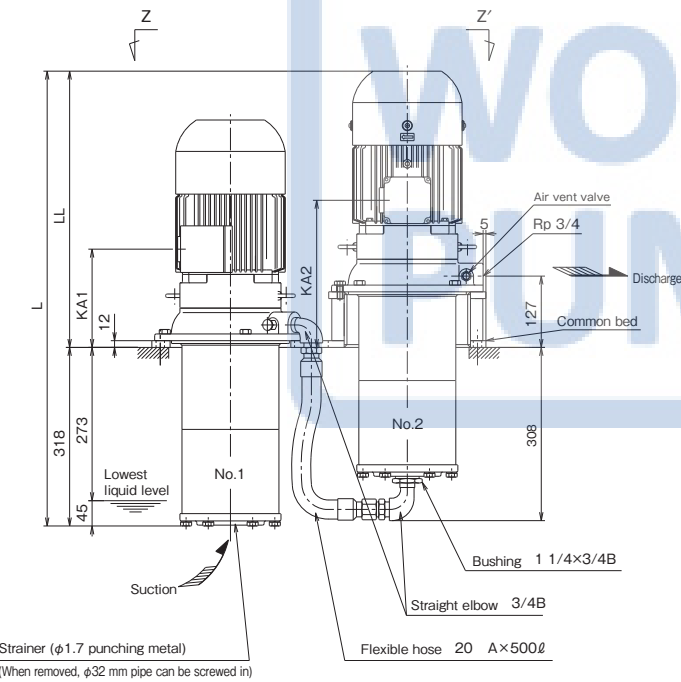

Series operation

(Unit : mm)

Bore diameter (mm)	Frequency (Hz)	Type	KA1	KA2	LL	L	Approx. mass(kg)
20	50	LKW2009-53.0-D-e	175	188	492	810	128
		LKW2012-54.0-D-e	262	275	505	823	152
20	60	LKW2009-63.0-D-e	175	188	492	810	128
		LKW2012-64.0-D-e	262	275	505	823	152

In the case of series operation, we ship the pumps and the accompanying components in separate packages. Please assemble them at your site.

Detailed drawing of the terminal box

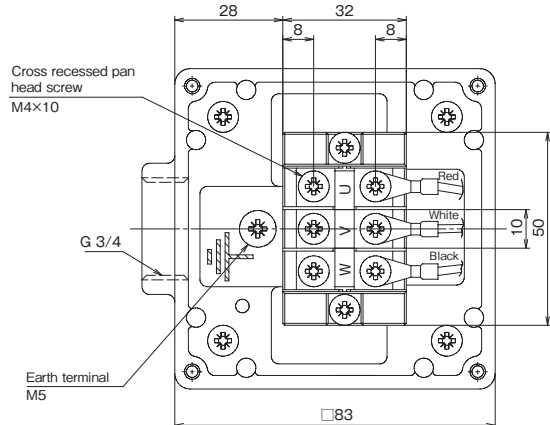
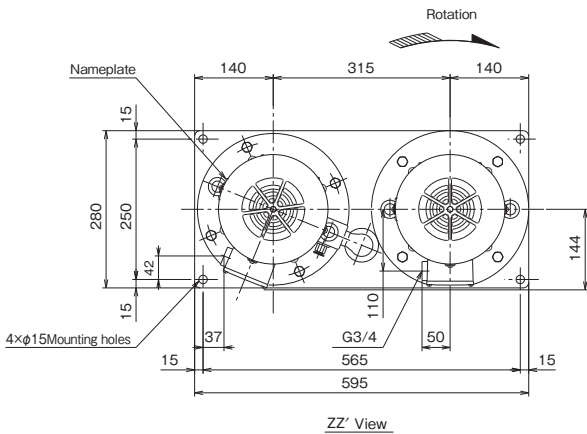

## Sectional drawing

n: Number of stages

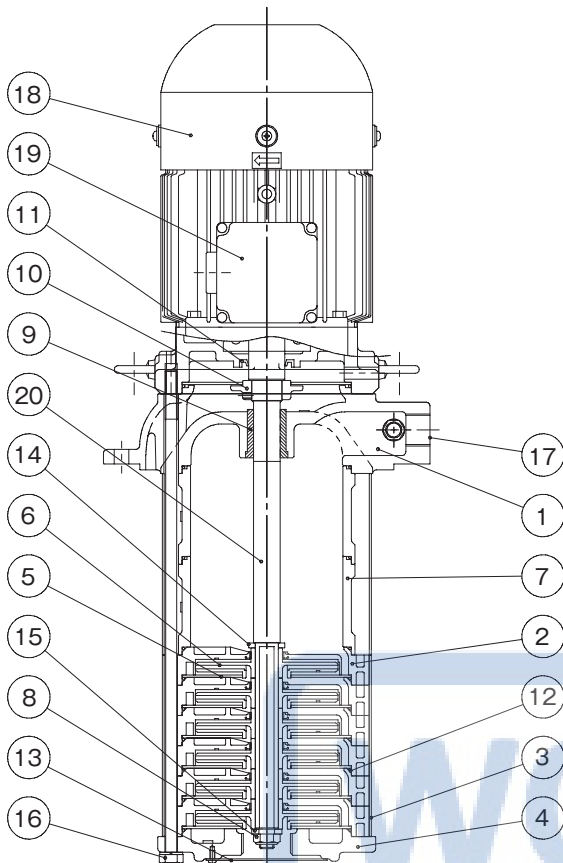

No.	Part name	Qty	Material
1	Discharge casing	1	FC200
2	Intermediate casing	n	ARLS <sup>SM</sup> + (SUS304)
3	Outer casing	2	SUS304
4	Suction cover	1	FC200
5	Casing cover	n + 1	SUS304
6	Impeller	n	ARLS
7	Intermediate spacer	※2	FC200
8	Impeller nut	1	SUS304
9	Discharge bushing	1	SUS420J2
10	Deflector	1	FC200
11	Oil seal	1	NBR
12	O-ring	※3	NBR
13	Strainer	1	SUS304
14	Supporter ring	1	SUS403
15	Washer	1	SUS403
16	Through bolt	6	SS400
17	Air vent valve	1	C3604BD
18	Motor	1	ADC
19	Terminal box	1	ADC (※4)
20	Main shaft	1	S35C

※1 Special polyamide resin reinforced with glass fiber, etc.

※2 2.2kW: 2, 3.0kW: 1, 4.0kW: 0

※3 2.2kW: 10, 3.0kW: 12, 4.0kW: 14

※4 Terminal box cover is SECE.

Note 1) The materials in the table above are equivalents.

Note 2) Structure and other details are subject to change without notice.



Features

- ① Energy-saving pump equipped with a Top Runner efficiency (equivalent to IE3) motor (VKB-e).
- ② Non-seal (mechanical seal-less) structure is adopted.
- ③ EU RoHs Directive (RoHS 6 restricted substances) compliant.
- ④ EU Directive for CE marking compliant.
- ⑤ The lineup includes the models that meet the efficiency standards of various regulations:  
VKB-e type : Equipped with a Top Runner efficiency (equivalent to IE3) motor.
- ⑥ Enhanced protection against mist and other environmental elements are available.
- ⑦ Impeller designed for high-frequency operation is adopted.
- ⑧ Capable of energy-saving operation with the inverter (flow rate adjusting, etc.) (200V class) \*2.
- ⑨ The lineup that includes both VKB-H type (pressure type) and VKB-Q type (flow rate type) broadens the scope of choices of heads and flow rates.



Please note that the paint color, etc. of the actual unit may partially differ from the photo.

Description of types

VKB 19 26 2 A H -e

- ①
- ②
- ③
- ④
- ⑤
- ⑥
- ⑦

- ① Model
- ② Number of impellers
- ③ Number of stages
- ④ Series number
- ⑤ Frequency A: 50/60Hz
- ⑥ Characteristics H: Pressure type  
Q: Flow rate type
- ⑦ Motor efficiency Top Runner efficiency equivalent to IE3

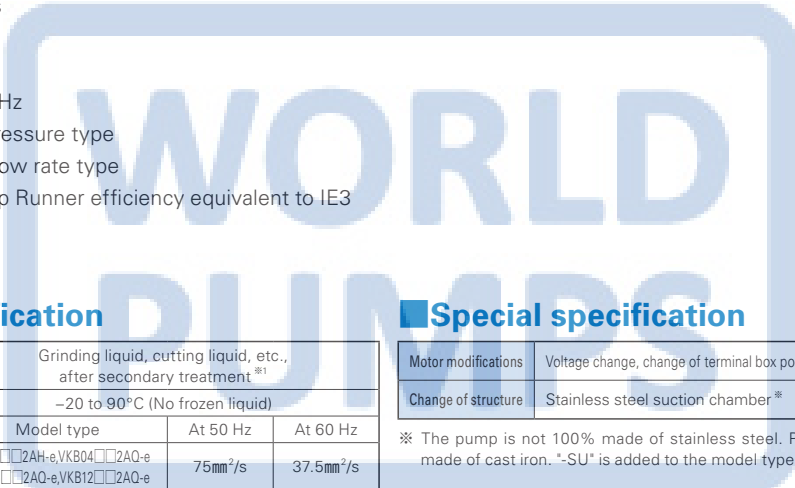

Standard Specification

Used liquid	Property of liquid	Grinding liquid, cutting liquid, etc., after secondary treatment *1		
	Temperature	-20 to 90°C (No frozen liquid)		
	Allowable kinematic viscosity	Model type	At 50 Hz	At 60 Hz
		VKB07□□2AH-e, VKB04□□2AQ-e VKB06□□2AQ-e, VKB12□□2AQ-e	75mm <sup>2</sup> /s	37.5mm <sup>2</sup> /s
VKB □□□□2F □ -e (50 Hz exclusive unit)		1mm <sup>2</sup> /s	—	
	Models other than the above	75mm <sup>2</sup> /s	75mm <sup>2</sup> /s	
Installation location		Indoor Ambient temperature: -20 to 40 °C, RH 85% or below (no condensation), Height above sea level : 1000m or less, Place not exposed to direct sunlight, Place in an area free of corrosive or explosive gas or vapor.		
Material	Pump leg	FC200		
	Casing·Outer casing	SUS304		
	Suction chamber	FC150		
	Impeller	SUS304		
	Main shaft (motor side + pump side)	S35C+SUS316		
Shaft seal structure		Non-seal (mechanical seal-less)		
Motor	Type	Totally enclosed fan-cooled type, indoor type		
	Protection method	IP54		
	Power source	A: 3-phase 50/60/60Hz 200/200/220V F: 3-phase 50Hz 200V		
	Thermal class	F		
	Number of poles	2P		
	Standard	IEC60034-1 CE Marking		
Paint color	Pump	Munsell N1		
	Motor	Black		

Special specification

Motor modifications	Voltage change, change of terminal box position, change of terminal box direction
Change of structure	Stainless steel suction chamber*

\* The pump is not 100% made of stainless steel. Pump legs and companion flanges are made of cast iron. \*-SU\* is added to the model type as a suffix.

Table of Consumable Parts

Type	Bearings		Oil seal			O-ring (Companion flange) Material: FKM		
	Load side	Unload side	Load side (Pump part)	Load side (Bearing part)	Unload side			
VKB05□□2FH-e ~ VKB07□□2FH-e	6305ZZC3	6203ZZC3	IS12257	DS17355	VC24406	G50		
VKB04□□2FQ-e								
VKB05□□2AH-e ~ VKB09□□2AH-e								
VKB08□□2FH-e ~ VKB19□□2FH-e	6307ZZC3	6303ZZC3						
VKB04□□2AQ-e ~ VKB06□□2AQ-e								
VKB05□□2FQ-e ~ VKB10□□2FQ-e								
VKB10□□2AH-e ~ VKB19□□2AH-e	6309ZZC3	6205ZZC3					VC25455	VC24406
VKB20□□2FH-e ~ VKB26□□2FH-e								
VKB07□□2AQ-e ~ VKB12□□2AQ-e								
VKB13□□2FQ-e ~ VKB22□□2FQ-e								

\*1 Take note that special liquid such as water, printing liquid or acid liquid cannot be used. Contact us for other special liquid (ceramic, etc.).

Selection chart

●VKB-H

(Values at kinematic viscosity 1mm<sup>2</sup>/s, specific gravity 1)

Synchronous rotating speed 50Hz : 3000min<sup>-1</sup>  
60Hz : 3600min<sup>-1</sup>

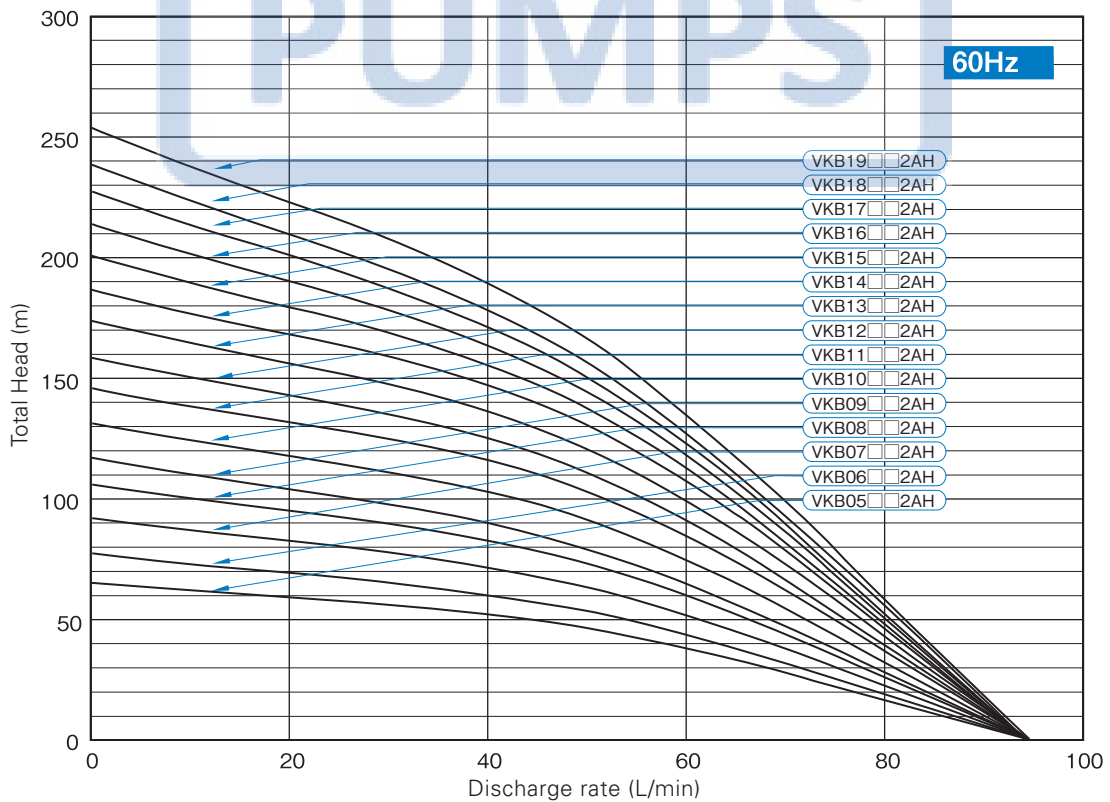
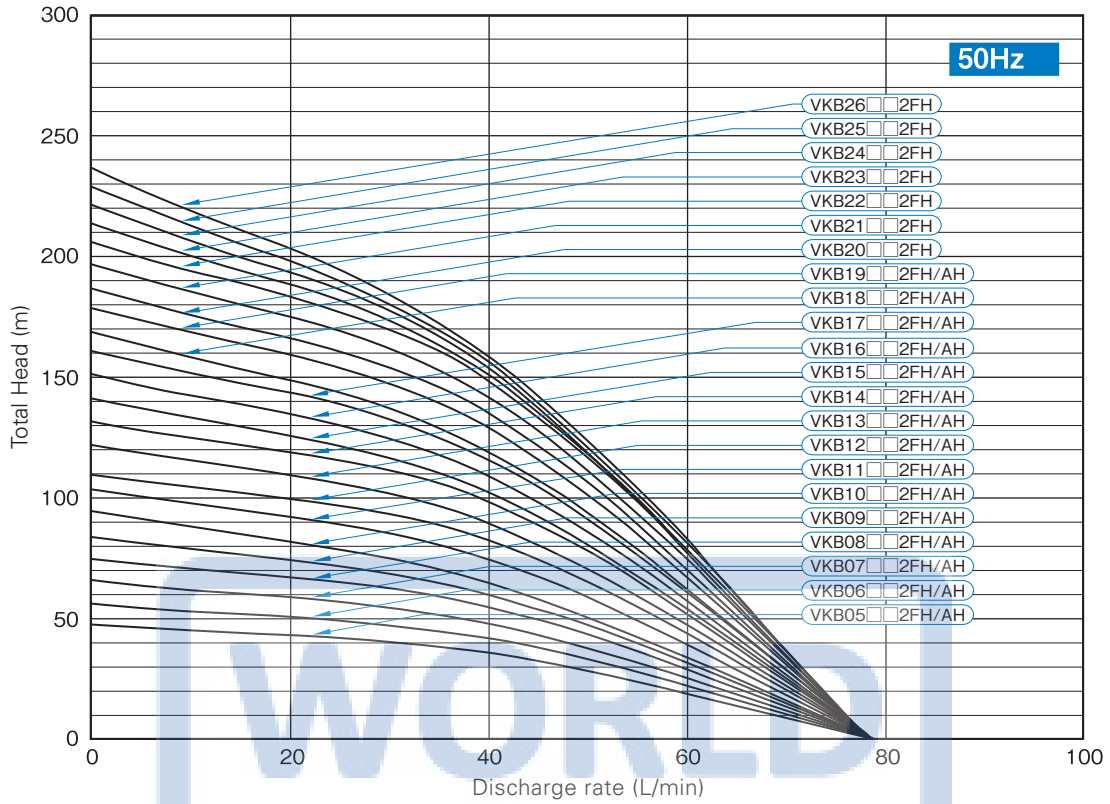

Note 1) The above characteristic curves reflect the full impeller condition of the units. The total head may be decreased depending on the flow rate if empty casings are involved because of pressure loss at the empty casings.

Note 2) Take note that discharge rate varies considerably depending on the type and kinematic viscosity of liquid. The above chart may not be used depending on the kinematic viscosity and specific gravity of the liquid.

Selection chart

●VKB-Q

(Values at kinematic viscosity 1mm<sup>2</sup>/s, specific gravity 1)

Synchronous rotating speed 50Hz : 3000min<sup>-1</sup>  
60Hz : 3600min<sup>-1</sup>

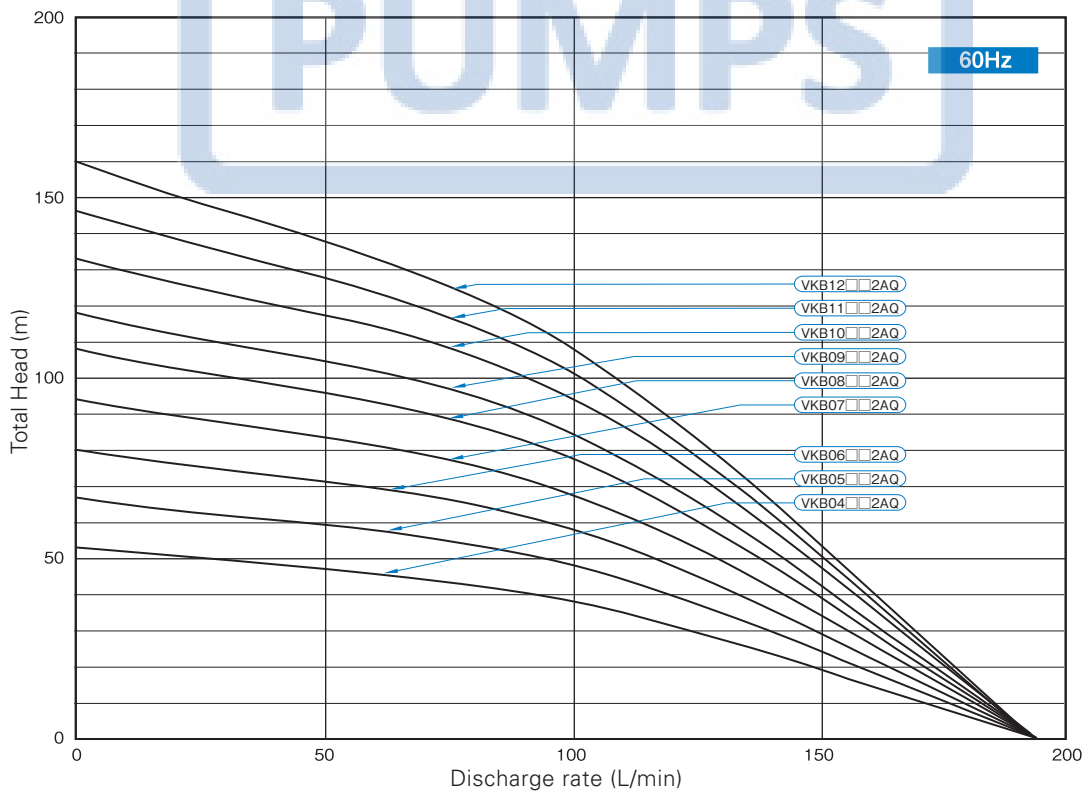
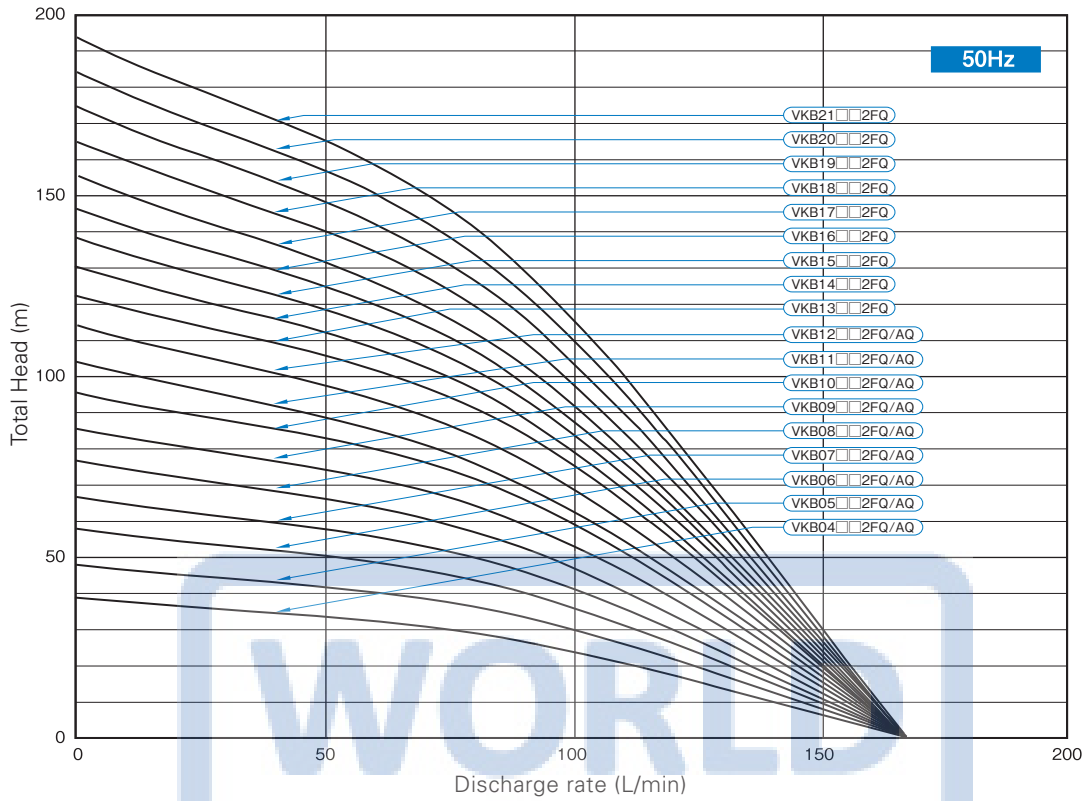

Note 1) The above characteristic curves reflect the full impeller condition of the units. The total head may be decreased depending on the flow rate if empty casings are involved because of pressure loss in the empty casings.

Note 2) Take note that discharge rate varies considerably depending on the type and kinematic viscosity of liquid. The above chart may not be used depending on the kinematic viscosity and specific gravity of the liquid.

## Specification table

### ● VKB-H

#### • VKB-AH-e

Type	50Hz							60Hz						
	Rated voltage (V)	Nominal output (kW)	Rated current (A)	Starting current (A)	Discharge rate (L/min)	Total head (m)	Allowable kinematic viscosity (mm <sup>2</sup> /s)	Rated voltage (V)	Nominal output (kW)	Rated current (A)	Starting current (A)	Discharge rate (L/min)	Total head (m)	Allowable kinematic viscosity (mm <sup>2</sup> /s)
VKB05□□2AH-e	200	0.5	5.4	56	40	30	75	200/220	0.85	5.8/5.6	55/60	50	40	75
VKB06□□2AH-e		0.6	5.9	56	40	36			1.02	6.0/5.8	55/60	50	48	
VKB07□□2AH-e		0.7	6.2	56	40	42			1.19	6.0/5.8	55/60	50	56	
VKB08□□2AH-e		0.8	6.9	84	40	48			1.36	8.8/8.3	73/80	50	64	75
VKB09□□2AH-e		0.9	7.4	84	40	54			1.53	10.0/9.1	73/80	50	72	
VKB10□□2AH-e		1	12.0	180	40	60			1.7	10.3/10.6	152/167	50	80	
VKB11□□2AH-e		1.1	12.3	180	40	66			1.87	11.1/11.3	152/167	50	88	
VKB12□□2AH-e		1.2	12.5	180	40	72			2.04	11.7/11.8	152/167	50	96	
VKB13□□2AH-e		1.3	12.9	180	40	78			2.21	12.7/12.6	152/167	50	104	
VKB14□□2AH-e		1.4	13.1	180	40	84			2.38	13.5/13.2	152/167	50	112	
VKB15□□2AH-e		1.5	13.6	180	40	90			2.55	14.4/13.9	152/167	50	120	
VKB16□□2AH-e		1.6	14.0	180	40	96			2.72	15.3/14.6	152/167	50	128	
VKB17□□2AH-e		1.7	14.5	180	40	102			2.89	16.2/15.3	152/167	50	136	
VKB18□□2AH-e		1.8	15.2	180	40	108			3.06	16.2/15.3	152/167	50	144	
VKB19□□2AH-e		1.9	15.7	180	40	114			3.23	16.2/15.3	152/167	50	152	

Note) The pump's rated current (current value listed on the pump nameplate) is the recommended current setting for protection device.

#### • VKB-FH-e

Type	50Hz						
	Rated voltage (V)	Nominal output (kW)	Rated current (A)	Starting current (A)	Discharge rate (L/min)	Total head (m)	Allowable kinematic viscosity (mm <sup>2</sup> /s)
VKB05□□2FH-e	200	0.5	3.6	30	40	30	1
VKB06□□2FH-e		0.6	4.0	30	40	36	
VKB07□□2FH-e		0.7	4.4	30	40	42	
VKB08□□2FH-e		0.8	5.8	56	40	48	
VKB09□□2FH-e		0.9	6.3	56	40	54	
VKB10□□2FH-e		1	6.4	56	40	60	
VKB11□□2FH-e		1.1	6.9	84	40	66	
VKB12□□2FH-e		1.2	7.2	84	40	72	
VKB13□□2FH-e		1.3	7.6	84	40	78	
VKB14□□2FH-e		1.4	8.0	84	40	84	
VKB15□□2FH-e		1.5	8.5	84	40	90	
VKB16□□2FH-e		1.6	9.0	84	40	96	
VKB17□□2FH-e		1.7	9.4	84	40	102	
VKB18□□2FH-e		1.8	10.0	84	40	108	
VKB19□□2FH-e		1.9	10.5	84	40	114	
VKB20□□2FH-e		2	13.3	180	40	120	
VKB21□□2FH-e		2.1	13.5	180	40	126	
VKB22□□2FH-e		2.2	13.8	180	40	132	
VKB23□□2FH-e		2.3	14.1	180	40	138	
VKB24□□2FH-e		2.4	14.5	180	40	144	
VKB25□□2FH-e		2.5	14.9	180	40	150	
VKB26□□2FH-e		2.6	15.4	180	40	156	

Note 1) The 50 Hz exclusive units are for use with water-soluble coolant liquids (1mm<sup>2</sup>/s kinematic viscosity) only. Contact us when your applications involve oil-based coolant liquids.

Note 2) The pump's rated current (current value listed on the pump nameplate) is the recommended current setting for protection device.

●VKB-Q  
· VKB-AQ-e

Type	50Hz							60Hz						
	Rated voltage (V)	Nominal output (kW)	Rated current (A)	Starting current (A)	Discharge rate (L/min)	Total head (m)	Allowable kinematic viscosity (mm <sup>2</sup> /s)	Rated voltage (V)	Nominal output (kW)	Rated current (A)	Starting current (A)	Discharge rate (L/min)	Total head (m)	Allowable kinematic viscosity (mm <sup>2</sup> /s)
VKB04□□2AQ-e	200	0.72	6.0	56	85	26	75	200/220	1.2	6.0/5.8	55/60	100	36	37.5
VKB05□□2AQ-e		0.9	7.0	84	85	33			1.5	8.8/8.3	73/80	100	46	75
VKB06□□2AQ-e		1.08	7.8	84	85	39			1.8	10.0/9.1	73/80	100	54	37.5
VKB07□□2AQ-e		1.26	12.4	180	85	45			2.1	11.3/11.4	152/167	100	63	75
VKB08□□2AQ-e		1.44	12.9	180	85	52			2.4	12.7/12.6	152/167	100	72	
VKB09□□2AQ-e		1.62	13.6	180	85	58			2.7	14.0/13.5	152/167	100	81	
VKB10□□2AQ-e		1.8	14.3	180	85	65			3	15.5/14.8	152/167	100	90	
VKB11□□2AQ-e		1.98	15.3	180	85	71			3.3	16.2/15.3	152/167	100	99	37.5
VKB12□□2AQ-e		2.16	16.3	180	85	78			3.6	16.2/15.3	152/167	100	108	

Note) The pump's rated current (current value listed on the pump nameplate) is the recommended current setting for protection device.

· VKB-FQ-e

Type	50Hz						
	Rated voltage (V)	Nominal output (kW)	Rated current (A)	Starting current (A)	Discharge rate (L/min)	Total head (m)	Allowable kinematic viscosity (mm <sup>2</sup> /s)
VKB04□□2FQ-e	200	0.72	4.4	30	85	26	1
VKB05□□2FQ-e		0.9	6.0	56	85	33	
VKB06□□2FQ-e		1.08	6.4	56	85	39	
VKB07□□2FQ-e		1.26	6.8	84	85	45	
VKB08□□2FQ-e		1.44	7.6	84	85	52	
VKB09□□2FQ-e		1.62	8.4	84	85	58	
VKB10□□2FQ-e		1.8	9.2	84	85	65	
VKB13□□2FQ-e		2.34	13.7	180	85	84	
VKB14□□2FQ-e		2.52	14.2	180	85	91	
VKB15□□2FQ-e		2.7	14.8	180	85	97	
VKB16□□2FQ-e		2.88	15.6	180	85	104	
VKB17□□2FQ-e		3.06	16.3	180	85	110	
VKB18□□2FQ-e		3.24	16.9	180	85	117	
VKB19□□2FQ-e		3.42	17.4	180	85	123	
VKB20□□2FQ-e		3.6	17.4	180	85	130	
VKB21□□2FQ-e		3.78	17.4	180	85	136	

Note 1) The 50Hz exclusive units are for use with water-soluble coolant liquids (1mm<sup>2</sup>/s kinematic viscosity) only. Contact us when your applications involve oil-based coolant liquids.  
Note 2) The pump's rated current (current value listed on the pump nameplate) is the recommended current setting for protection device.

■ Assembly drawing

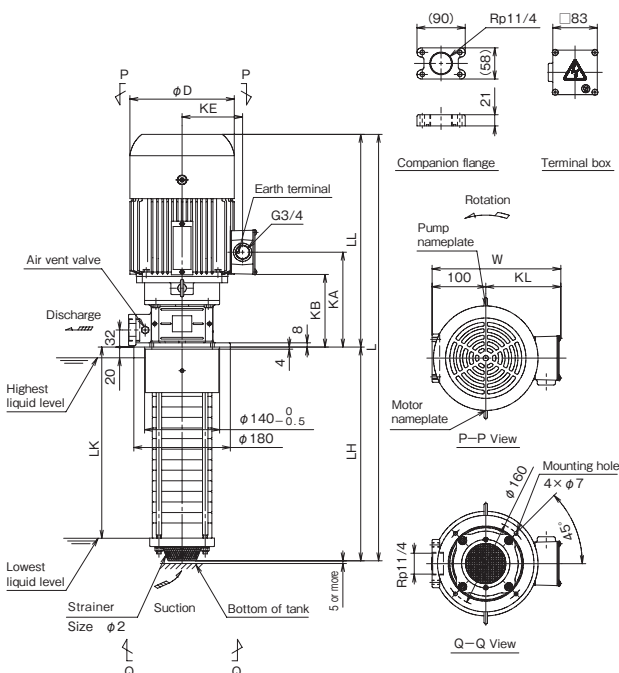

■ Detailed drawing of the terminal box

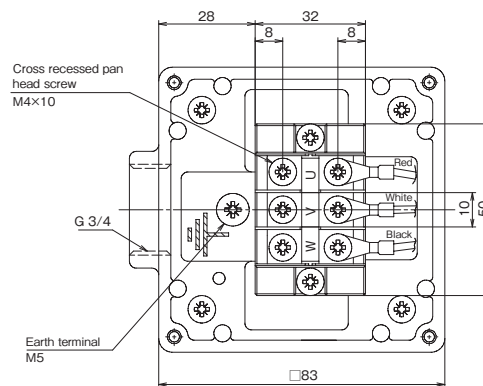

## Dimensions

### ●VKB-H

• VKB-AH-e

(Unit : mm)

Type	L	LH	LK	Approx.mass (kg)
VKB05102AH-e	632	300	258	25
VKB05112AH-e	652	320	278	25
VKB05132AH-e	692	360	318	25
VKB05152AH-e	731	399	357	26
VKB05172AH-e	770	438	396	26
VKB05182AH-e	790	458	416	26
VKB06102AH-e	632	300	258	25
VKB06112AH-e	652	320	278	25
VKB06132AH-e	692	360	318	25
VKB06152AH-e	731	399	357	26
VKB06172AH-e	770	438	396	26
VKB06182AH-e	790	458	416	26
VKB07102AH-e	632	300	258	25
VKB07112AH-e	652	320	278	25
VKB07132AH-e	692	360	318	25
VKB07152AH-e	731	399	357	26
VKB07172AH-e	770	438	396	26
VKB07182AH-e	790	458	416	26
VKB08102AH-e	657	300	258	30
VKB08112AH-e	677	320	278	30
VKB08132AH-e	717	360	318	30
VKB08152AH-e	756	399	357	31
VKB08172AH-e	795	438	396	31
VKB08182AH-e	815	458	416	31
VKB08212AH-e	874	517	475	32
VKB08222AH-e	894	537	495	32
VKB08262AH-e	973	616	574	33
VKB09102AH-e	657	300	258	30
VKB09112AH-e	677	320	278	30
VKB09132AH-e	717	360	318	30
VKB09152AH-e	756	399	357	31
VKB09172AH-e	795	438	396	31
VKB09182AH-e	815	458	416	32
VKB09212AH-e	874	517	475	32
VKB09222AH-e	894	537	495	32
VKB09262AH-e	973	616	574	33
VKB10102AH-e	697	300	258	37
VKB10112AH-e	717	320	278	37
VKB10132AH-e	757	360	318	38
VKB10152AH-e	796	399	357	38
VKB10172AH-e	835	438	396	39
VKB10182AH-e	855	458	416	39
VKB10212AH-e	914	517	475	39
VKB10222AH-e	934	537	495	40
VKB10262AH-e	1013	616	574	41
VKB11112AH-e	717	320	278	37
VKB11132AH-e	757	360	318	38
VKB11152AH-e	796	399	357	38
VKB11172AH-e	835	438	396	39
VKB11182AH-e	855	458	416	39
VKB11212AH-e	914	517	475	39
VKB11222AH-e	934	537	495	40
VKB11262AH-e	1013	616	574	41

(Unit : mm)

Type	L	LH	LK	Approx.mass (kg)
VKB12122AH-e	737	340	298	38
VKB12132AH-e	757	360	318	38
VKB12152AH-e	796	399	357	38
VKB12172AH-e	835	438	396	39
VKB12182AH-e	855	458	416	39
VKB12202AH-e	894	497	455	39
VKB12222AH-e	934	537	495	40
VKB12262AH-e	1013	616	574	41
VKB13132AH-e	757	360	318	38
VKB13152AH-e	796	399	357	38
VKB13182AH-e	855	458	416	39
VKB13202AH-e	894	497	455	39
VKB13222AH-e	934	537	495	40
VKB13262AH-e	1013	616	574	41
VKB14142AH-e	776	379	337	38
VKB14152AH-e	796	399	357	38
VKB14182AH-e	855	458	416	39
VKB14192AH-e	875	478	436	39
VKB14202AH-e	894	497	455	39
VKB14222AH-e	934	537	495	40
VKB14262AH-e	1013	616	574	41
VKB15152AH-e	796	399	357	38
VKB15182AH-e	855	458	416	39
VKB15202AH-e	894	497	455	40
VKB15222AH-e	934	537	495	40
VKB15262AH-e	1013	616	574	41
VKB16162AH-e	816	419	377	39
VKB16182AH-e	855	458	416	39
VKB16202AH-e	894	497	455	40
VKB16222AH-e	934	537	495	40
VKB16262AH-e	1013	616	574	41
VKB17172AH-e	835	438	396	39
VKB17182AH-e	855	458	416	39
VKB17202AH-e	894	497	455	40
VKB17212AH-e	914	517	475	40
VKB17222AH-e	934	537	495	40
VKB17262AH-e	1013	616	574	41
VKB18182AH-e	855	458	416	39
VKB18202AH-e	894	497	455	40
VKB18212AH-e	914	517	475	40
VKB18222AH-e	934	537	495	40
VKB18242AH-e	973	576	534	41
VKB18252AH-e	993	596	554	41
VKB18262AH-e	1013	616	574	41
VKB19212AH-e	914	517	475	40
VKB19262AH-e	1013	616	574	41

(Unit : mm)

Number of impellers	D	KA	KB	KE	KL	LL	W
05~07	157	167	125	95	122	332	222
08~09	175	167	125	103	130	357	230
10~19	195	177	135	113	140	397	240

・VKB-FH-e

(Unit : mm)

Type	L	LH	LK	Approx.mass (kg)
VKB05102FH-e	612	300	258	21
VKB05112FH-e	632	320	278	20
VKB05132FH-e	672	360	318	21
VKB05152FH-e	711	399	357	21
VKB05182FH-e	770	458	416	22
VKB06102FH-e	612	300	258	21
VKB06112FH-e	632	320	278	21
VKB06132FH-e	672	360	318	21
VKB06152FH-e	711	399	357	21
VKB06182FH-e	770	458	416	22
VKB07102FH-e	612	300	258	21
VKB07112FH-e	632	320	278	21
VKB07132FH-e	672	360	318	21
VKB07152FH-e	711	399	357	22
VKB07172FH-e	750	438	396	22
VKB07182FH-e	770	458	416	22
VKB07222FH-e	849	537	495	23
VKB07262FH-e	928	616	574	24
VKB08102FH-e	632	300	258	25
VKB08112FH-e	652	320	278	25
VKB08132FH-e	692	360	318	25
VKB08152FH-e	731	399	357	26
VKB08172FH-e	770	438	396	26
VKB08182FH-e	790	458	416	27
VKB08212FH-e	849	517	475	27
VKB08222FH-e	869	537	495	27
VKB08262FH-e	948	616	574	28
VKB09102FH-e	632	300	258	25
VKB09112FH-e	652	320	278	25
VKB09132FH-e	692	360	318	26
VKB09152FH-e	731	399	357	26
VKB09172FH-e	770	438	396	26
VKB09182FH-e	790	458	416	27
VKB09212FH-e	849	517	475	27
VKB09222FH-e	869	537	495	28
VKB09262FH-e	948	616	574	28
VKB10102FH-e	632	300	258	25
VKB10112FH-e	652	320	278	25
VKB10132FH-e	692	360	318	26
VKB10152FH-e	731	399	357	26
VKB10172FH-e	770	438	396	26
VKB10182FH-e	790	458	416	27
VKB10212FH-e	849	517	475	27
VKB10222FH-e	869	537	495	28
VKB10262FH-e	948	616	574	28
VKB11112FH-e	677	320	278	30
VKB11132FH-e	717	360	318	31
VKB11152FH-e	756	399	357	31
VKB11172FH-e	795	438	396	31
VKB11182FH-e	815	458	416	32
VKB11212FH-e	874	517	475	32
VKB11222FH-e	894	537	495	33
VKB11262FH-e	973	616	574	33
VKB12122FH-e	697	340	298	30
VKB12132FH-e	717	360	318	31
VKB12152FH-e	756	399	357	31
VKB12172FH-e	795	438	396	32
VKB12182FH-e	815	458	416	32
VKB12212FH-e	854	497	455	32
VKB12222FH-e	894	537	495	33
VKB12262FH-e	973	616	574	34

(Unit : mm)

Type	L	LH	LK	Approx.mass (kg)
VKB13132FH-e	717	360	318	31
VKB13152FH-e	756	399	357	31
VKB13172FH-e	795	438	396	32
VKB13182FH-e	815	458	416	32
VKB13212FH-e	854	497	455	32
VKB13222FH-e	894	537	495	33
VKB13262FH-e	973	616	574	34
VKB14142FH-e	736	379	337	31
VKB14152FH-e	756	399	357	31
VKB14182FH-e	815	458	416	32
VKB14212FH-e	854	497	455	33
VKB14222FH-e	894	537	495	33
VKB14262FH-e	973	616	574	34
VKB15152FH-e	756	399	357	31
VKB15162FH-e	776	419	377	32
VKB15172FH-e	795	438	396	32
VKB15182FH-e	815	458	416	32
VKB15212FH-e	854	497	455	33
VKB15222FH-e	894	537	495	33
VKB15262FH-e	973	616	574	34
VKB16162FH-e	776	419	377	32
VKB16172FH-e	795	438	396	32
VKB16182FH-e	815	458	416	32
VKB16212FH-e	854	497	455	33
VKB16222FH-e	894	537	495	33
VKB16262FH-e	973	616	574	34
VKB17172FH-e	795	438	396	32
VKB17182FH-e	815	458	416	32
VKB17212FH-e	874	517	475	33
VKB17222FH-e	894	537	495	33
VKB17262FH-e	973	616	574	34
VKB18182FH-e	815	458	416	32
VKB18212FH-e	874	517	475	33
VKB18222FH-e	894	537	495	33
VKB18232FH-e	933	576	534	33
VKB18262FH-e	973	616	574	34
VKB19192FH-e	835	478	436	33
VKB19212FH-e	874	517	475	33
VKB19222FH-e	894	537	495	33
VKB19262FH-e	973	616	574	34
VKB20202FH-e	894	497	455	40
VKB20212FH-e	914	517	475	40
VKB20222FH-e	934	537	495	40
VKB20262FH-e	1013	616	574	41
VKB21212FH-e	914	517	475	40
VKB21222FH-e	934	537	495	41
VKB21262FH-e	1013	616	574	41
VKB22222FH-e	934	537	495	41
VKB22242FH-e	973	576	534	41
VKB22262FH-e	1013	616	574	41
VKB23232FH-e	953	556	514	41
VKB23262FH-e	1013	616	574	42
VKB24242FH-e	973	576	534	41
VKB24262FH-e	1013	616	574	42
VKB25252FH-e	993	596	554	41
VKB25262FH-e	1013	616	574	42
VKB26262FH-e	1013	616	574	42

(Unit : mm)

Number of impellers	D	KA	KB	KE	KL	LL	W
05~07	140	167	125	88	115	312	215
08~10	157	167	125	95	122	332	222
11~19	175	167	125	103	130	357	230
20~26	195	177	135	113	140	397	240

## ●VKB-Q

· VKB-AQ-e

(Unit : mm)

Type	L	LH	LK	Approx.mass (kg)
VKB04072AQ-e	623	291	249	24
VKB04082AQ-e	651	319	277	24
VKB04092AQ-e	679	347	305	24
VKB04102AQ-e	707	375	333	25
VKB04122AQ-e	763	431	389	25
VKB04142AQ-e	819	487	445	26
VKB04152AQ-e	847	515	473	26
VKB04162AQ-e	875	543	501	26
VKB04192AQ-e	959	627	585	27
VKB04222AQ-e	1043	711	669	28
VKB05072AQ-e	648	291	249	29
VKB05082AQ-e	676	319	277	29
VKB05092AQ-e	704	347	305	29
VKB05102AQ-e	732	375	333	30
VKB05122AQ-e	788	431	389	30
VKB05142AQ-e	844	487	445	31
VKB05152AQ-e	872	515	473	31
VKB05162AQ-e	900	543	501	31
VKB05192AQ-e	984	627	585	32
VKB05222AQ-e	1068	711	669	33
VKB06072AQ-e	648	291	249	29
VKB06082AQ-e	676	319	277	29
VKB06092AQ-e	704	347	305	30
VKB06102AQ-e	732	375	333	30
VKB06122AQ-e	788	431	389	30
VKB06142AQ-e	844	487	445	31
VKB06152AQ-e	872	515	473	31
VKB06162AQ-e	900	543	501	31
VKB06192AQ-e	984	627	585	32
VKB06222AQ-e	1068	711	669	33
VKB07072AQ-e	688	291	249	36
VKB07082AQ-e	716	319	277	37
VKB07092AQ-e	744	347	305	37
VKB07102AQ-e	772	375	333	37
VKB07122AQ-e	828	431	389	37
VKB07142AQ-e	884	487	445	38
VKB07152AQ-e	912	515	473	38
VKB07162AQ-e	940	543	501	38
VKB07192AQ-e	1024	627	585	39

(Unit : mm)

Type	L	LH	LK	Approx.mass (kg)
VKB07222AQ-e	1108	711	669	40
VKB08082AQ-e	716	319	277	37
VKB08092AQ-e	744	347	305	37
VKB08102AQ-e	772	375	333	37
VKB08122AQ-e	828	431	389	38
VKB08142AQ-e	884	487	445	38
VKB08152AQ-e	912	515	473	38
VKB08162AQ-e	940	543	501	39
VKB08192AQ-e	1024	627	585	39
VKB08222AQ-e	1108	711	669	40
VKB09092AQ-e	744	347	305	37
VKB09102AQ-e	772	375	333	37
VKB09122AQ-e	828	431	389	38
VKB09142AQ-e	884	487	445	38
VKB09152AQ-e	912	515	473	38
VKB09162AQ-e	940	543	501	39
VKB09192AQ-e	1024	627	585	39
VKB09222AQ-e	1108	711	669	40
VKB10102AQ-e	772	375	333	37
VKB10122AQ-e	828	431	389	38
VKB10142AQ-e	884	487	445	38
VKB10152AQ-e	912	515	473	39
VKB10162AQ-e	940	543	501	39
VKB10192AQ-e	1024	627	585	39
VKB10222AQ-e	1108	711	669	40
VKB11112AQ-e	800	403	361	38
VKB11122AQ-e	828	431	389	38
VKB11142AQ-e	884	487	445	38
VKB11152AQ-e	912	515	473	39
VKB11162AQ-e	940	543	501	39
VKB11192AQ-e	1024	627	585	40
VKB11222AQ-e	1108	711	669	40
VKB12122AQ-e	828	431	389	38
VKB12142AQ-e	884	487	445	38
VKB12152AQ-e	912	515	473	39
VKB12162AQ-e	940	543	501	39
VKB12192AQ-e	1024	627	585	40
VKB12222AQ-e	1108	711	669	40

(Unit : mm)

Number of impellers	D	KA	KB	KE	KL	LL	W
04	157	167	125	95	122	332	222
05~06	175	167	125	103	130	357	230
07~12	195	177	135	113	140	397	240



・VKB-FQ-e

(Unit : mm)

Type	L	LH	LK	Approx.mass (kg)
VKB04072FQ-e	603	291	249	20
VKB04082FQ-e	631	319	277	20
VKB04102FQ-e	687	375	333	20
VKB04122FQ-e	743	431	389	21
VKB04142FQ-e	799	487	445	21
VKB04162FQ-e	855	543	501	22
VKB04192FQ-e	939	627	585	23
VKB04222FQ-e	1023	711	669	23
VKB05072FQ-e	623	291	249	24
VKB05082FQ-e	651	319	277	24
VKB05102FQ-e	707	375	333	25
VKB05122FQ-e	763	431	389	25
VKB05142FQ-e	819	487	445	26
VKB05162FQ-e	875	543	501	26
VKB05192FQ-e	959	627	585	27
VKB05222FQ-e	1043	711	669	28
VKB06072FQ-e	623	291	249	24
VKB06082FQ-e	651	319	277	24
VKB06102FQ-e	707	375	333	25
VKB06122FQ-e	763	431	389	25
VKB06142FQ-e	819	487	445	26
VKB06162FQ-e	875	543	501	26
VKB06192FQ-e	959	627	585	27
VKB06222FQ-e	1043	711	669	28
VKB07072FQ-e	648	291	249	29
VKB07082FQ-e	676	319	277	29
VKB07102FQ-e	732	375	333	30
VKB07122FQ-e	788	431	389	30
VKB07142FQ-e	844	487	445	31
VKB07162FQ-e	900	543	501	31
VKB07192FQ-e	984	627	585	32
VKB07222FQ-e	1068	711	669	33
VKB08082FQ-e	676	319	277	30
VKB08102FQ-e	732	375	333	30
VKB08122FQ-e	788	431	389	30
VKB08142FQ-e	844	487	445	31
VKB08162FQ-e	900	543	501	31
VKB08192FQ-e	984	627	585	32
VKB08222FQ-e	1068	711	669	33
VKB09092FQ-e	704	347	305	30
VKB09102FQ-e	732	375	333	30

(Unit : mm)

Type	L	LH	LK	Approx.mass (kg)
VKB09122FQ-e	788	431	389	31
VKB09142FQ-e	844	487	445	31
VKB09162FQ-e	900	543	501	32
VKB09192FQ-e	984	627	585	32
VKB09222FQ-e	1068	711	669	33
VKB10102FQ-e	732	375	333	30
VKB10122FQ-e	788	431	389	31
VKB10142FQ-e	844	487	445	31
VKB10162FQ-e	900	543	501	32
VKB10192FQ-e	1012	655	613	32
VKB10222FQ-e	1068	711	669	33
VKB13132FQ-e	856	459	417	38
VKB13142FQ-e	884	487	445	39
VKB13162FQ-e	940	543	501	39
VKB13192FQ-e	1024	627	585	40
VKB13202FQ-e	1052	655	613	40
VKB13222FQ-e	1108	711	669	41
VKB14142FQ-e	884	487	445	39
VKB14162FQ-e	940	543	501	39
VKB14192FQ-e	1024	627	585	40
VKB14222FQ-e	1108	711	669	41
VKB15152FQ-e	912	515	473	39
VKB15162FQ-e	940	543	501	39
VKB15192FQ-e	1024	627	585	40
VKB15222FQ-e	1108	711	669	41
VKB16162FQ-e	940	543	501	39
VKB16192FQ-e	1024	627	585	40
VKB16222FQ-e	1108	711	669	41
VKB17172FQ-e	968	571	529	40
VKB17192FQ-e	1024	627	585	40
VKB17222FQ-e	1108	711	669	41
VKB18182FQ-e	996	599	557	40
VKB18192FQ-e	1024	627	585	40
VKB18222FQ-e	1108	711	669	41
VKB19192FQ-e	1024	627	585	40
VKB19222FQ-e	1108	711	669	41
VKB20202FQ-e	1052	655	613	41
VKB20222FQ-e	1108	711	669	41
VKB21212FQ-e	1080	683	641	41
VKB21222FQ-e	1108	711	669	41

(Unit : mm)

Number of impellers	D	KA	KB	KE	KL	LL	W
04	140	167	125	88	115	312	215
05~06	157	167	125	95	122	332	222
07~10	175	167	125	103	130	357	230
13~21	195	177	135	113	140	397	240

Sectional drawing

●VKB-H

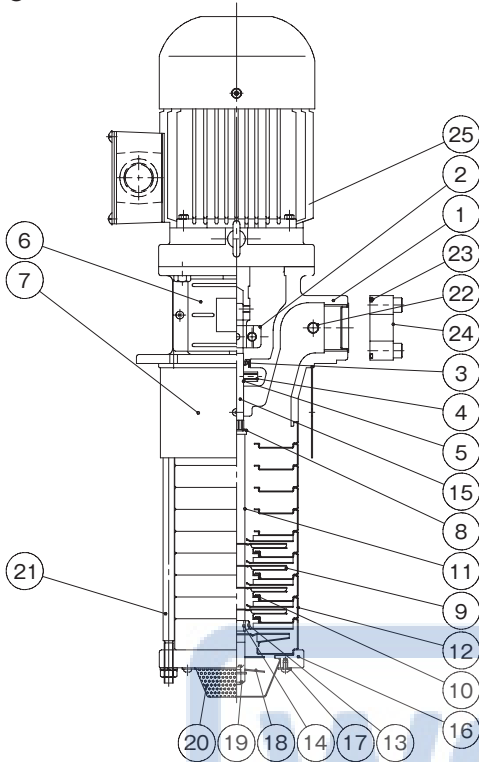

No.	Part name	Material
1	Pump leg	FC200
2	Coupling	S45C
3	Oil seal	NBR
4	Oil thrower	SUS304
5	O-ring	FKM
6	Coupling guard	SUS304
7	Outer casing	SUS304
8	Washer	SUS403
9	Impeller	SUS304
10	Seal ring	PTFE
11	Collar	SUS304
12	Casing	SUS304
13	Bearing ring	CERAMIC
14	Sleeve	WC
15	Main shaft (motor side+pump side)	S35C+SUS316
16	Suction chamber	FC200
17	Strainer retainer plate	SUS304
18	Screw	SUS304
19	U-nut	SUS304
20	Wide strainer	SUS304
21	Fastening bolt	SUS304
22	Air vent valve	BRASS
23	O-ring	FKM
24	Companion flange	FC150
25	Motor	—

Note 1) The materials in the table above are equivalents.  
Note 2) Structure and other details are subject to change without notice.

●VKB-Q

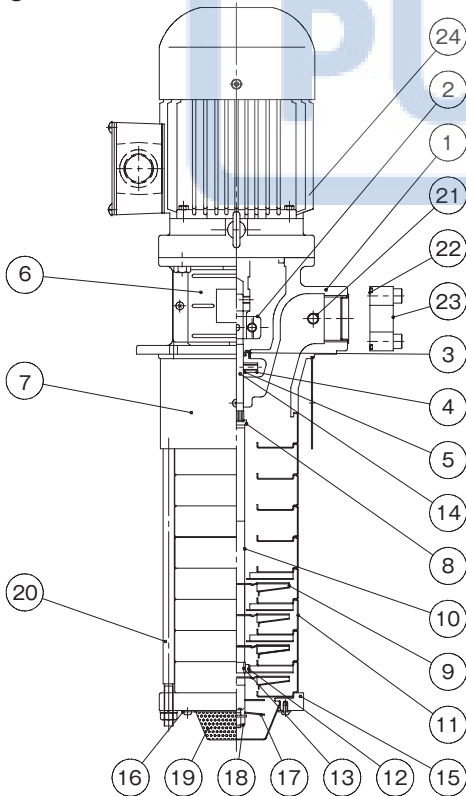

No.	Part name	Material
1	Pump leg	FC200
2	Coupling	S45C
3	Oil seal	NBR
4	Oil thrower	SUS304
5	O-ring	FKM
6	Coupling guard	SUS304
7	Outer casing	SUS304
8	Washer	SUS403
9	Impeller	SUS304
10	Collar	SUS304
11	Casing	SUS304
12	Bearing ring	CERAMIC
13	Sleeve	WC
14	Main shaft (motor side+pump side)	S35C+SUS316
15	Suction chamber	FC200
16	Strainer retainer plate	SUS304
17	Screw	SUS304
18	U-nut	SUS304
19	Wide strainer	SUS304
20	Fastening bolt	SUS304
21	Air vent valve	BRASS
22	O-ring	FKM
23	Companion flange	FC150
24	Motor	—

Note 1) The materials in the table above are equivalents.  
Note 2) Structure and other details are subject to change without notice.

Features

- ① Energy-saving pump equipped with a Top Runner efficiency (equivalent to IE3) motor.
- ② Non-seal (mechanical seal-less) structure is adopted.
- ③ Stainless steel is used in the pump's main liquid contact part and SiC bearings with increased wear resistance are adopted.
- ④ Measures against air suction into the pump are taken when the fluid level lowers.
- ⑤ EU RoHS Directive (RoHS 6 restricted substances) compliant.  
Output range for standard specification: 0.75 to 7.5kW. (Special specification to be taken for output range of 11kW or more.)
- ⑥ EU Directive for CE marking compliant.
- ⑦ Energy saving by high efficiency impeller!  
Power consumption decreases by 20% compared to conventional models!
- ⑧ Diverse lineup offers a wider choice according to your applications:  
Discharge rate 50Hz: 10 to 500L/min, 60Hz: 10 to 600L/min  
Total head 50Hz: Maximum 230m, 60Hz: Maximum 260m  
Output: 0.75 to 18.5kW  
(0.75 to 7.5kW is NEMA Premium motor)
- ⑨ The connecting dimensions are compatible with those of conventional pumps.

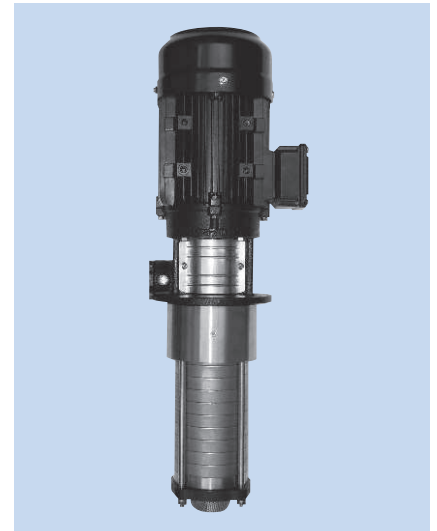

Please note that the paint color, etc. of the actual unit may partially differ from the photo.

Non-seal structure

TERAL's original "non-seal" structure allows coolant to flow from a narrow clearance without using a seal between the pump section and the motor section.

The advantages of a non-seal pump

- 1 No trouble such as coolant leaks.**  
Helps cut down on running costs.
- 2 Prevents air entrainment.**  
Reduces initial problems.
- 3 Not easily affected by a small quantity of liquid or shut-off operations.**  
Enables a flexible operation system.

※What is non-seal structure?

This structure inwardly releases coolant by depressurizing through a narrow clearance without the use of a mechanical seal.

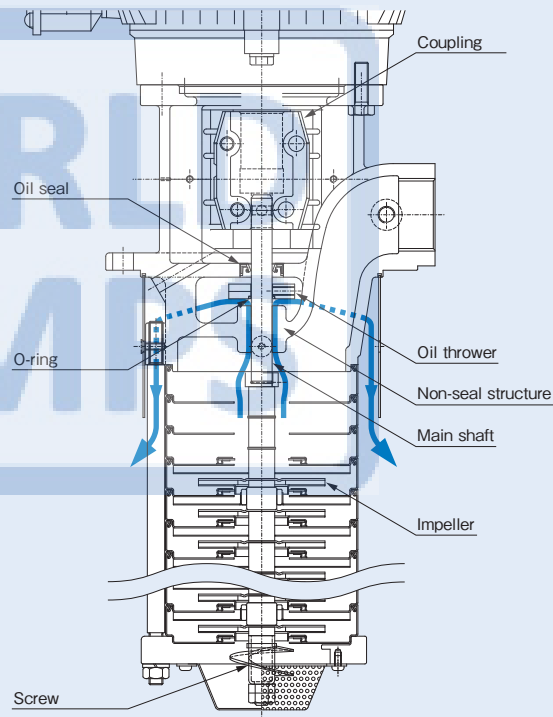

Description of types

**50 LVS 10 - 20 / 12 - 6 7.5 -e**

- ①    ②    ③    ④    ⑤    ⑥    ⑦    ⑧

- ① Discharge diameter
- ② Model
- ③ Nominal flow rate (m<sup>3</sup>/h)
- ④ Number of casings
- ⑤ Number of impellers
- ⑥ Frequency 5:50Hz  
6:60Hz
- ⑦ Output
- ⑧ Motor efficiency Top Runner efficiency (equivalent to IE3).

Standard Specification

Used liquid	Property of liquid	Water soluble coolants (e.g. grinding liquid, cutting liquid after secondary treatment) <sup>※1</sup>
	Temperature	0 to 90°C (No frozen liquid)
	Allowable kinematic viscosity	1mm <sup>2</sup> /s
Installation location		Indoor Ambient temperature: 0 to 40°C, RH 85% or below (no condensation), Height above sea level : 1000m or less, Place not exposed to direct sunlight, Place in an area free of corrosive or explosive gas or vapor.
Material	Suction/Discharge casing	FC200
	Intermediate casing	SUS304
	Impeller	SUS304
	Main shaft	SUS420J2
Shaft seal structure		Non-seal (mechanical seal-less)
Motor	Type	Totally enclosed fan-cooled outdoor type <sup>※2</sup>
	Protection method	IP55
	Power source	3-phase 50/60/60Hz, 200/200/230V 0.75~7.5kW 3-phase 50/60/60Hz, 200/200/220V 11~18.5kW
	Thermal class	F
	Number of poles	2P
	Standard	IEC60034-1
Paint color	Pump	Munsell N1
	Motor	Black

※1 If the liquid contains hard sludge, such as abrasive powder, ground powder, or ground diamond grains, the service life might be shortened. Please set up a filter (magnet filter or paper filter, etc.). Take note that water cannot be used. Contact us for other special liquid (pure water, alkali-acid liquid, ceramic, etc.).

※2 The pump cannot be installed outside.

Special specification

Special accessory

Motor modifications	Voltage change <sup>※1</sup> , change of terminal box position <sup>※2</sup> , change of terminal box direction <sup>※3</sup>
Change of structure	Stainless steel suction casing <sup>※4</sup>

Companion flange (discharge diameter 32 mm)
---

- ※1 7.5kW or less (50Hz/380V,400V 60Hz/400V 460V)  
11kW or more(50Hz/380V,400V,415V,420V,440V 60Hz/400V,440V,460V,480V)
- ※2 Change of terminal box position (every 90° when viewed from above)
- ※3 Terminal box direction (every 90° when viewed from front), Applicable: 1.5 kW to 18.5 kW
- ※4 "-SU" is appended to the end of model type.

Note: The pump is not 100% made of stainless steel. Discharge casings and companion flanges are made of cast iron.

Table of Consumable Parts

Output (kW)	Bearing		Oil seal				O-ring (For oil thrower) Material: FKM		
	Load side	Unload side	Motor		Discharge casing		Bore diameter 32	Bore diameter 50	
			Load side (Bearing side)	Unload side	Bore diameter 32	Bore diameter 50			
0.75	6204ZCC3	6201ZCC3	—	—	IS12257	SC16328	S12	S16	
1.1		6304ZCC3	6305ZCC3	—					VC20407
1.5	VC25407			VC25477					
2.2									
3.0	6307ZCC3			6305ZCC3					
4.0		VC45628							
5.5	7309B	6309ZCC3	Please contact us						
7.5									
11									
15									
18.5									

Selection chart

(Values at kinematic viscosity 1mm<sup>2</sup>/s, specific gravity 1)

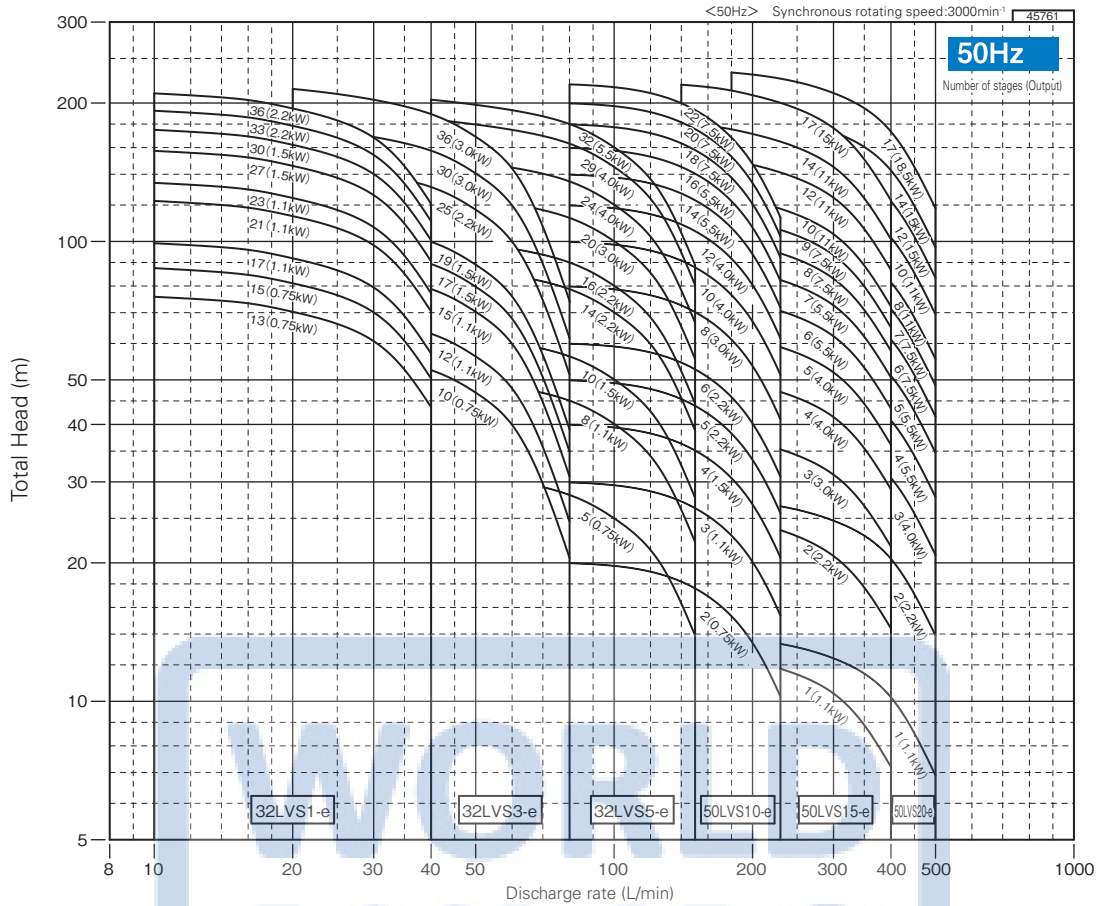

Note 1) The above selection chart reflects the full impeller condition of the units. The total head may be decreased depending on the flow rate if empty casings are involved because of pressure loss in the empty casings.

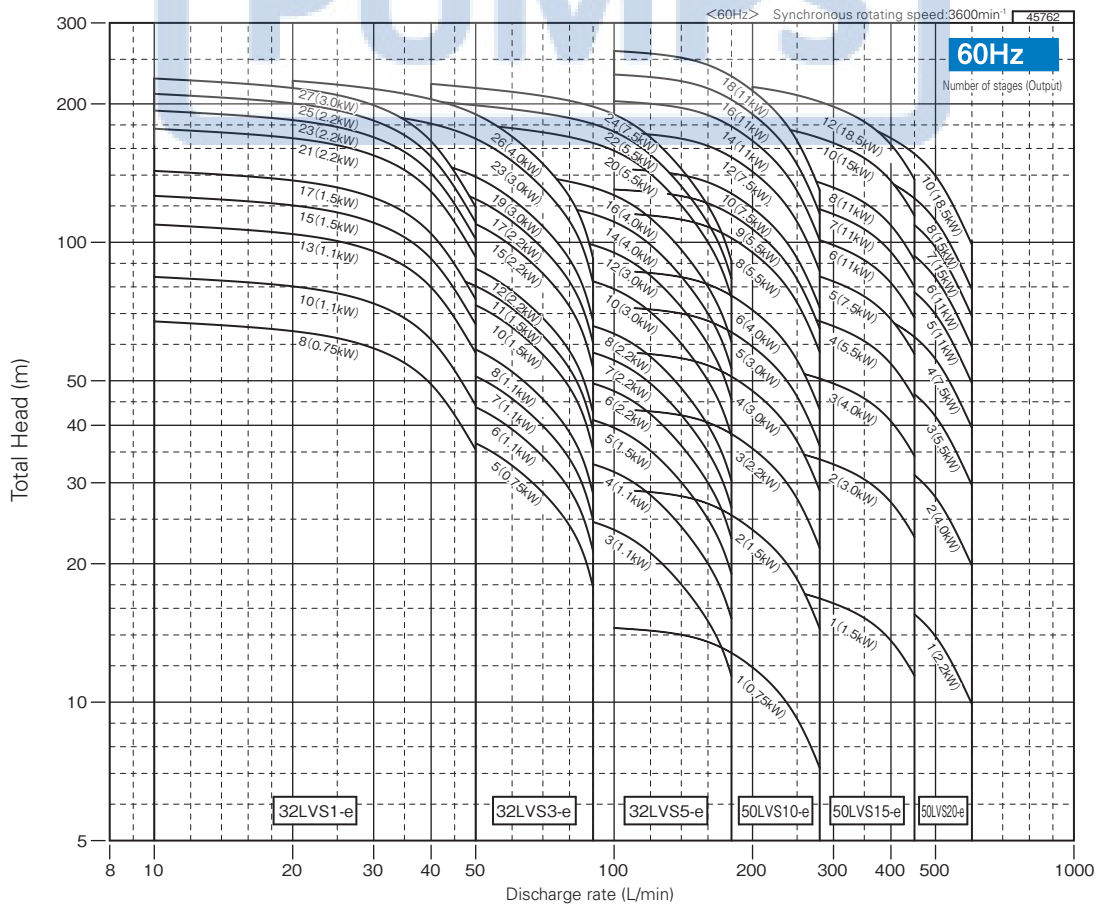

Note 1) The above selection chart reflects the full impeller condition of the units. The total head may be decreased depending on the flow rate if empty casings are involved because of pressure loss in the empty casings.

## Pressure loss in the empty casings (50 Hz/60 Hz)

Pressure loss for 1 stage of empty casing is as follows:

LVS1-e

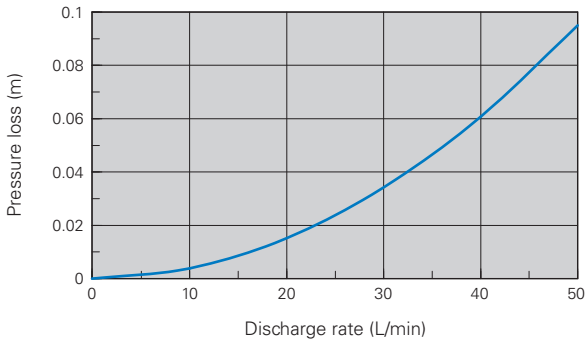

LVS10-e

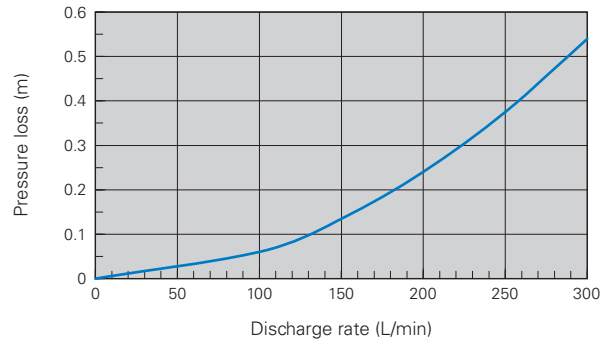

LVS3-e

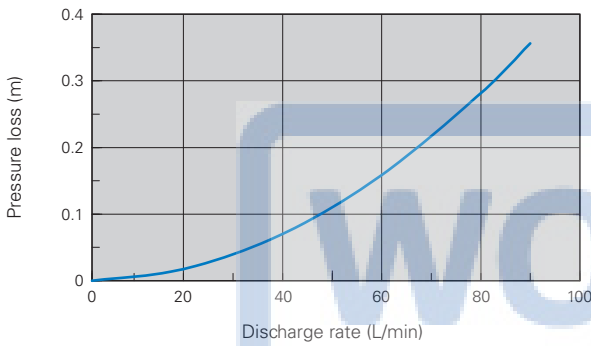

LVS15-e

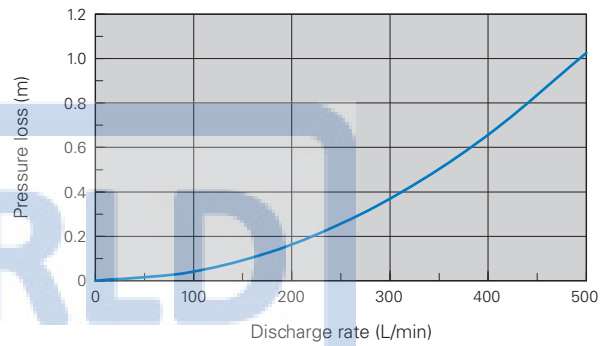

LVS5-e

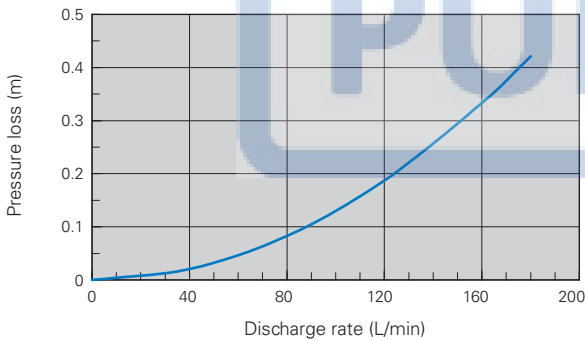

LVS20-e

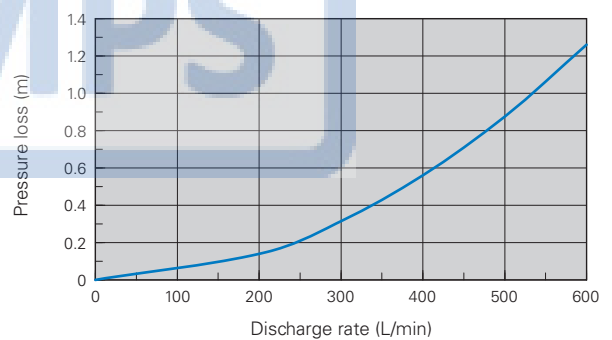

The selection chart is a performance chart of the full-impeller model (all casings are equipped with impeller). A pump with empty casings (without impeller) will have some influence on the total head of the pump depending on the flow rate due to its pressure loss.

The pressure loss per 1 stage of empty casing of each model is as shown in the graph above.

In the case of a pump with many stages of empty casings, the maximum flow rate may slightly decrease.

For details, refer to the characteristic curve chart.

### ● Calculation example of total pump head in consideration of pressure loss of empty casing

- Pump type : 32LVS5-20/5-5.75-e
- Specification flow rate: 100L/min
- Specification total head: 20m
- The number of stages: 20
- Number of impellers: 5

From the graph above, the pressure loss per 1 stage of empty casing is 0.13 m for a flow rate of 100L/min

The number of stages of the empty casing is 20 - 5 = 15 stages.

Total pressure loss =  $0.13 \times 15 \approx 2.0\text{m}$

From the selection chart, the total head is 25 m for a flow rate of 100L/min.

The pressure loss is subtracted from the total head.

Total head =  $25 - 2.0 = 23.0\text{m}$

Therefore, the total head of 32LVS5-20/5-5.75-e is 23.0 m for a flow rate of 100 L/min.

Specification table

50Hz

Bore diameter (mm)	Frequency (m³/h)	Type	Output (kW)	Rated voltage (V)	Rated current (A)	Starting current (A)	Discharge rate (L/min)	Total Head (m)	
32	1	32LVS1-□/13-5.75-e	0.75	200	3.4	26	10~40	75.5 ~ 43.5	
		32LVS1-□/15-5.75-e						87 ~ 50	
		32LVS1-□/17-51.1-e	1.1		4.7	34		99 ~ 56.5	
		32LVS1-□/21-51.1-e						122 ~ 70	
		32LVS1-□/23-51.1-e	1.5		6.2	47		134 ~ 77	
		32LVS1-□/27-51.5-e						157 ~ 90	
		32LVS1-□/30-51.5-e	2.2		8.7	83		174.5 ~ 100.5	
		32LVS1-□/33-52.2-e						192 ~ 110.5	
	32LVS1-36/36-52.2-e					209.5 ~ 120.5			
	3	3	32LVS3-□/10-5.75-e		0.75	3.4	26	20~80	59.5 ~ 20.5
			32LVS3-□/12-51.1-e		1.1	4.7	34		71.5 ~ 24.5
			32LVS3-□/15-51.1-e		1.5	6.2	47		89 ~ 30.5
			32LVS3-□/17-51.5-e						101 ~ 34.5
			32LVS3-□/19-51.5-e		2.2	8.7	83		113 ~ 38.5
			32LVS3-□/25-52.2-e						149 ~ 51
			32LVS3-□/30-53.0-e		3.0	12.2	129		178.5 ~ 61.5
			32LVS3-36/36-53.0-e						214.5 ~ 73.5
	5	5	32LVS5-□/5-5.75-e		0.75	3.4	26	40~150	31.5 ~ 13.5
			32LVS5-□/8-51.1-e		1.1	4.7	34		50.5 ~ 22
			32LVS5-□/10-51.5-e		1.5	6.2	47		63 ~ 27.5
			32LVS5-□/14-52.2-e		2.2	8.7	83		88.5 ~ 38.5
			32LVS5-□/16-52.2-e		3.0	12.2	129		101 ~ 44
			32LVS5-□/20-53.0-e						126.5 ~ 55
			32LVS5-□/24-54.0-e		4.0	14.7	145		152 ~ 66.5
			32LVS5-□/29-54.0-e		5.5	20.3	204		183.5 ~ 80
	32LVS5-32/32-55.5-e	202.5 ~ 88.5							
	50	10	50LVS10-□/2-5.75-e		0.75	3.4	26	80~230	19.5 ~ 9
			50LVS10-□/3-51.1-e		1.1	4.7	34		29.5 ~ 15
50LVS10-□/4-51.5-e			1.5	6.2	47	39.5 ~ 20.5			
50LVS10-□/5-52.2-e			2.2	8.7	83	49.5 ~ 26			
50LVS10-□/6-52.2-e						59.5 ~ 31			
50LVS10-□/8-53.0-e			3.0	12.2	129	79.5 ~ 41.5			
50LVS10-□/10-54.0-e			4.0	14.7	145	99.5 ~ 52			
50LVS10-□/12-54.0-e						119.5 ~ 62.5			
50LVS10-□/14-55.5-e			5.5	20.3	204	139.5 ~ 73			
50LVS10-□/16-55.5-e						159.5 ~ 83.5			
50LVS10-□/18-57.5-e			7.5	27.2	290	179.5 ~ 94			
50LVS10-□/20-57.5-e						199.5 ~ 104.5			
50LVS10-22/22-57.5-e					219 ~ 114.5				
15		15	50LVS15-□/1-51.1-e	1.1	4.7	34	140~400	12.5 ~ 5.5	
			50LVS15-□/2-52.2-e	2.2	8.7	83		25.5 ~ 13.5	
			50LVS15-□/3-53.0-e	3.0	12.2	129		38.5 ~ 21.5	
			50LVS15-□/4-54.0-e	4.0	14.7	145		51.5 ~ 28.5	
			50LVS15-□/5-54.0-e					64.5 ~ 36	
			50LVS15-□/6-55.5-e	5.5	20.3	204		77 ~ 43	
			50LVS15-□/7-55.5-e					90 ~ 50.5	
			50LVS15-□/8-57.5-e	7.5	27.2	290		103 ~ 57.5	
			50LVS15-□/9-57.5-e					116 ~ 65	
			50LVS15-□/10-511-e	11	40.5	361		129 ~ 72	
			50LVS15-□/12-511-e					154.5 ~ 86.5	
			50LVS15-□/14-511-e	15	54.0	484		180.5 ~ 101	
50LVS15-17/17-515-e		219 ~ 122.5							
20		20	50LVS20-□/1-51.1-e	1.1	4.7	34	180~500	13 ~ 5	
			50LVS20-□/2-52.2-e	2.2	8.7	83		27 ~ 13	
			50LVS20-□/3-54.0-e	4.0	14.7	145		41 ~ 20.5	
			50LVS20-□/4-55.5-e	5.5	20.3	204		54.5 ~ 27.5	
			50LVS20-□/5-55.5-e					68.5 ~ 34.5	
			50LVS20-□/6-57.5-e	7.5	27.2	290		82 ~ 41.5	
	50LVS20-□/7-57.5-e		95.5 ~ 48.5						
	50LVS20-□/8-511-e		11	40.5	361	109.5 ~ 55.5			
	50LVS20-□/10-511-e					137 ~ 69			
	50LVS20-□/12-515-e		15	54.0	484	163 ~ 83			
	50LVS20-□/14-515-e					191.5 ~ 97			
	50LVS20-17/17-518-e		18.5	66.0	563	232.5 ~ 117.5			

Note) The rated current in the table above is the recommended setting for the current value of the protective device.

## Specification table

## 60Hz

Bore diameter (mm)	Frequency (m <sup>3</sup> /h)	Type	Output (kW)	Rated voltage (V)	Rated current (A)	Starting current (A)	Discharge rate (L/min)	Total Head (m)	
32	1	32LVS1-□/8-6.75-e	0.75	200/230	3.2/3.1	25.0/28.5	10~50	67 ~ 35	
		32LVS1-□/10-61.1-e	1.1		4.4/4.1	32.5/37.0		84 ~ 44	
		32LVS1-□/13-61.1-e			1.5	5.9/5.4		41.0/47.6	109 ~ 57
		32LVS1-□/15-61.5-e	2.2			8.4/7.6		78.0/82.6	126 ~ 66
		32LVS1-□/17-61.5-e			3.0	11.5/10.8		115/135	142.5 ~ 75
		32LVS1-□/21-62.2-e	4.0			14.3/12.8		132/151	176.5 ~ 92.5
		32LVS1-□/23-62.2-e			5.5	19.8/17.8		178/206	193 ~ 101.5
		32LVS1-□/25-62.2-e	7.5			26.5/23.7		254/295	210 ~ 110.5
	32LVS1-□/27-63.0-e	11			38.3/34.8	296/333	227 ~ 119		
	32LVS3-□/5-6.75-e		0.75		200/230	3.2/3.1	25.0/28.5	20~90	43 ~ 17.5
	32LVS3-□/6-61.1-e	1.1	4.4/4.1			32.5/37.0	51.5 ~ 21		
	32LVS3-□/7-61.1-e		1.5			5.9/5.4	41.0/47.6		60 ~ 24.5
	32LVS3-□/8-61.1-e	2.2				8.4/7.6	78.0/82.6		69 ~ 28
	32LVS3-□/10-61.5-e		3.0			11.5/10.8	115/135		86 ~ 35.5
	32LVS3-□/11-61.5-e	4.0				14.3/12.8	132/151		94.5 ~ 39
	32LVS3-□/12-62.2-e		5.5			19.8/17.8	178/206		103.5 ~ 42.5
	32LVS3-□/15-62.2-e	7.5				26.5/23.7	254/295		129.5 ~ 53
	32LVS3-□/17-62.2-e		11			38.3/34.8	296/333	146.5 ~ 60	
	32LVS3-□/19-63.0-e	15				53.0/49.0	397/447	164 ~ 67	
	32LVS3-□/23-63.0-e		18.5			65.0/59.0	456/515	198.5 ~ 81.5	
	32LVS3-□/26-64.0-e	22				84.0/76.6	78.0/82.6	224.5 ~ 92	
	32LVS5-□/3-61.1-e		1.1			200/230	4.4/4.1	32.5/37.0	40~180
	32LVS5-□/4-61.1-e	1.5	5.9/5.4				41.0/47.6	36.5 ~ 15	
	32LVS5-□/5-61.5-e		2.2				8.4/7.6	78.0/82.6	
	32LVS5-□/6-62.2-e	3.0					11.5/10.8	115/135	
	32LVS5-□/7-62.2-e		4.0				14.3/12.8	132/151	
	32LVS5-□/8-62.2-e	5.5					19.8/17.8	178/206	
	32LVS5-□/10-63.0-e		7.5				26.5/23.7	254/295	
	32LVS5-□/12-63.0-e	11					38.3/34.8	296/333	
	32LVS5-□/14-64.0-e		15				53.0/49.0	397/447	128.5 ~ 53
	32LVS5-□/16-64.0-e	18.5					65.0/59.0	456/515	147 ~ 60.5
	32LVS5-□/20-65.5-e		22				84.0/76.6	78.0/82.6	184 ~ 75.5
32LVS5-□/22-65.5-e	26	108.0/100.0		118.0/110.0			202.5 ~ 83		
32LVS5-□/24-67.5-e		30	132.0/124.0	142.0/134.0			221 ~ 90.5		
50LVS10-□/1-6.75-e	0.75		200/220	3.2/3.1			25.0/28.5	100~280	14 ~ 5
50LVS10-□/2-61.5-e	1.5	5.9/5.4		41.0/47.6			28.5 ~ 13		
50LVS10-□/3-62.2-e		2.2		8.4/7.6			78.0/82.6		43 ~ 21
50LVS10-□/4-63.0-e	3.0			11.5/10.8			115/135		57.5 ~ 28.5
50LVS10-□/5-63.0-e		4.0		14.3/12.8			132/151		72 ~ 36.5
50LVS10-□/6-64.0-e	5.5			19.8/17.8			178/206		86.5 ~ 44
50LVS10-□/8-65.5-e		7.5		26.5/23.7			254/295		115.5 ~ 58.5
50LVS10-□/9-65.5-e	11			38.3/34.8	296/333		130 ~ 66		
50LVS10-□/10-67.5-e		15		53.0/49.0	397/447		144.5 ~ 73		
50LVS10-□/12-67.5-e	18.5			65.0/59.0	456/515		173.5 ~ 88		
50LVS10-□/14-611-e		22		84.0/76.6	78.0/82.6		202.5 ~ 102.5		
50LVS10-□/16-611-e	26			108.0/100.0	118.0/110.0		231.5 ~ 117		
50LVS10-□/18-611-e		30		132.0/124.0	142.0/134.0		260.5 ~ 132		
50LVS15-□/1-61.5-e	1.5			200/230	5.9/5.4		41.0/47.6	160~450	18 ~ 9.5
50LVS15-□/2-63.0-e	3.0	11.5/10.8			115/135		37 ~ 22		
50LVS15-□/3-64.0-e		4.0			14.3/12.8		132/151		55.5 ~ 34.5
50LVS15-□/4-65.5-e	5.5				19.8/17.8		178/206		74 ~ 46
50LVS15-□/5-67.5-e		7.5			26.5/23.7		254/295		92.5 ~ 57.5
50LVS15-□/6-611-e	11				38.3/34.8		296/333		111 ~ 69
50LVS15-□/7-611-e		15			53.0/49.0	397/447	130 ~ 81		
50LVS15-□/8-611-e	18.5				65.0/59.0	456/515	148.5 ~ 92.5		
50LVS15-□/10-615-e		22			84.0/76.6	78.0/82.6	185.5 ~ 115.5		
50LVS15-□/12-618-e	26				108.0/100.0	118.0/110.0	222.5 ~ 138.5		
50LVS20-□/1-62.2-e		2.2			200/230	8.4/7.6	78.0/82.6	220~600	19 ~ 7
50LVS20-□/2-64.0-e	4.0	14.3/12.8				132/151	39 ~ 18		
50LVS20-□/3-65.5-e		5.5				19.8/17.8	178/206		58.5 ~ 29.5
50LVS20-□/4-67.5-e	7.5					26.5/23.7	254/295		78 ~ 39.5
50LVS20-□/5-611-e		11				38.3/34.8	296/333		98 ~ 49
50LVS20-□/6-611-e	15					53.0/49.0	397/447		117.5 ~ 59
50LVS20-□/7-615-e		18.5				65.0/59.0	456/515		137 ~ 69
50LVS20-□/8-615-e	22					84.0/76.6	78.0/82.6		156.5 ~ 79
50LVS20-□/10-618-e		26				108.0/100.0	118.0/110.0	196 ~ 98.5	

Note) The rated current in the table above is the recommended setting for the current value of the protective device.



Assembly drawing

● Discharge diameter : 32mm

Fig.1

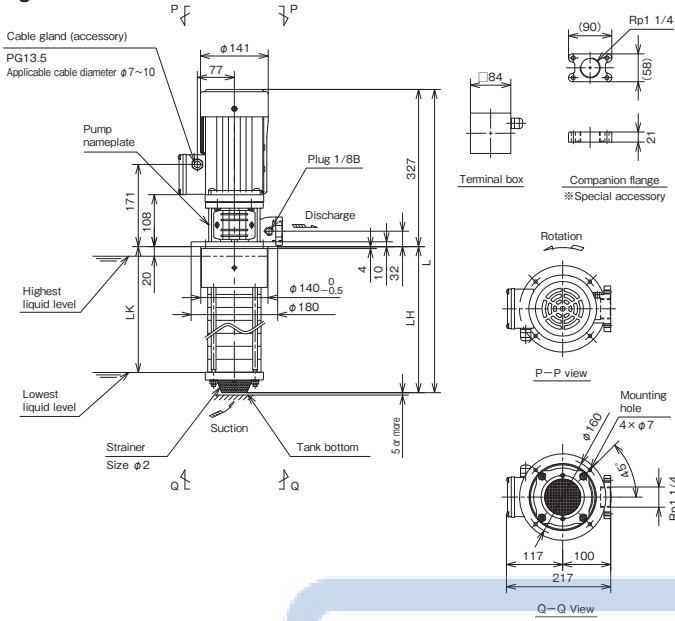
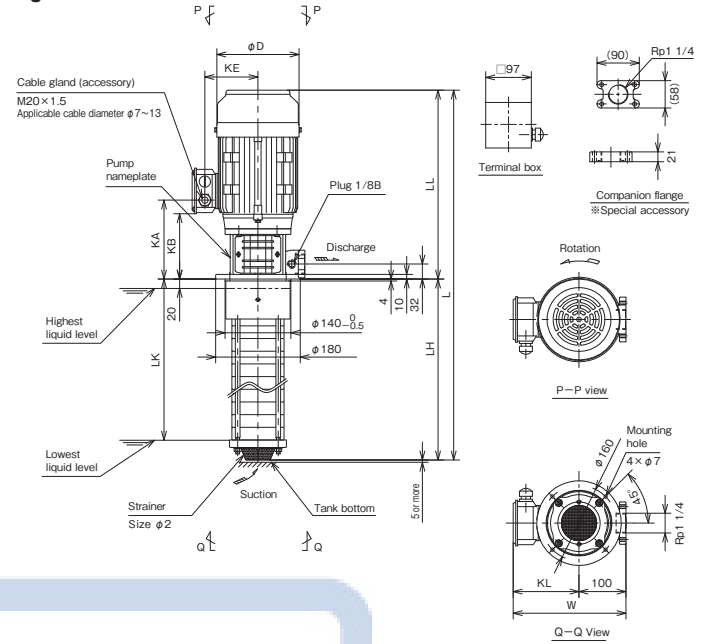

Fig.2



※ Output 0.75kW

(Unit : mm)

Output kW	D	KA	KB	KE	KL	LL	W
1.1	175	153	124	113	140	387	240
1.5/2.2	175	168	139	113	140	402	240
3.0	196	178	149	125	152	437	252
4.0	219	183	154	134	161	442	—

Fig.3

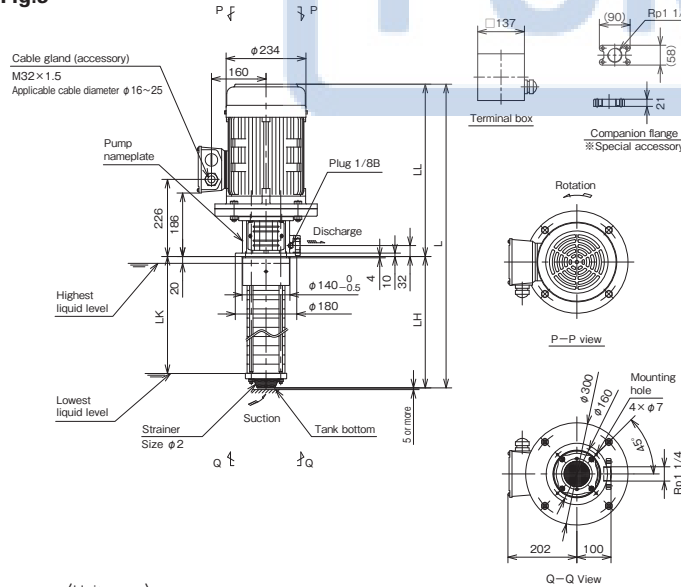

(Unit : mm)

Output kW	LL
5.5	505
7.5	540

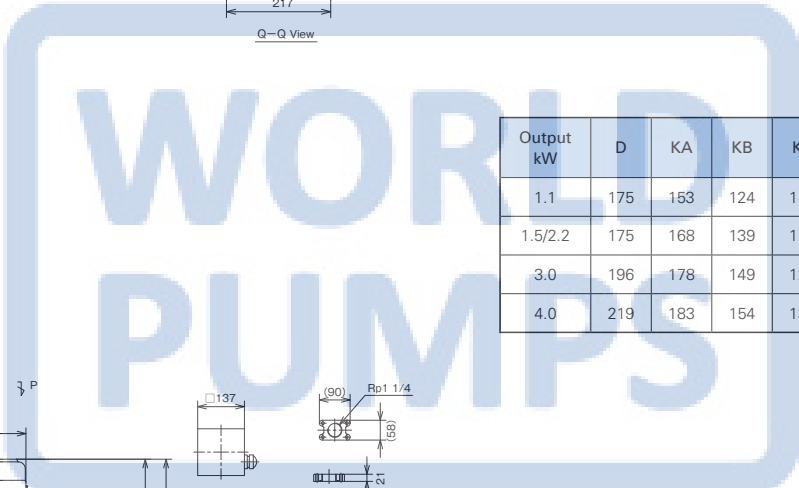

## Dimensions

● Discharge diameter : 32mm, Nominal flow rate : 1m<sup>3</sup>/h

50Hz

(Unit : mm)

Type	Fig.	L	LH	LK	Approx. mass(kg)
32LVS1-13/13-5.75-e	1	676	349	307	21
32LVS1-15/13-5.75-e		712	385	343	22
32LVS1-17/13-5.75-e		748	421	379	22
32LVS1-21/13-5.75-e		820	493	451	23
32LVS1-25/13-5.75-e		892	565	523	24
32LVS1-15/15-5.75-e		712	385	343	22
32LVS1-17/15-5.75-e		748	421	379	22
32LVS1-21/15-5.75-e		820	493	451	23
32LVS1-25/15-5.75-e		892	565	523	24
32LVS1-17/17-51.1-e		808	421	379	27
32LVS1-21/17-51.1-e	880	493	451	27	
32LVS1-25/17-51.1-e	952	565	523	28	
32LVS1-30/17-51.1-e	1042	655	613	30	
32LVS1-21/21-51.1-e	880	493	451	28	
32LVS1-25/21-51.1-e	952	565	523	29	
32LVS1-30/21-51.1-e	1042	655	613	30	
32LVS1-33/21-51.1-e	1096	709	667	30	
32LVS1-23/23-51.1-e	916	529	487	28	
32LVS1-25/23-51.1-e	952	565	523	29	
32LVS1-30/23-51.1-e	1042	655	613	30	
32LVS1-33/23-51.1-e	1096	709	667	31	
32LVS1-36/23-51.1-e	1150	763	721	31	
32LVS1-27/27-51.5-e	1003	601	559	34	
32LVS1-33/27-51.5-e	1111	709	667	35	
32LVS1-36/27-51.5-e	1165	763	721	36	
32LVS1-30/30-51.5-e	1057	655	613	34	
32LVS1-33/30-51.5-e	1111	709	667	35	
32LVS1-36/30-51.5-e	1165	763	721	36	
32LVS1-33/33-52.2-e	1111	709	667	39	
32LVS1-36/33-52.2-e	1165	763	721	39	
32LVS1-36/36-52.2-e	1165	763	721	39	

60Hz

(Unit : mm)

Type	Fig.	L	LH	LK	Approx. mass(kg)
32LVS1-8/8-6.75-e	1	586	259	217	20
32LVS1-10/8-6.75-e		622	295	253	20
32LVS1-13/8-6.75-e		676	349	307	21
32LVS1-15/8-6.75-e		712	385	343	22
32LVS1-17/8-6.75-e		748	421	379	22
32LVS1-21/8-6.75-e		820	493	451	23
32LVS1-25/8-6.75-e		892	565	523	24
32LVS1-10/10-61.1-e		682	295	253	25
32LVS1-13/10-61.1-e		736	349	307	25
32LVS1-15/10-61.1-e		772	385	343	26
32LVS1-17/10-61.1-e	808	421	379	26	
32LVS1-21/10-61.1-e	880	493	451	27	
32LVS1-25/10-61.1-e	952	565	523	28	
32LVS1-13/13-61.1-e	736	349	307	25	
32LVS1-15/13-61.1-e	772	385	343	26	
32LVS1-17/13-61.1-e	808	421	379	26	
32LVS1-21/13-61.1-e	880	493	451	27	
32LVS1-25/13-61.1-e	952	565	523	28	
32LVS1-15/15-61.5-e	787	385	343	30	
32LVS1-17/15-61.5-e	823	421	379	31	
32LVS1-21/15-61.5-e	895	493	451	31	
32LVS1-25/15-61.5-e	967	565	523	32	
32LVS1-30/15-61.5-e	1057	655	613	34	
32LVS1-17/17-61.5-e	823	421	379	31	
32LVS1-21/17-61.5-e	895	493	451	32	
32LVS1-25/17-61.5-e	967	565	523	33	
32LVS1-30/17-61.5-e	1057	655	613	34	
32LVS1-33/17-61.5-e	1111	709	667	34	
32LVS1-21/21-62.2-e	895	493	451	35	
32LVS1-25/21-62.2-e	967	565	523	36	
32LVS1-30/21-62.2-e	1057	655	613	37	
32LVS1-33/21-62.2-e	1111	709	667	38	
32LVS1-36/21-62.2-e	1165	763	721	39	
32LVS1-23/23-62.2-e	931	529	487	36	
32LVS1-27/23-62.2-e	1003	601	559	37	
32LVS1-30/23-62.2-e	1057	655	613	37	
32LVS1-33/23-62.2-e	1111	709	667	38	
32LVS1-36/23-62.2-e	1165	763	721	39	
32LVS1-25/25-62.2-e	967	565	523	36	
32LVS1-27/25-62.2-e	1003	601	559	37	
32LVS1-30/25-62.2-e	1057	655	613	38	
32LVS1-33/25-62.2-e	1111	709	667	38	
32LVS1-36/25-62.2-e	1165	763	721	39	
32LVS1-27/27-63.0-e	1038	601	559	45	
32LVS1-30/27-63.0-e	1092	655	613	46	
32LVS1-33/27-63.0-e	1146	709	667	46	
32LVS1-36/27-63.0-e	1200	763	721	47	

●Discharge diameter: 32mm, Nominal flow rate: 3m<sup>3</sup>/h

50Hz

(Unit : mm)

Type	Fig.	L	LH	LK	Approx. mass(kg)
32LVS3-10/10-5.75-e	1	622	295	253	20
32LVS3-12/10-5.75-e		658	331	289	21
32LVS3-15/10-5.75-e		712	385	343	22
32LVS3-19/10-5.75-e		784	457	415	23
32LVS3-23/10-5.75-e		856	529	487	23
32LVS3-12/12-51.1-e	2	718	331	289	25
32LVS3-15/12-51.1-e		772	385	343	26
32LVS3-19/12-51.1-e		844	457	415	27
32LVS3-23/12-51.1-e		916	529	487	28
32LVS3-15/15-51.1-e		772	385	343	26
32LVS3-19/15-51.1-e		844	457	415	27
32LVS3-23/15-51.1-e		916	529	487	28
32LVS3-17/17-51.5-e		823	421	379	31
32LVS3-23/17-51.5-e		931	529	487	32
32LVS3-26/17-51.5-e		985	583	541	33
32LVS3-19/19-51.5-e		859	457	415	31
32LVS3-23/19-51.5-e		931	529	487	32
32LVS3-26/19-51.5-e		985	583	541	33
32LVS3-30/19-51.5-e		1057	655	613	34
32LVS3-25/25-52.2-e		967	565	523	36
32LVS3-30/25-52.2-e		1057	655	613	38
32LVS3-36/25-52.2-e		1165	763	721	39
32LVS3-30/30-53.0-e		1092	655	613	46
32LVS3-36/30-53.0-e		1200	763	721	47
32LVS3-36/36-53.0-e		1200	763	721	47

60Hz

(Unit : mm)

Type	Fig.	L	LH	LK	Approx. mass(kg)	
32LVS3-5/5-6.75-e	1	532	205	163	19	
32LVS3-7/5-6.75-e		568	241	199	19	
32LVS3-10/5-6.75-e		622	295	253	20	
32LVS3-12/5-6.75-e		658	331	289	21	
32LVS3-15/5-6.75-e		712	385	343	21	
32LVS3-19/5-6.75-e		784	457	415	22	
32LVS3-23/5-6.75-e		856	529	487	23	
32LVS3-6/6-61.1-e		2	610	223	181	23
32LVS3-10/6-61.1-e			682	295	253	24
32LVS3-12/6-61.1-e			718	331	289	25
32LVS3-15/6-61.1-e			772	385	343	26
32LVS3-19/6-61.1-e			844	457	415	26
32LVS3-23/6-61.1-e			916	529	487	27
32LVS3-7/7-61.1-e			628	241	199	24
32LVS3-10/7-61.1-e			682	295	253	24
32LVS3-12/7-61.1-e	718		331	289	25	
32LVS3-15/7-61.1-e	772		385	343	26	
32LVS3-19/7-61.1-e	844		457	415	26	
32LVS3-23/7-61.1-e	916		529	487	27	
32LVS3-8/8-61.1-e	646		259	217	24	
32LVS3-10/8-61.1-e	682		295	253	24	
32LVS3-12/8-61.1-e	718		331	289	25	
32LVS3-15/8-61.1-e	772		385	343	26	
32LVS3-19/8-61.1-e	844		457	415	27	
32LVS3-23/8-61.1-e	916		529	487	27	
32LVS3-10/10-61.5-e	697		295	253	29	
32LVS3-12/10-61.5-e	733		331	289	29	
32LVS3-15/10-61.5-e	787	385	343	30		
32LVS3-19/10-61.5-e	859	457	415	31		
32LVS3-23/10-61.5-e	931	529	487	32		
32LVS3-11/11-61.5-e	715	313	271	29		
32LVS3-15/11-61.5-e	787	385	343	30		
32LVS3-19/11-61.5-e	859	457	415	31		
32LVS3-23/11-61.5-e	931	529	487	32		
32LVS3-12/12-62.2-e	733	331	289	33		
32LVS3-15/12-62.2-e	787	385	343	33		
32LVS3-19/12-62.2-e	859	457	415	34		
32LVS3-23/12-62.2-e	931	529	487	35		
32LVS3-15/15-62.2-e	787	385	343	34		
32LVS3-19/15-62.2-e	859	457	415	34		
32LVS3-23/15-62.2-e	931	529	487	35		
32LVS3-26/15-62.2-e	985	583	541	36		
32LVS3-17/17-62.2-e	823	421	379	34		
32LVS3-23/17-62.2-e	931	529	487	35		
32LVS3-26/17-62.2-e	985	583	541	36		
32LVS3-30/17-62.2-e	1057	655	613	37		
32LVS3-19/19-63.0-e	894	457	415	43		
32LVS3-23/19-63.0-e	966	529	487	43		
32LVS3-26/19-63.0-e	1020	583	541	44		
32LVS3-30/19-63.0-e	1092	655	613	45		
32LVS3-36/19-63.0-e	1200	763	721	46		
32LVS3-23/23-63.0-e	966	529	487	44		
32LVS3-26/23-63.0-e	1020	583	541	44		
32LVS3-30/23-63.0-e	1092	655	613	45		
32LVS3-36/23-63.0-e	1200	763	721	47		
32LVS3-26/26-64.0-e	1025	583	541	50		
32LVS3-30/26-64.0-e	1097	655	613	51		
32LVS3-36/26-64.0-e	1205	763	721	52		

●Discharge diameter: 32mm, Nominal flow rate: 5m<sup>3</sup>/h

50Hz

(Unit : mm)

Type	Fig.	L	LH	LK	Approx. mass(kg)
32LVS5-5/5-5.75-e	1	577	250	208	20
32LVS5-7/5-5.75-e		631	304	262	20
32LVS5-10/5-5.75-e		712	385	343	21
32LVS5-14/5-5.75-e		820	493	451	22
32LVS5-16/5-5.75-e		874	547	505	23
32LVS5-20/5-5.75-e		982	655	613	24
32LVS5-8/8-51.1-e	2	718	331	289	25
32LVS5-10/8-51.1-e		772	385	343	25
32LVS5-14/8-51.1-e		880	493	451	27
32LVS5-16/8-51.1-e		934	547	505	27
32LVS5-20/8-51.1-e		1042	655	613	29
32LVS5-10/10-51.5-e		787	385	343	30
32LVS5-14/10-51.5-e		895	493	451	31
32LVS5-16/10-51.5-e		949	547	505	32
32LVS5-20/10-51.5-e		1057	655	613	33
32LVS5-14/14-52.2-e		895	493	451	35
32LVS5-16/14-52.2-e		949	547	505	35
32LVS5-20/14-52.2-e		1057	655	613	37
32LVS5-24/14-52.2-e		1165	763	721	38
32LVS5-16/16-52.2-e		949	547	505	35
32LVS5-20/16-52.2-e		1057	655	613	37
32LVS5-24/16-52.2-e		1165	763	721	38
32LVS5-29/16-52.2-e		1300	898	856	39
32LVS5-20/20-53.0-e		1092	655	613	45
32LVS5-24/20-53.0-e		1200	763	721	46
32LVS5-29/20-53.0-e		1335	898	856	48
32LVS5-32/20-53.0-e		1416	979	937	49
32LVS5-24/24-54.0-e		1205	763	721	52
32LVS5-29/24-54.0-e		1340	898	856	53
32LVS5-32/24-54.0-e		1421	979	937	54
32LVS5-29/29-54.0-e	1340	898	856	53	
32LVS5-32/29-54.0-e	1421	979	937	54	
32LVS5-32/32-55.5-e	3	1484	979	937	82

60Hz

(Unit : mm)

Type	Fig.	L	LH	LK	Approx. mass(kg)
32LVS5-3/3-61.1-e	1	583	196	154	23
32LVS5-5/3-61.1-e		637	250	208	24
32LVS5-7/3-61.1-e		691	304	262	24
32LVS5-10/3-61.1-e		772	385	343	25
32LVS5-14/3-61.1-e		880	493	451	26
32LVS5-16/3-61.1-e		934	547	505	27
32LVS5-20/3-61.1-e		1042	655	613	28
32LVS5-4/4-61.1-e		610	223	181	23
32LVS5-6/4-61.1-e		664	277	235	24
32LVS5-8/4-61.1-e		718	331	289	24
32LVS5-10/4-61.1-e		772	385	343	25
32LVS5-14/4-61.1-e		880	493	451	27
32LVS5-16/4-61.1-e		934	547	505	28
32LVS5-20/4-61.1-e		1042	655	613	29
32LVS5-5/5-61.5-e		652	250	208	28
32LVS5-7/5-61.5-e		706	304	262	28
32LVS5-10/5-61.5-e		787	385	343	29
32LVS5-14/5-61.5-e		895	493	451	31
32LVS5-16/5-61.5-e		949	547	505	31
32LVS5-20/5-61.5-e		1057	655	613	33
32LVS5-6/6-62.2-e		679	277	235	32
32LVS5-8/6-62.2-e		733	331	289	32
32LVS5-10/6-62.2-e		787	385	343	33
32LVS5-14/6-62.2-e		895	493	451	34
32LVS5-16/6-62.2-e	949	547	505	35	
32LVS5-20/6-62.2-e	1057	655	613	36	
32LVS5-7/7-62.2-e	706	304	262	32	
32LVS5-10/7-62.2-e	787	385	343	33	
32LVS5-14/7-62.2-e	895	493	451	34	
32LVS5-16/7-62.2-e	949	547	505	35	
32LVS5-20/7-62.2-e	1057	655	613	36	
32LVS5-8/8-62.2-e	733	331	289	32	
32LVS5-10/8-62.2-e	787	385	343	33	
32LVS5-14/8-62.2-e	895	493	451	34	
32LVS5-16/8-62.2-e	949	547	505	35	
32LVS5-20/8-62.2-e	1057	655	613	36	
32LVS5-10/10-63.0-e	822	385	343	41	
32LVS5-14/10-63.0-e	930	493	451	42	
32LVS5-16/10-63.0-e	984	547	505	43	
32LVS5-20/10-63.0-e	1092	655	613	44	
32LVS5-12/12-63.0-e	876	439	397	42	
32LVS5-14/12-63.0-e	930	493	451	42	
32LVS5-16/12-63.0-e	984	547	505	43	
32LVS5-20/12-63.0-e	1092	655	613	44	
32LVS5-24/12-63.0-e	1200	763	721	45	
32LVS5-14/14-64.0-e	935	493	451	48	
32LVS5-16/14-64.0-e	989	547	505	49	
32LVS5-20/14-64.0-e	1097	655	613	50	
32LVS5-24/14-64.0-e	1205	763	721	51	
32LVS5-29/14-64.0-e	1340	898	856	53	
32LVS5-16/16-64.0-e	989	547	505	49	
32LVS5-20/16-64.0-e	1097	655	613	50	
32LVS5-24/16-64.0-e	1205	763	721	51	
32LVS5-29/16-64.0-e	1340	898	856	53	
32LVS5-32/16-64.0-e	1421	979	937	54	
32LVS5-20/20-65.5-e	3	1160	655	613	78
32LVS5-24/20-65.5-e		1268	763	721	79
32LVS5-29/20-65.5-e		1403	898	856	80
32LVS5-32/20-65.5-e		1484	979	937	81
32LVS5-22/22-65.5-e		1214	709	667	78
32LVS5-24/22-65.5-e		1268	763	721	79
32LVS5-29/22-65.5-e		1403	898	856	80
32LVS5-32/22-65.5-e		1484	979	937	81
32LVS5-24/24-67.5-e		1303	763	721	86
32LVS5-29/24-67.5-e		1438	898	856	87
32LVS5-32/24-67.5-e		1519	979	937	88

Assembly drawing

● Discharge diameter : 50mm

Fig.1

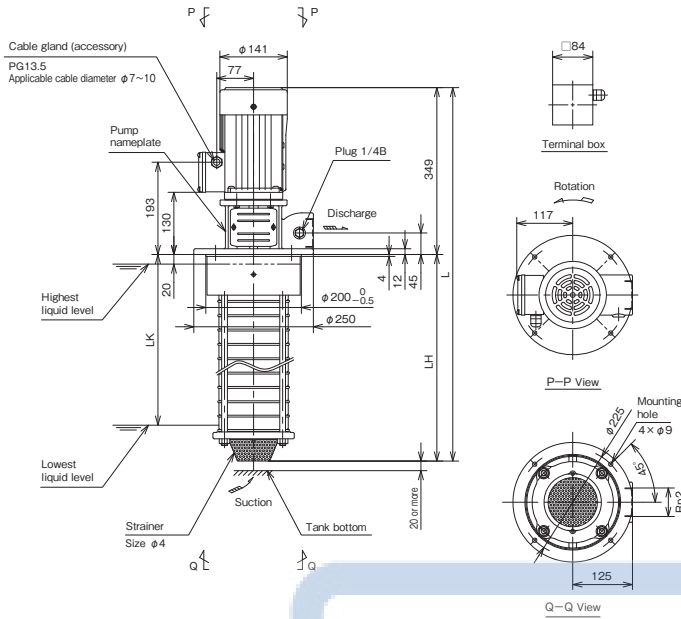

※ Output 0.75kW

Fig.2

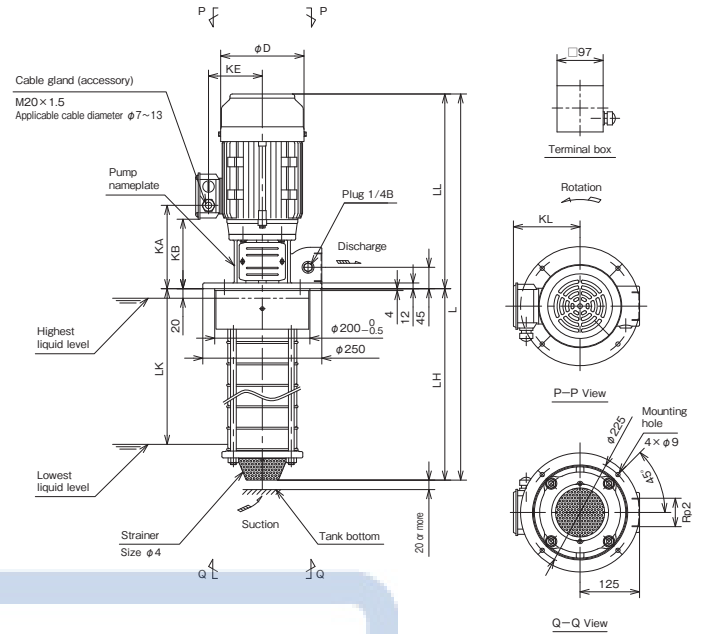

(Unit : mm)

Output kW	D	KA	KB	KE	KL	LL
1.1/1.5/2.2	175	175	146	113	140	409
3.0	196	185	156	125	152	462
4.0	219	190	161	134	161	449

Fig.3

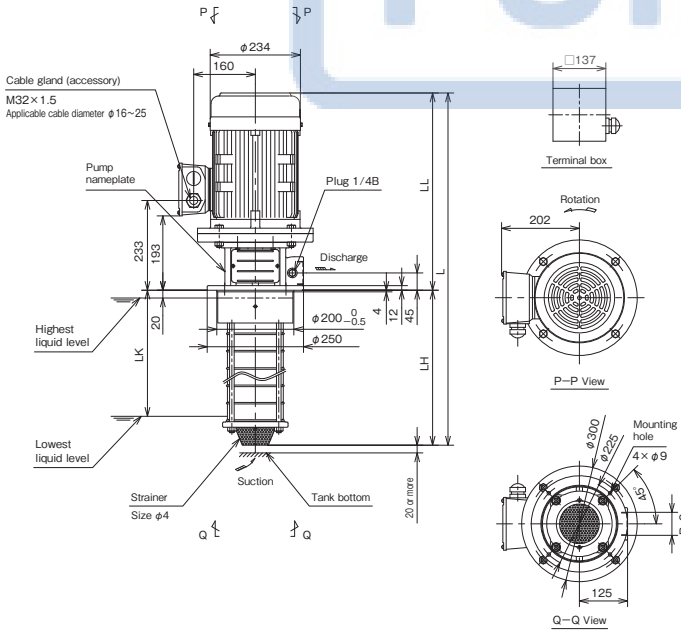

(Unit : mm)

Output kW	LL
5.5	512
7.5	547

Fig.4

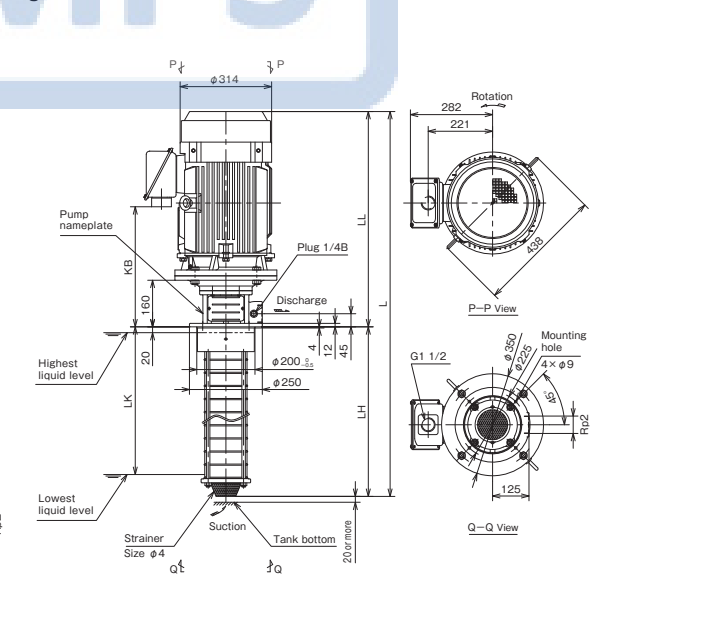

(Unit : mm)

Output kW	KB	LL
11/15	382	709
18.5	412	739

## Dimensions

● Discharge diameter : 50mm, Nominal flow rate : 10m<sup>3</sup>/h

50Hz

(Unit : mm)

(Unit : mm)

Type	Fig.	L	LH	LK	Approx. mass(kg)	
50LVS10-5/2-5.75-e	1	631	282	207	28	
50LVS10-6/2-5.75-e		661	312	237	28	
50LVS10-8/2-5.75-e		721	372	297	30	
50LVS10-10/2-5.75-e		781	432	357	31	
50LVS10-12/2-5.75-e		841	492	417	32	
50LVS10-14/2-5.75-e		901	552	477	34	
50LVS10-16/2-5.75-e		961	612	537	35	
50LVS10-18/2-5.75-e		1021	672	597	36	
50LVS10-20/2-5.75-e		1081	732	657	38	
50LVS10-22/2-5.75-e		1141	792	717	39	
50LVS10-5/3-51.1-e		2	691	282	207	32
50LVS10-6/3-51.1-e			721	312	237	33
50LVS10-8/3-51.1-e			781	372	297	34
50LVS10-10/3-51.1-e	841		432	357	35	
50LVS10-12/3-51.1-e	901		492	417	37	
50LVS10-14/3-51.1-e	961		552	477	38	
50LVS10-16/3-51.1-e	1021		612	537	39	
50LVS10-18/3-51.1-e	1081		672	597	40	
50LVS10-20/3-51.1-e	1141		732	657	42	
50LVS10-22/3-51.1-e	1201		792	717	43	
50LVS10-5/4-51.5-e	691		282	207	36	
50LVS10-6/4-51.5-e	721		312	237	36	
50LVS10-8/4-51.5-e	781		372	297	38	
50LVS10-10/4-51.5-e	841		432	357	39	
50LVS10-12/4-51.5-e	901		492	417	40	
50LVS10-14/4-51.5-e	961		552	477	42	
50LVS10-16/4-51.5-e	1021		612	537	43	
50LVS10-18/4-51.5-e	1081		672	597	44	
50LVS10-20/4-51.5-e	1141		732	657	46	
50LVS10-22/4-51.5-e	1201		792	717	47	
50LVS10-5/5-52.2-e	691		282	207	39	
50LVS10-6/5-52.2-e	721		312	237	40	
50LVS10-8/5-52.2-e	781		372	297	41	
50LVS10-10/5-52.2-e	841		432	357	43	
50LVS10-12/5-52.2-e	901		492	417	44	
50LVS10-14/5-52.2-e	961		552	477	45	
50LVS10-16/5-52.2-e	1021		612	537	47	
50LVS10-18/5-52.2-e	1081		672	597	48	
50LVS10-20/5-52.2-e	1141		732	657	49	
50LVS10-22/5-52.2-e	1201		792	717	51	
50LVS10-6/6-52.2-e	721		312	237	40	
50LVS10-8/6-52.2-e	781		372	297	41	
50LVS10-10/6-52.2-e	841		432	357	43	
50LVS10-12/6-52.2-e	901	492	417	44		
50LVS10-14/6-52.2-e	961	552	477	45		
50LVS10-16/6-52.2-e	1021	612	537	47		
50LVS10-18/6-52.2-e	1081	672	597	48		
50LVS10-20/6-52.2-e	1141	732	657	49		
50LVS10-22/6-52.2-e	1201	792	717	51		

Type	Fig.	L	LH	LK	Approx. mass(kg)
50LVS10-8/8-53.0-e	2	816	372	297	51
50LVS10-10/8-53.0-e		876	432	357	52
50LVS10-12/8-53.0-e		936	492	417	53
50LVS10-14/8-53.0-e		996	552	477	55
50LVS10-16/8-53.0-e		1056	612	537	56
50LVS10-18/8-53.0-e		1116	672	597	57
50LVS10-20/8-53.0-e		1176	732	657	59
50LVS10-22/8-53.0-e		1236	792	717	60
50LVS10-10/10-54.0-e		881	432	357	58
50LVS10-12/10-54.0-e		941	492	417	59
50LVS10-14/10-54.0-e		1001	552	477	60
50LVS10-16/10-54.0-e		1061	612	537	62
50LVS10-18/10-54.0-e		1121	672	597	63
50LVS10-20/10-54.0-e		1181	732	657	64
50LVS10-22/10-54.0-e		1241	792	717	66
50LVS10-12/12-54.0-e		941	492	417	59
50LVS10-14/12-54.0-e		1001	552	477	60
50LVS10-16/12-54.0-e		1061	612	537	62
50LVS10-18/12-54.0-e		1121	672	597	63
50LVS10-20/12-54.0-e	1181	732	657	64	
50LVS10-22/12-54.0-e	1241	792	717	66	
50LVS10-14/14-55.5-e	3	1064	552	477	88
50LVS10-16/14-55.5-e		1124	612	537	89
50LVS10-18/14-55.5-e		1184	672	597	91
50LVS10-20/14-55.5-e		1244	732	657	92
50LVS10-22/14-55.5-e		1304	792	717	93
50LVS10-16/16-55.5-e		1124	612	537	90
50LVS10-18/16-55.5-e		1184	672	597	91
50LVS10-20/16-55.5-e		1244	732	657	92
50LVS10-22/16-55.5-e		1304	792	717	93
50LVS10-18/18-57.5-e		1219	672	597	98
50LVS10-20/18-57.5-e		1279	732	657	99
50LVS10-22/18-57.5-e		1339	792	717	100
50LVS10-20/20-57.5-e		1279	732	657	99
50LVS10-22/20-57.5-e	1339	792	717	100	
50LVS10-22/22-57.5-e	1339	792	717	101	

●Discharge diameter:50mm, Nominal flow rate: 10m<sup>3</sup>/h

60Hz

(Unit : mm)

(Unit : mm)

Type	Fig.	L	LH	LK	Approx. mass(kg)
50LVS10-5/1-6.75-e	1	631	282	207	28
50LVS10-6/1-6.75-e		661	312	237	28
50LVS10-8/1-6.75-e		721	372	297	30
50LVS10-10/1-6.75-e		781	432	357	31
50LVS10-12/1-6.75-e		841	492	417	32
50LVS10-5/2-61.5-e	2	691	282	207	36
50LVS10-6/2-61.5-e		721	312	237	36
50LVS10-8/2-61.5-e		781	372	297	38
50LVS10-10/2-61.5-e		841	432	357	39
50LVS10-12/2-61.5-e		901	492	417	40
50LVS10-14/2-61.5-e		961	552	477	42
50LVS10-16/2-61.5-e		1021	612	537	43
50LVS10-18/2-61.5-e		1081	672	597	44
50LVS10-20/2-61.5-e		1141	732	657	46
50LVS10-22/2-61.5-e		1201	792	717	47
50LVS10-5/3-62.2-e		691	282	207	39
50LVS10-6/3-62.2-e		721	312	237	40
50LVS10-8/3-62.2-e		781	372	297	41
50LVS10-10/3-62.2-e		841	432	357	42
50LVS10-12/3-62.2-e		901	492	417	44
50LVS10-14/3-62.2-e		961	552	477	45
50LVS10-16/3-62.2-e		1021	612	537	46
50LVS10-18/3-62.2-e		1081	672	597	48
50LVS10-20/3-62.2-e		1141	732	657	49
50LVS10-22/3-62.2-e		1201	792	717	50
50LVS10-5/4-63.0-e		726	282	207	48
50LVS10-6/4-63.0-e		756	312	237	49
50LVS10-8/4-63.0-e		816	372	297	50
50LVS10-10/4-63.0-e		876	432	357	52
50LVS10-12/4-63.0-e		936	492	417	53
50LVS10-14/4-63.0-e		996	552	477	54
50LVS10-16/4-63.0-e		1056	612	537	56
50LVS10-18/4-63.0-e		1116	672	597	57
50LVS10-20/4-63.0-e		1176	732	657	58
50LVS10-22/4-63.0-e	1236	792	717	60	
50LVS10-5/5-63.0-e	726	282	207	48	
50LVS10-6/5-63.0-e	756	312	237	49	
50LVS10-8/5-63.0-e	816	372	297	50	
50LVS10-10/5-63.0-e	876	432	357	52	
50LVS10-12/5-63.0-e	936	492	417	53	
50LVS10-14/5-63.0-e	996	552	477	54	
50LVS10-16/5-63.0-e	1056	612	537	56	
50LVS10-18/5-63.0-e	1116	672	597	57	
50LVS10-20/5-63.0-e	1176	732	657	58	
50LVS10-22/5-63.0-e	1236	792	717	60	
50LVS10-6/6-64.0-e	761	312	237	55	
50LVS10-8/6-64.0-e	821	372	297	56	
50LVS10-10/6-64.0-e	881	432	357	57	
50LVS10-12/6-64.0-e	941	492	417	59	
50LVS10-14/6-64.0-e	1001	552	477	60	
50LVS10-16/6-64.0-e	1061	612	537	61	
50LVS10-18/6-64.0-e	1121	672	597	63	
50LVS10-20/6-64.0-e	1181	732	657	64	
50LVS10-22/6-64.0-e	1241	792	717	65	

Type	Fig.	L	LH	LK	Approx. mass(kg)
50LVS10-8/8-65.5-e	3	884	372	297	83
50LVS10-10/8-65.5-e		944	432	357	85
50LVS10-12/8-65.5-e		1004	492	417	86
50LVS10-14/8-65.5-e		1064	552	477	87
50LVS10-16/8-65.5-e		1124	612	537	89
50LVS10-18/8-65.5-e		1184	672	597	90
50LVS10-20/8-65.5-e		1244	732	657	91
50LVS10-22/8-65.5-e		1304	792	717	93
50LVS10-9/9-65.5-e		914	402	327	84
50LVS10-12/9-65.5-e		1004	492	417	86
50LVS10-14/9-65.5-e		1064	552	477	88
50LVS10-16/9-65.5-e		1124	612	537	89
50LVS10-18/9-65.5-e		1184	672	597	90
50LVS10-20/9-65.5-e		1244	732	657	91
50LVS10-22/9-65.5-e		1304	792	717	93
50LVS10-10/10-67.5-e		979	432	357	92
50LVS10-12/10-67.5-e		1039	492	417	93
50LVS10-14/10-67.5-e		1099	552	477	94
50LVS10-16/10-67.5-e		1159	612	537	96
50LVS10-18/10-67.5-e		1219	672	597	97
50LVS10-20/10-67.5-e		1279	732	657	98
50LVS10-22/10-67.5-e		1339	792	717	100
50LVS10-12/12-67.5-e		1039	492	417	93
50LVS10-14/12-67.5-e		1099	552	477	94
50LVS10-16/12-67.5-e		1159	612	537	96
50LVS10-18/12-67.5-e		1219	672	597	97
50LVS10-20/12-67.5-e		1279	732	657	98
50LVS10-22/12-67.5-e		1339	792	717	100
50LVS10-14/14-611-e	4	1261	552	477	169
50LVS10-16/14-611-e		1321	612	537	170
50LVS10-18/14-611-e		1381	672	597	172
50LVS10-20/14-611-e		1441	732	657	173
50LVS10-22/14-611-e		1501	792	717	174
50LVS10-16/16-611-e		1321	612	537	170
50LVS10-18/16-611-e		1381	672	597	172
50LVS10-20/16-611-e		1441	732	657	173
50LVS10-22/16-611-e		1501	792	717	174
50LVS10-18/18-611-e		1381	672	597	172
50LVS10-20/18-611-e		1441	732	657	173
50LVS10-22/18-611-e		1501	792	717	175

●Discharge diameter: 50mm, Nominal flow rate: 15m<sup>3</sup>/h

50Hz

(Unit : mm)

Type	Fig.	L	LH	LK	Approx. mass(kg)
50LVS15-3/1-51.1-e	2	676	267	192	31
50LVS15-4/1-51.1-e		721	312	237	32
50LVS15-5/1-51.1-e		766	357	282	33
50LVS15-6/1-51.1-e		811	402	327	34
50LVS15-7/1-51.1-e		856	447	372	35
50LVS15-8/1-51.1-e		901	492	417	36
50LVS15-3/2-52.2-e		676	267	192	39
50LVS15-4/2-52.2-e		721	312	237	39
50LVS15-5/2-52.2-e		766	357	282	40
50LVS15-6/2-52.2-e		811	402	327	41
50LVS15-7/2-52.2-e		856	447	372	42
50LVS15-8/2-52.2-e		901	492	417	43
50LVS15-10/2-52.2-e		991	582	507	44
50LVS15-12/2-52.2-e		1081	672	597	46
50LVS15-14/2-52.2-e		1171	762	687	48
50LVS15-3/3-53.0-e		711	267	192	48
50LVS15-4/3-53.0-e		756	312	237	48
50LVS15-5/3-53.0-e		801	357	282	49
50LVS15-6/3-53.0-e		846	402	327	50
50LVS15-7/3-53.0-e		891	447	372	51
50LVS15-8/3-53.0-e		936	492	417	52
50LVS15-10/3-53.0-e		1026	582	507	54
50LVS15-12/3-53.0-e		1116	672	597	55
50LVS15-14/3-53.0-e		1206	762	687	57
50LVS15-17/3-53.0-e		1341	897	822	59
50LVS15-4/4-54.0-e		761	312	237	54
50LVS15-5/4-54.0-e		806	357	282	55
50LVS15-6/4-54.0-e		851	402	327	56
50LVS15-7/4-54.0-e		896	447	372	57
50LVS15-8/4-54.0-e		941	492	417	58
50LVS15-10/4-54.0-e		1031	582	507	59
50LVS15-12/4-54.0-e		1121	672	597	61
50LVS15-14/4-54.0-e		1211	762	687	63
50LVS15-17/4-54.0-e		1346	897	822	65
50LVS15-5/5-54.0-e		806	357	282	55
50LVS15-6/5-54.0-e		851	402	327	56
50LVS15-7/5-54.0-e		896	447	372	57
50LVS15-8/5-54.0-e		941	492	417	58
50LVS15-10/5-54.0-e		1031	582	507	59
50LVS15-12/5-54.0-e		1121	672	597	61
50LVS15-14/5-54.0-e	1211	762	687	63	
50LVS15-17/5-54.0-e	1346	897	822	65	
50LVS15-6/6-55.5-e	914	402	327	84	
50LVS15-7/6-55.5-e	959	447	372	84	
50LVS15-8/6-55.5-e	1004	492	417	85	
50LVS15-10/6-55.5-e	1094	582	507	87	
50LVS15-12/6-55.5-e	1184	672	597	89	
50LVS15-14/6-55.5-e	1274	762	687	90	
50LVS15-17/6-55.5-e	1409	897	822	93	
50LVS15-7/7-55.5-e	959	447	372	85	
50LVS15-8/7-55.5-e	1004	492	417	85	
50LVS15-10/7-55.5-e	1094	582	507	87	
50LVS15-12/7-55.5-e	1184	672	597	89	
50LVS15-14/7-55.5-e	1274	762	687	90	
50LVS15-17/7-55.5-e	1409	897	822	93	
50LVS15-8/8-57.5-e	1039	492	417	92	
50LVS15-10/8-57.5-e	1129	582	507	94	
50LVS15-12/8-57.5-e	1219	672	597	96	
50LVS15-14/8-57.5-e	1309	762	687	97	
50LVS15-17/8-57.5-e	1444	897	822	100	
50LVS15-9/9-57.5-e	1084	537	462	93	
50LVS15-12/9-57.5-e	1219	672	597	96	
50LVS15-14/9-57.5-e	1309	762	687	97	
50LVS15-17/9-57.5-e	1444	897	822	100	
50LVS15-10/10-511-e	1291	582	507	169	
50LVS15-12/10-511-e	1381	672	597	170	
50LVS15-14/10-511-e	1471	762	687	172	
50LVS15-17/10-511-e	1606	897	822	174	
50LVS15-12/12-511-e	1381	672	597	171	
50LVS15-14/12-511-e	1471	762	687	172	
50LVS15-17/12-511-e	1606	897	822	175	
50LVS15-14/14-511-e	1471	762	687	173	
50LVS15-17/14-511-e	1606	897	822	175	
50LVS15-17/17-515-e	1606	897	822	187	

60Hz

(Unit : mm)

Type	Fig.	L	LH	LK	Approx. mass(kg)
50LVS15-3/1-61.5-e	2	676	267	192	35
50LVS15-4/1-61.5-e		721	312	237	36
50LVS15-5/1-61.5-e		766	357	282	37
50LVS15-6/1-61.5-e		811	402	327	38
50LVS15-7/1-61.5-e		856	447	372	38
50LVS15-8/1-61.5-e		901	492	417	39
50LVS15-10/1-61.5-e		991	582	507	41
50LVS15-3/2-63.0-e		711	267	192	48
50LVS15-4/2-63.0-e		756	312	237	48
50LVS15-5/2-63.0-e		801	357	282	49
50LVS15-6/2-63.0-e		846	402	327	50
50LVS15-7/2-63.0-e		891	447	372	51
50LVS15-8/2-63.0-e		936	492	417	52
50LVS15-10/2-63.0-e		1026	582	507	54
50LVS15-12/2-63.0-e		1116	672	597	55
50LVS15-14/2-63.0-e		1206	762	687	57
50LVS15-17/2-63.0-e		1341	897	822	59
50LVS15-3/3-64.0-e		716	267	192	53
50LVS15-4/3-64.0-e		761	312	237	54
50LVS15-5/3-64.0-e		806	357	282	55
50LVS15-6/3-64.0-e		851	402	327	56
50LVS15-7/3-64.0-e		896	447	372	56
50LVS15-8/3-64.0-e		941	492	417	57
50LVS15-10/3-64.0-e		1031	582	507	59
50LVS15-12/3-64.0-e		1121	672	597	61
50LVS15-14/3-64.0-e		1211	762	687	62
50LVS15-17/3-64.0-e		1346	897	822	65
50LVS15-4/4-65.5-e		824	312	237	81
50LVS15-5/4-65.5-e		869	357	282	82
50LVS15-6/4-65.5-e		914	402	327	83
50LVS15-7/4-65.5-e		959	447	372	84
50LVS15-8/4-65.5-e		1004	492	417	85
50LVS15-10/4-65.5-e		1094	582	507	87
50LVS15-12/4-65.5-e		1184	672	597	88
50LVS15-14/4-65.5-e		1274	762	687	90
50LVS15-17/4-65.5-e		1409	897	822	92
50LVS15-5/5-67.5-e		904	357	282	89
50LVS15-6/5-67.5-e		949	402	327	90
50LVS15-7/5-67.5-e		994	447	372	91
50LVS15-8/5-67.5-e		1039	492	417	92
50LVS15-10/5-67.5-e	1129	582	507	93	
50LVS15-12/5-67.5-e	1219	672	597	95	
50LVS15-14/5-67.5-e	1309	762	687	97	
50LVS15-17/5-67.5-e	1444	897	822	99	
50LVS15-6/6-611-e	1111	402	327	164	
50LVS15-7/6-611-e	1156	447	372	165	
50LVS15-8/6-611-e	1201	492	417	166	
50LVS15-10/6-611-e	1291	582	507	168	
50LVS15-12/6-611-e	1381	672	597	169	
50LVS15-14/6-611-e	1471	762	687	171	
50LVS15-17/6-611-e	1606	897	822	174	
50LVS15-7/7-611-e	1156	447	372	165	
50LVS15-8/7-611-e	1201	492	417	166	
50LVS15-10/7-611-e	1291	582	507	168	
50LVS15-12/7-611-e	1381	672	597	170	
50LVS15-14/7-611-e	1471	762	687	171	
50LVS15-17/7-611-e	1606	897	822	174	
50LVS15-8/8-611-e	1201	492	417	167	
50LVS15-10/8-611-e	1291	582	507	168	
50LVS15-12/8-611-e	1381	672	597	170	
50LVS15-14/8-611-e	1471	762	687	172	
50LVS15-17/8-611-e	1606	897	822	174	
50LVS15-10/10-615-e	1291	582	507	180	
50LVS15-12/10-615-e	1381	672	597	181	
50LVS15-14/10-615-e	1471	762	687	183	
50LVS15-17/10-615-e	1606	897	822	185	
50LVS15-12/12-618-e	1411	672	597	198	
50LVS15-14/12-618-e	1501	762	687	199	
50LVS15-17/12-618-e	1636	897	822	202	



●Discharge diameter: 50mm, Nominal flow rate: 20m<sup>3</sup>/h

50Hz

(Unit : mm)

Type	Fig.	L	LH	LK	Approx. mass(kg)
50LVS20-3/1-51.1-e	2	676	267	192	31
50LVS20-4/1-51.1-e		721	312	237	32
50LVS20-5/1-51.1-e		766	357	282	33
50LVS20-6/1-51.1-e		811	402	327	34
50LVS20-3/2-52.2-e		676	267	192	39
50LVS20-4/2-52.2-e		721	312	237	39
50LVS20-5/2-52.2-e		766	357	282	40
50LVS20-6/2-52.2-e		811	402	327	41
50LVS20-7/2-52.2-e		856	447	372	42
50LVS20-8/2-52.2-e		901	492	417	43
50LVS20-10/2-52.2-e		991	582	507	44
50LVS20-12/2-52.2-e		1081	672	597	46
50LVS20-3/3-54.0-e		716	267	192	53
50LVS20-4/3-54.0-e		761	312	237	54
50LVS20-5/3-54.0-e		806	357	282	55
50LVS20-6/3-54.0-e		851	402	327	56
50LVS20-7/3-54.0-e		896	447	372	56
50LVS20-8/3-54.0-e		941	492	417	57
50LVS20-10/3-54.0-e	1031	582	507	59	
50LVS20-12/3-54.0-e	1121	672	597	61	
50LVS20-14/3-54.0-e	1211	762	687	62	
50LVS20-17/3-54.0-e	1346	897	822	65	
50LVS20-4/4-55.5-e	3	824	312	237	81
50LVS20-5/4-55.5-e		869	357	282	82
50LVS20-6/4-55.5-e		914	402	327	83
50LVS20-7/4-55.5-e		959	447	372	84
50LVS20-8/4-55.5-e		1004	492	417	85
50LVS20-10/4-55.5-e		1094	582	507	87
50LVS20-12/4-55.5-e		1184	672	597	88
50LVS20-14/4-55.5-e		1274	762	687	90
50LVS20-17/4-55.5-e		1409	897	822	92
50LVS20-5/5-55.5-e		869	357	282	83
50LVS20-6/5-55.5-e		914	402	327	83
50LVS20-7/5-55.5-e		959	447	372	84
50LVS20-8/5-55.5-e		1004	492	417	85
50LVS20-10/5-55.5-e		1094	582	507	87
50LVS20-12/5-55.5-e		1184	672	597	88
50LVS20-14/5-55.5-e		1274	762	687	90
50LVS20-17/5-55.5-e		1409	897	822	93
50LVS20-6/6-57.5-e		949	402	327	90
50LVS20-7/6-57.5-e		994	447	372	91
50LVS20-8/6-57.5-e		1039	492	417	92
50LVS20-10/6-57.5-e		1129	582	507	94
50LVS20-12/6-57.5-e		1219	672	597	95
50LVS20-14/6-57.5-e		1309	762	687	97
50LVS20-17/6-57.5-e		1444	897	822	99
50LVS20-7/7-57.5-e		994	447	372	91
50LVS20-8/7-57.5-e		1039	492	417	92
50LVS20-10/7-57.5-e		1129	582	507	94
50LVS20-12/7-57.5-e		1219	672	597	95
50LVS20-14/7-57.5-e	1309	762	687	97	
50LVS20-17/7-57.5-e	1444	897	822	100	
50LVS20-8/8-511-e	4	1201	492	417	167
50LVS20-10/8-511-e		1291	582	507	168
50LVS20-12/8-511-e		1381	672	597	170
50LVS20-14/8-511-e		1471	762	687	172
50LVS20-17/8-511-e		1606	897	822	174
50LVS20-10/10-511-e		1291	582	507	168
50LVS20-12/10-511-e		1381	672	597	170
50LVS20-14/10-511-e		1471	762	687	172
50LVS20-17/10-511-e		1606	897	822	174
50LVS20-12/12-515-e		1381	672	597	182
50LVS20-14/12-515-e		1471	762	687	183
50LVS20-17/12-515-e		1606	897	822	186
50LVS20-14/14-515-e		1471	762	687	183
50LVS20-17/14-515-e		1606	897	822	186
50LVS20-17/17-518-e		1636	897	822	203

60Hz

(Unit : mm)

Type	Fig.	L	LH	LK	Approx. mass(kg)	
50LVS20-3/1-62.2-e	2	676	267	192	39	
50LVS20-4/1-62.2-e		721	312	237	39	
50LVS20-5/1-62.2-e		766	357	282	40	
50LVS20-6/1-62.2-e		811	402	327	41	
50LVS20-7/1-62.2-e		856	447	372	42	
50LVS20-3/2-64.0-e		716	267	192	53	
50LVS20-4/2-64.0-e		761	312	237	54	
50LVS20-5/2-64.0-e		806	357	282	55	
50LVS20-6/2-64.0-e		851	402	327	56	
50LVS20-7/2-64.0-e		896	447	372	56	
50LVS20-8/2-64.0-e		941	492	417	57	
50LVS20-10/2-64.0-e		1031	582	507	59	
50LVS20-12/2-64.0-e		1121	672	597	61	
50LVS20-3/3-65.5-e		3	779	267	192	80
50LVS20-4/3-65.5-e			824	312	237	81
50LVS20-5/3-65.5-e			869	357	282	82
50LVS20-6/3-65.5-e			914	402	327	83
50LVS20-7/3-65.5-e			959	447	372	84
50LVS20-8/3-65.5-e	1004		492	417	85	
50LVS20-10/3-65.5-e	1094		582	507	86	
50LVS20-12/3-65.5-e	1184		672	597	88	
50LVS20-14/3-65.5-e	1274		762	687	90	
50LVS20-17/3-65.5-e	1409		897	822	92	
50LVS20-4/4-67.5-e	859		312	237	88	
50LVS20-5/4-67.5-e	904		357	282	89	
50LVS20-6/4-67.5-e	949		402	327	90	
50LVS20-7/4-67.5-e	994		447	372	91	
50LVS20-8/4-67.5-e	1039		492	417	91	
50LVS20-10/4-67.5-e	1129		582	507	93	
50LVS20-12/4-67.5-e	1219		672	597	95	
50LVS20-14/4-67.5-e	1309		762	687	96	
50LVS20-17/4-67.5-e	1444		897	822	99	
50LVS20-5/5-611-e	1066		357	282	163	
50LVS20-6/5-611-e	1111		402	327	164	
50LVS20-7/5-611-e	1156		447	372	165	
50LVS20-8/5-611-e	1201		492	417	166	
50LVS20-10/5-611-e	1291		582	507	168	
50LVS20-12/5-611-e	1381		672	597	169	
50LVS20-14/5-611-e	1471		762	687	171	
50LVS20-17/5-611-e	1606		897	822	173	
50LVS20-6/6-611-e	4		1111	402	327	164
50LVS20-7/6-611-e		1156	447	372	165	
50LVS20-8/6-611-e		1201	492	417	166	
50LVS20-10/6-611-e		1291	582	507	168	
50LVS20-12/6-611-e		1381	672	597	169	
50LVS20-14/6-611-e		1471	762	687	171	
50LVS20-17/6-611-e		1606	897	822	174	
50LVS20-7/7-615-e		1156	447	372	176	
50LVS20-8/7-615-e		1201	492	417	177	
50LVS20-10/7-615-e		1291	582	507	179	
50LVS20-12/7-615-e		1381	672	597	181	
50LVS20-14/7-615-e		1471	762	687	182	
50LVS20-17/7-615-e		1606	897	822	185	
50LVS20-8/8-615-e		1201	492	417	177	
50LVS20-10/8-615-e		1291	582	507	179	
50LVS20-12/8-615-e		1381	672	597	181	
50LVS20-14/8-615-e		1471	762	687	182	
50LVS20-17/8-615-e		1606	897	822	185	
50LVS20-10/10-618-e	1321	582	507	196		
50LVS20-12/10-618-e	1411	672	597	197		
50LVS20-14/10-618-e	1501	762	687	199		
50LVS20-17/10-618-e	1636	897	822	201		

Detailed drawing of the terminal box

● Output 0.75 kW

■ Assembly drawing

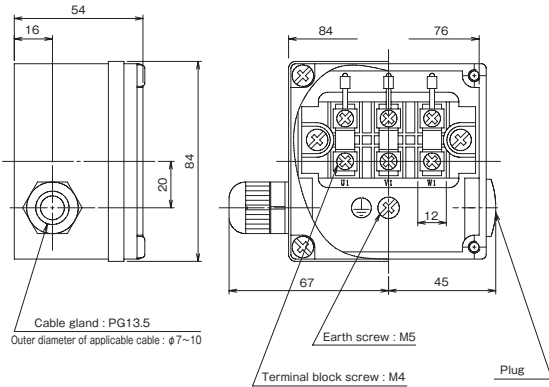

■ Connection diagram

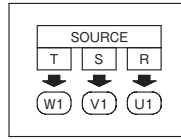

● Output 1.1 ~ 4.0 kW

■ Assembly drawing

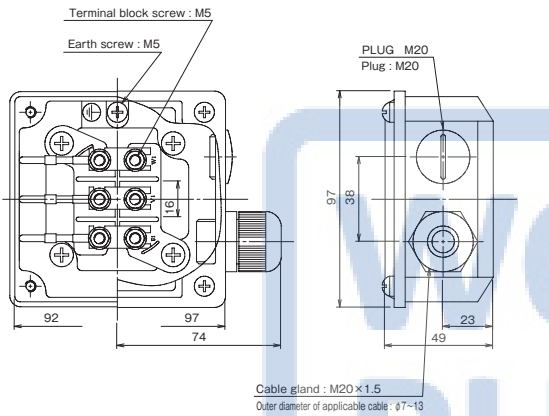

■ Connection diagram

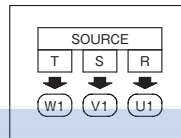

● Output 5.5, 7.5 kW

■ Assembly drawing

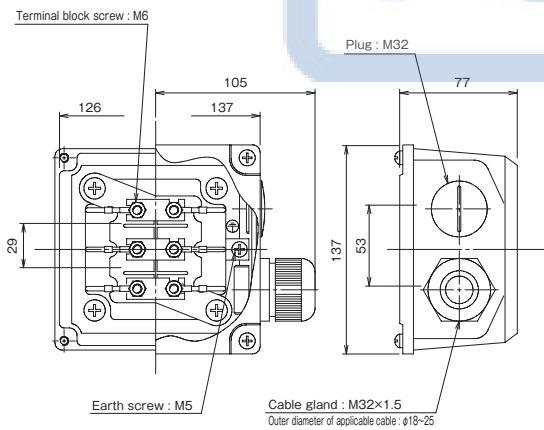

■ Connection diagram

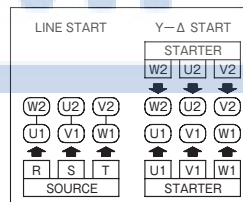

● Output 11 ~ 18.5 kW

■ Assembly drawing

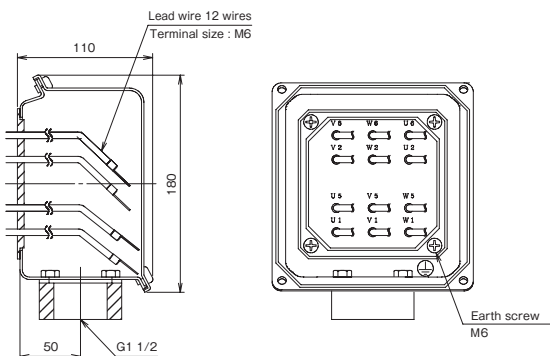

■ Connection diagram

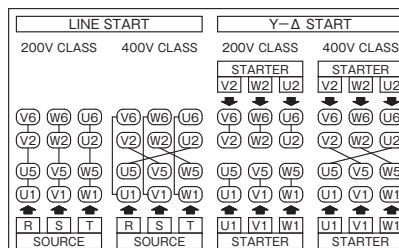

Sectional drawing

●32LVS-e

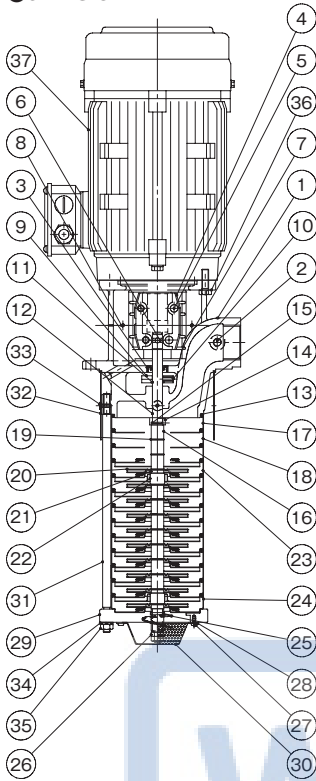

No.	Part name	Material
1	Discharge casing	FC200
2	Air vent valve	BRASS
3	Oil seal	NBR
4	Coupling	FC0205
5	Hexagon socket head bolt	SCM435
6	Shaft pin	SUS316
7	Coupling cover	SUS304
8	Cross-recessed pan head screw	SUS304
9	Oil thrower	SUS304
10	Set screw	SCM435
11	O-ring	FKM
12	Main shaft	SUS420J2
13	Gasket	—
14	Shaft bushing	SUS304
15	Shaft ring	SUS316
16	Sleeve	SUS304
17	Intermediate casing (Final stage)	SUS304
18	Intermediate casing	SUS304
19	Shim	SUS304
20	Impeller	SUS304
21	Baffle	SUS304
22	Bearings	SiC
23	Bearing casing	SUS304+SiC
24	Intermediate casing (First stage)	SUS304
25	Screw	SUS304
26	Hardlock nut	SUS304
27	Cross-recessed pan head screw	SUS304
28	Protection plate	SUS304
29	Suction casing	FC200
30	Strainer	SUS304
31	Through bolt	SUS304
32	Outer sleeve	SUS304
33	Cross-recessed flat head screw	SUS304
34	Spring washer	SUS304
35	Hexagon nut	SUS304
36	Hexagon bolt	SUS304
37	Motor	—

Note 1) The materials in the table above are equivalents.  
Note 2) Structure and other details are subject to change without notice.

●50LVS-e

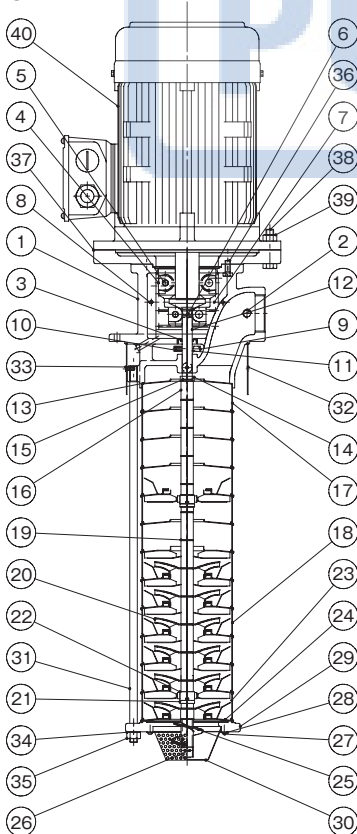

No.	Part name	Material
1	Discharge casing	FC200
2	Air vent valve	BRASS
3	Oil seal	NBR
4	Coupling	FC0205
5	Hexagon socket head bolt	SCM435
6	Shaft pin	SUS316
7	Coupling cover	SUS304
8	Cross-recessed pan head screw	SUS304
9	Oil thrower	SUS304
10	Set screw	SCM435
11	O-ring	FKM
12	Main shaft	SUS420J2
13	Gasket	—
14	Shaft bushing	SUS304
15	Shaft ring	SUS316
16	Sleeve	SUS304
17	Intermediate casing (Final stage)	SUS304
18	Intermediate casing	SUS304
19	Shim	SUS304
20	Impeller	SUS304
21	Baffle	SUS304
22	Bearings	SiC
23	Bearing casing	SUS304+SiC
24	Intermediate casing (First stage)	SUS304
25	Screw	SUS304
26	Hardlock nut	SUS304
27	Cross-recessed pan head screw	SUS304
28	Protection plate	SUS304
29	Suction casing	FCD450
30	Strainer	SUS304
31	Through bolt	SUS304
32	Outer sleeve	SUS304
33	Cross-recessed flat head screw	SUS304
34	Plain washer	SUS304
35	Hexagon nut	SUS304
36	Hexagon bolt	SUS304
37	Frame spacer	FCD450
38	Hexagon bolt	SUS304
39	Hexagon nut	SUS304
40	Motor	—

Note 1) The materials in the table above are equivalents.  
Note 2) Structure and other details are subject to change without notice.

**Features**

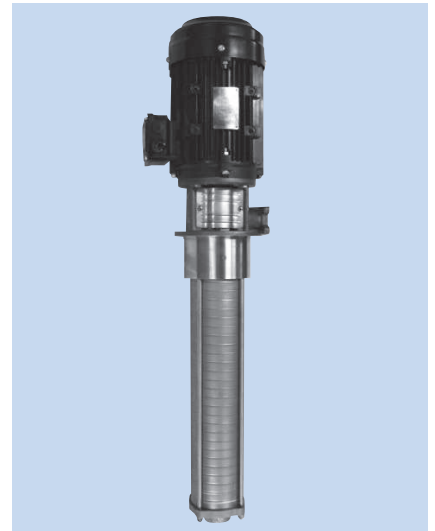

Please note that the paint color, etc. of the actual unit may partially differ from the photo.

- ① Energy-saving pump equipped with a Top Runner efficiency (equivalent to IE3) motor.
- ② Non-seal (mechanical seal-less) structure is adopted.
- ③ Stainless steel is used in the pump's main liquid contact part and SiC bearings with increased wear resistance are adopted.
- ④ Measures against air suction into the pump are taken when the fluid level lowers.
- ⑤ EU RoHS Directive (RoHS 6 restricted substances) compliant.  
Output range for standard specification: 0.75 to 7.5kW.
- ⑥ EU Directive for CE marking compliant.
- ⑦ Energy saving by high efficiency impeller!
- ⑧ Diverse lineup offers a wider choice according to your applications:  
Discharge rate 50Hz: 10 to 500L/min, 60Hz: 10 to 600L/min  
Total head 50Hz: Maximum 230m, 60Hz: Maximum 260m  
Output: 0.75 to 18.5kW  
(0.75 to 7.5kW is NEMA Premium motor)

**Non-seal structure**

TERAL's original "non-seal" structure allows coolant to flow from a narrow clearance without using a seal between the pump section and the motor section.

**The advantages of a non-seal pump**

- 1 No trouble such as coolant leaks.**  
Helps cut down on running costs.
- 2 Prevents air entrainment.**  
Reduces initial problems.
- 3 Not easily affected by a small quantity of liquid or shut-off operations.**  
Enables a flexible operation system.

**※What is non-seal structure?**

This structure inwardly releases coolant by depressurizing through a narrow clearance without the use of a mechanical seal.

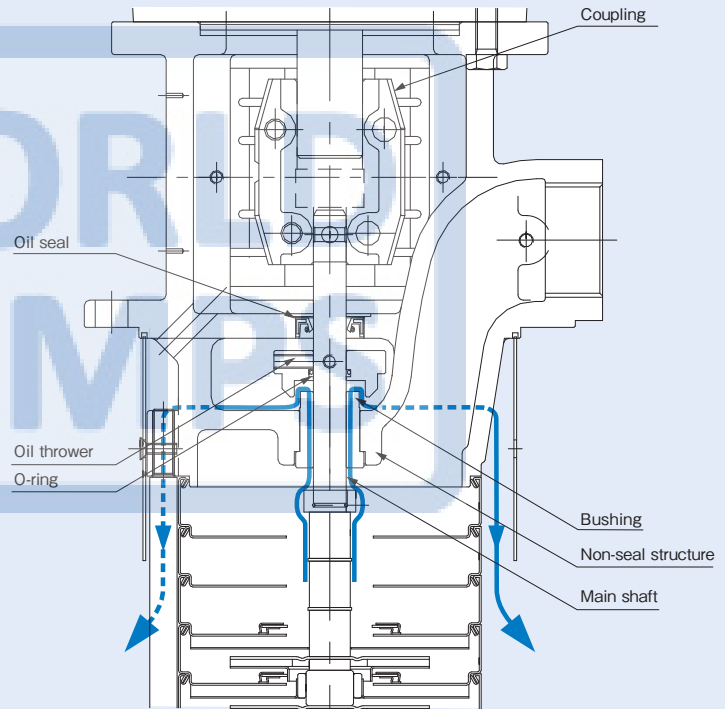

**Description of types**

**50 LVSS 10 - 20 / 12 - 6 7.5 -e**

①      ②      ③      ④      ⑤      ⑥      ⑦      ⑧

- ① Discharge diameter
- ② Model
- ③ Nominal flow rate (m<sup>3</sup>/h)
- ④ Number of casings
- ⑤ Number of impellers
- ⑥ Frequency 5:50Hz 6:60Hz
- ⑦ Output
- ⑧ Motor efficiency Top Runner efficiency (equivalent to IE3).

Standard Specification

Used liquid	Property of liquid	Fresh water, Cleaning liquid and Water soluble coolants (e.g. grinding liquid, cutting liquid after secondary treatment) *1
	Temperature	0 to 90°C (No frozen liquid)
	Allowable kinematic viscosity	1mm <sup>2</sup> /s
Installation location		Indoor Ambient temperature: 0 to 40°C, RH 85% or below (no condensation), Height above sea level : 1000m or less, Place not exposed to direct sunlight, Place in an area free of corrosive or explosive gas or vapor.
Material	Suction casing	Bore diameter 32: SCS14A, Bore diameter 50: SCS13
	Discharge casing	SCS13+SUS430
	Intermediate casing	SUS304
	Impeller	SUS304
	Main shaft	SUS420J2
Shaft seal structure		Non-seal (mechanical seal-less)
Motor	Type	Totally enclosed fan-cooled outdoor type *2
	Protection method	IP55
	Power source	3-phase 50/60/60Hz, 200/200/230V 0.75~7.5kW 3-phase 50/60/60Hz, 200/200/220V 11~18.5kW
	Thermal class	F
	Number of poles	2P
	Standard	IEC60034-1
Paint color	Pump	Munsell N1(Frame spacer for 5.5kW or more)
	Motor	Black

\*1 If the liquid contains hard sludge, such as abrasive powder, ground powder, or ground diamond grains, the service life might be shortened. Please set up a filter (magnet filter or paper filter, etc.).

\*2 The pump cannot be installed outside.

Special specification

Motor modifications	Voltage change *1, change of terminal box position *2, change of terminal box direction *3
---------------------	--

\*1 7.5kW or less (50Hz/380V,400V 60Hz/400V 460V)  
11kW or more(50Hz/380V,400V,415V,420V,440V 60Hz/400V,440V,460V 480V)

\*2 Change of terminal box position (every 90° when viewed from above)

\*3 Terminal box direction (every 90° when viewed from front), Applicable: 1.5 kW to 18.5 kW

Special accessory

Companion flange (discharge diameter 32 mm) *
---

\* The material is SCS13.

Table of Consumable Parts

Output (kW)	Bearing		Oil seal				O-ring (For oil thrower) Material: FKM	
	Load side	Unload side	Motor		Discharge casing		Bore diameter 32	Bore diameter 50
			Load side (Bearing side)	Unload side	Bore diameter 32	Bore diameter 50		
0.75	6204ZCC3	6201ZCC3	—	—	IS12257	SC16328	S12	S16
1.1		6304ZCC3	—	VC20407				
1.5	VC25407		VC25477					
2.2				6307ZCC3				
3.0	VC35527		VC30528					
4.0	6309ZCC3	6305ZCC3	VC45628	Please contact us				
5.5		6306ZCC3						
7.5								
11	7309B	6309ZCC3	Please contact us					
15								
18.5								

Selection chart

(Values at kinematic viscosity 1mm<sup>2</sup>/s, specific gravity 1)

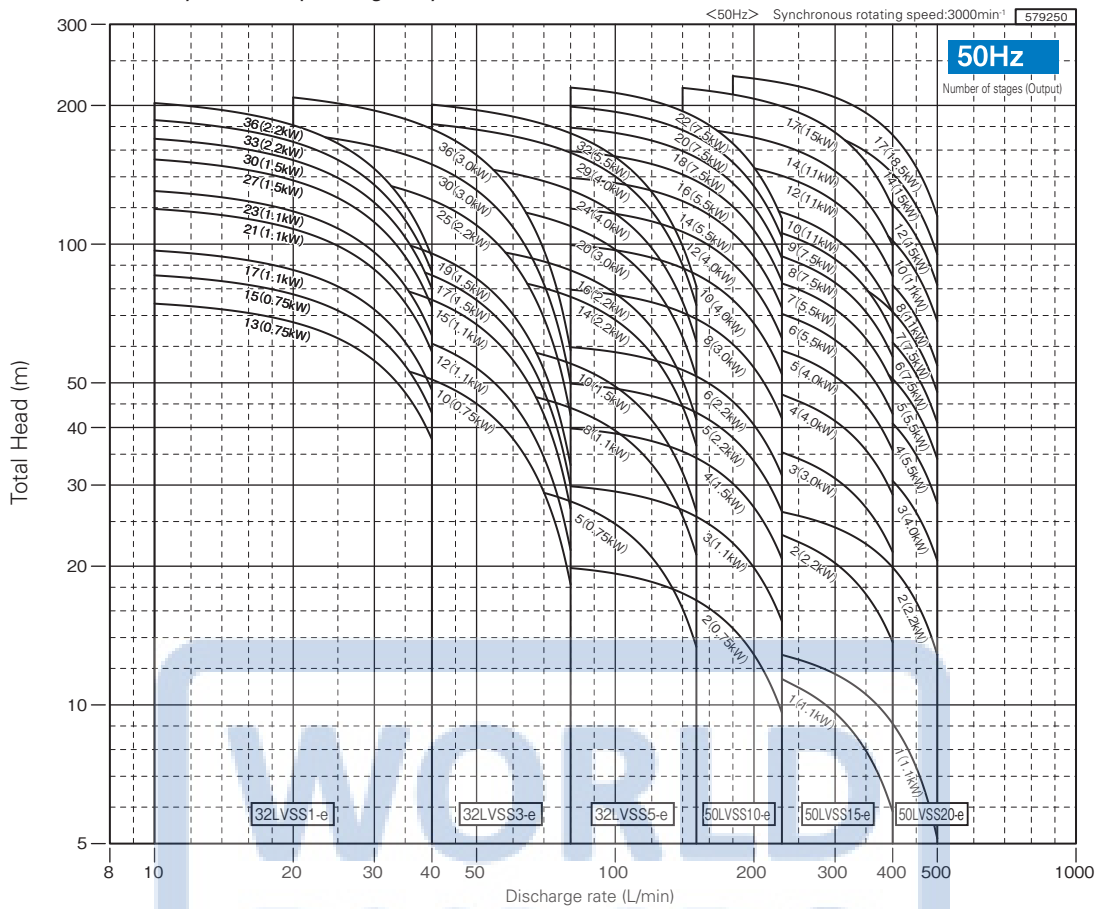

Note 1) The above selection chart reflects the full impeller condition of the units. The total head may be decreased depending on the flow rate if empty casings are involved because of pressure loss in the empty casings.

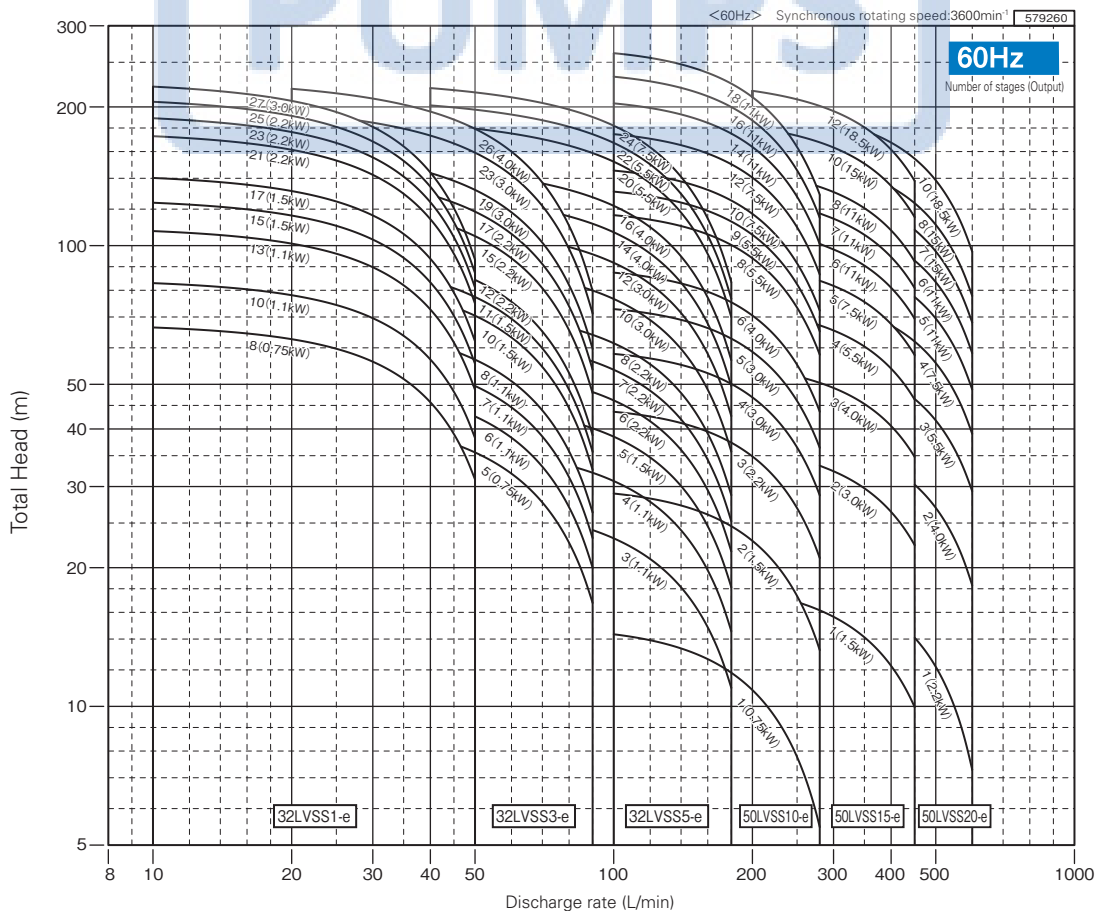

Note 1) The above selection chart reflects the full impeller condition of the units. The total head may be decreased depending on the flow rate if empty casings are involved because of pressure loss in the empty casings.

■ Pressure loss in the empty casings (50 Hz/60 Hz)

Pressure loss for 1 stage of empty casing is as follows:

LVSS1-e

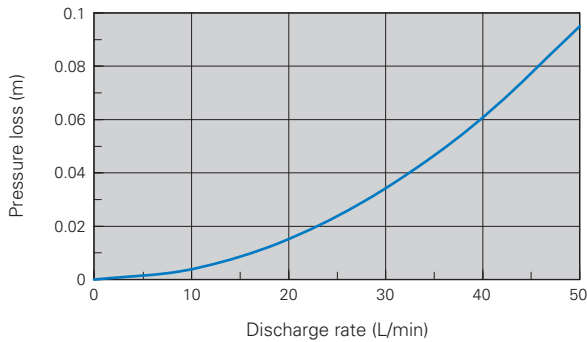

LVSS10-e

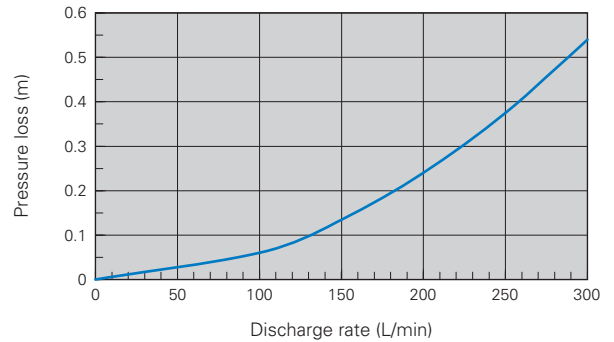

LVSS3-e

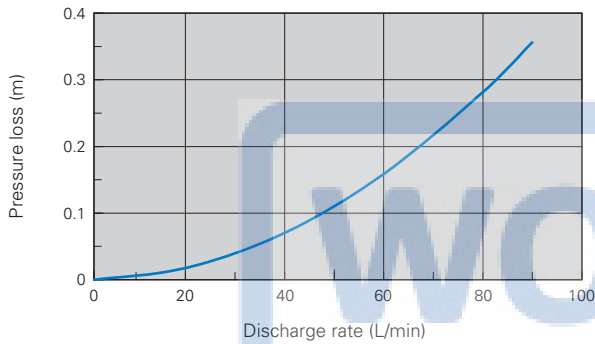

LVSS15-e

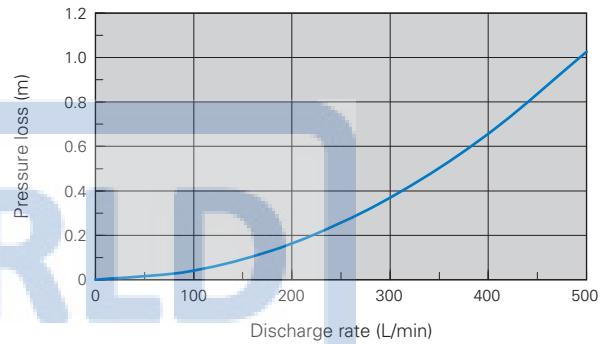

LVSS5-e

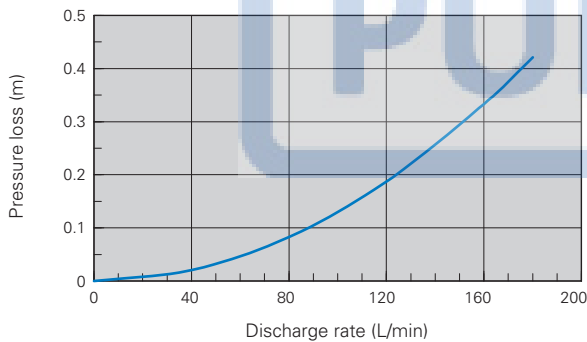

LVSS20-e

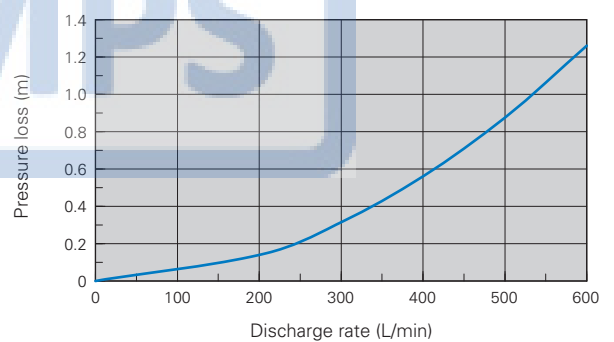

The selection chart is a performance chart of the full-impeller model (all casings are equipped with impeller). A pump with empty casings (without impeller) will have some influence on the total head of the pump depending on the flow rate due to its pressure loss. The pressure loss per 1 stage of empty casing of each model is as shown in the graph above. In the case of a pump with many stages of empty casings, the maximum flow rate may slightly decrease. For details, refer to the characteristic curve chart.

● Calculation example of total pump head in consideration of pressure loss of empty casing

- Pump type : 32LVSS5-20/5-5.75-e
- Specification flow rate: 100L/min
- Specification total head: 20m
- The number of stages: 20
- Number of impellers: 5

From the graph above, the pressure loss per 1 stage of empty casing is 0.13 m for a flow rate of 100L/min

The number of stages of the empty casing is 20 - 5 = 15 stages.

Total pressure loss = 0.13 × 15 ≒ 2.0m

From the selection chart, the total head is 25 m for a flow rate of 100L/min.

The pressure loss is subtracted from the total head.

Total head = 25 - 2.0 = 23.0m

Therefore, the total head of 32LVSS5-20/5-5.75-e is 23.0 m for a flow rate of 100 L/min.

## Specification table

50Hz

Bore diameter (mm)	Frequency (m³/h)	Type	Output (kW)	Rated voltage (V)	Rated current (A)	Starting current (A)	Discharge rate (L/min)	Total Head (m)				
32	1	32LVSS1-□/13-5.75-e	0.75	200	3.4	26	10~40	74.3 ~ 37.7				
		32LVSS1-□/15-5.75-e						85.6 ~ 43.0				
		32LVSS1-□/17-51.1-e	1.1		4.7	34		96.8 ~ 48.2				
		32LVSS1-□/21-51.1-e						119.3 ~ 58.4				
		32LVSS1-□/23-51.1-e						130.4 ~ 63.3				
		32LVSS1-□/27-51.5-e						152.7 ~ 73.0				
		32LVSS1-□/30-51.5-e	1.5		6.2	47		169.3 ~ 80.1				
		32LVSS1-□/33-52.2-e						185.9 ~ 87.0				
	32LVSS1-36/36-52.2-e	2.2	8.7		83	202.4 ~ 93.8						
	3	3	32LVSS3-□/10-5.75-e		0.75	3.4	26	20~80	58.7 ~ 18.2			
			32LVSS3-□/12-51.1-e		1.1	4.7	34		70.3 ~ 21.6			
			32LVSS3-□/15-51.1-e						87.7 ~ 26.6			
			32LVSS3-□/17-51.5-e		1.5	6.2	47		99.3 ~ 29.9			
			32LVSS3-□/19-51.5-e						110.9 ~ 33.1			
			32LVSS3-□/25-52.2-e		2.2	8.7	83		145.4 ~ 42.5			
			32LVSS3-□/30-53.0-e		3.0	12.2	129		174.0 ~ 50.0			
			32LVSS3-36/36-53.0-e						208.2 ~ 58.8			
			5		5	32LVSS5-□/5-5.75-e	0.75		3.4	26	40~150	31.6 ~ 13.3
						32LVSS5-□/8-51.1-e	1.1		4.7	34		50.6 ~ 21.1
						32LVSS5-□/10-51.5-e	1.5		6.2	47		63.2 ~ 26.3
						32LVSS5-□/14-52.2-e	2.2		8.7	83		88.3 ~ 36.5
	32LVSS5-□/16-52.2-e	100.9 ~ 41.6										
	32LVSS5-□/20-53.0-e	3.0				12.2	129	126.0 ~ 51.6				
	32LVSS5-□/24-54.0-e	4.0				14.7	145	151.0 ~ 61.5				
	32LVSS5-□/29-54.0-e							182.2 ~ 73.7				
	32LVSS5-32/32-55.5-e	5.5				20.3	204	200.9 ~ 81.0				
	50	10				50LVSS10-□/2-5.75-e	0.75	3.4	26	80~230		19.8 ~ 9.6
			50LVSS10-□/3-51.1-e		1.1	4.7	34	29.8 ~ 15.1				
50LVSS10-□/4-51.5-e			1.5	6.2	47	39.8 ~ 20.7						
50LVSS10-□/5-52.2-e			2.2	8.7	83	49.8 ~ 26.2						
50LVSS10-□/6-52.2-e						59.7 ~ 31.4						
50LVSS10-□/8-53.0-e			3.0	12.2	129	79.6 ~ 41.8						
50LVSS10-□/10-54.0-e			4.0	14.7	145	99.5 ~ 52.1						
50LVSS10-□/12-54.0-e						119.4 ~ 62.4						
50LVSS10-□/14-55.5-e			5.5	20.3	204	139.3 ~ 72.7						
50LVSS10-□/16-55.5-e						159.1 ~ 82.9						
50LVSS10-□/18-57.5-e			7.5	27.2	290	179.0 ~ 93.2						
50LVSS10-□/20-57.5-e						198.9 ~ 103.3						
50LVSS10-22/22-57.5-e						218.7 ~ 113.5						
15			15	50LVSS15-□/1-51.1-e	1.1	4.7	34	140~400	12.7 ~ 5.8			
		50LVSS15-□/2-52.2-e		2.2	8.7	83	25.6 ~ 13.6					
		50LVSS15-□/3-53.0-e		3.0	12.2	129	38.6 ~ 21.4					
		50LVSS15-□/4-54.0-e		4.0	14.7	145	51.4 ~ 28.6					
		50LVSS15-□/5-54.0-e					64.3 ~ 35.7					
		50LVSS15-□/6-55.5-e		5.5	20.3	204	77.2 ~ 42.8					
		50LVSS15-□/7-55.5-e					90.0 ~ 49.9					
		50LVSS15-□/8-57.5-e		7.5	27.2	290	102.9 ~ 57.0					
		50LVSS15-□/9-57.5-e					115.7 ~ 64.1					
		50LVSS15-□/10-511-e		11	40.5	361	128.5 ~ 71.1					
		50LVSS15-□/12-511-e					154.2 ~ 85.2					
		50LVSS15-□/14-511-e		15	52.4	484	179.9 ~ 99.3					
		50LVSS15-17/17-515-e					218.4 ~ 120.4					
		20		20	50LVSS20-□/1-51.1-e	1.1	4.7		34	180~500	13.4 ~ 5.1	
					50LVSS20-□/2-52.2-e	2.2	8.7		83		27.1 ~ 12.8	
					50LVSS20-□/3-54.0-e	4.0	14.7		145		40.9 ~ 20.5	
					50LVSS20-□/4-55.5-e	5.5	20.3		204		54.6 ~ 27.3	
					50LVSS20-□/5-55.5-e						68.2 ~ 34.1	
50LVSS20-□/6-57.5-e			7.5		27.2	290	81.8 ~ 40.9					
50LVSS20-□/7-57.5-e	95.5 ~ 47.7											
50LVSS20-□/8-511-e	11		40.5		361	109.1 ~ 54.5						
50LVSS20-□/10-511-e						136.4 ~ 68.0						
50LVSS20-□/12-515-e	15		54.0		484	163.6 ~ 81.5						
50LVSS20-□/14-515-e						190.8 ~ 95.0						
50LVSS20-17/17-518-e	18.5		66.0		563	231.7 ~ 115.1						

Note) The rated current in the table above is the recommended setting for the current value of the protective device.



Specification table

60Hz

Bore diameter (mm)	Frequency (m <sup>3</sup> /h)	Type	Output (kW)	Rated voltage (V)	Rated current (A)	Starting current (A)	Discharge rate (L/min)	Total Head (m)		
32	1	32LVSS1-□/8-6.75-e	0.75	200/230	3.2/3.1	25/29	10~50	66.4 ~ 31.1		
		32LVSS1-□/10-61.1-e	1.1		4.4/4.1	32/37		82.9 ~ 38.2		
		32LVSS1-□/13-61.1-e			1.5	5.9/5.4		41/48	107.6 ~ 48.6	
		32LVSS1-□/15-61.5-e	2.2			8.4/7.6		78/83	123.9 ~ 55.4	
		32LVSS1-□/17-61.5-e			3.0	11.5/10.8		115/135	140.3 ~ 62.0	
		32LVSS1-□/21-62.2-e	4.0			14.3/12.8		132/151	172.8 ~ 74.8	
		32LVSS1-□/23-62.2-e			5.5	19.8/17.8		178/206	189.1 ~ 81.1	
		32LVSS1-□/25-62.2-e	7.5			26.5/23.7		254/295	205.3 ~ 87.2	
	32LVSS1-□/27-63.0-e	11			39.5/36.5	296/333	221.4 ~ 93.2			
	3		32LVSS3-□/5-6.75-e		0.75	200/230	3.2/3.1	25/29	20~90	42.7 ~ 16.7
		32LVSS3-□/6-61.1-e	1.1		4.4/4.1		32/37	51.2 ~ 20.0		
		32LVSS3-□/7-61.1-e			1.5		5.9/5.4	41/48		59.7 ~ 23.1
		32LVSS3-□/8-61.1-e	2.2				8.4/7.6	78/83		68.1 ~ 26.3
		32LVSS3-□/10-61.5-e			3.0		11.5/10.8	115/135		85.0 ~ 32.6
		32LVSS3-□/11-61.5-e	4.0				14.3/12.8	132/151		93.5 ~ 35.7
		32LVSS3-□/12-62.2-e			5.5		19.8/17.8	178/206		101.9 ~ 38.7
		32LVSS3-□/15-62.2-e	7.5				26.5/23.7	254/295		127.1 ~ 47.8
		32LVSS3-□/17-62.2-e			11		39.5/36.5	296/333		143.9 ~ 53.8
		32LVSS3-□/19-63.0-e	15				53.0/49.0	397/447		160.7 ~ 59.6
		32LVSS3-□/23-63.0-e			18.5		65.0/59.0	456/515		194.1 ~ 71.2
		32LVSS3-□/26-64.0-e	22.2				78.8/72.8	556/515		219.0 ~ 79.7
	5	32LVSS5-□/3-61.1-e			1.1	200/230	4.4/4.1	32/37	40~180	27.7 ~ 10.9
		32LVSS5-□/4-61.1-e	1.5		5.9/5.4		41/48	36.9 ~ 14.5		
		32LVSS5-□/5-61.5-e			2.2		8.4/7.6	78/83		46.1 ~ 18.1
		32LVSS5-□/6-62.2-e	3.0				11.5/10.8	115/135		55.3 ~ 21.6
		32LVSS5-□/7-62.2-e			4.0		14.3/12.8	132/151		64.4 ~ 25.2
		32LVSS5-□/8-62.2-e	5.5				19.8/17.8	178/206		73.6 ~ 28.7
		32LVSS5-□/10-63.0-e			7.5		26.5/23.7	254/295		92.0 ~ 35.7
		32LVSS5-□/12-63.0-e	11				39.5/36.5	296/333		110.3 ~ 42.6
		32LVSS5-□/14-64.0-e			15		53.0/49.0	397/447		128.6 ~ 49.5
		32LVSS5-□/16-64.0-e	18.5				65.0/59.0	456/515		146.9 ~ 56.4
		32LVSS5-□/20-65.5-e			22.2		78.8/72.8	556/515		183.4 ~ 69.9
32LVSS5-□/22-65.5-e		26.5	92.6/86.6	656/616			201.6 ~ 76.6			
32LVSS5-□/24-67.5-e	30		106.4/100.4	756/716	219.8 ~ 83.3					
10		50LVSS10-□/1-6.75-e	0.75	200/220	3.2/3.1	25/29	100~280	14.3 ~ 5.4		
	50LVSS10-□/2-61.5-e	1.5	5.9/5.4		41/48	28.9 ~ 13.2				
	50LVSS10-□/3-62.2-e		2.2		8.4/7.6	78/83		43.6 ~ 20.9		
	50LVSS10-□/4-63.0-e	3.0			11.5/10.8	115/135		58.2 ~ 28.7		
	50LVSS10-□/5-63.0-e		4.0		14.3/12.8	132/151		72.8 ~ 36.4		
	50LVSS10-□/6-64.0-e	5.5			19.8/17.8	178/206		87.4 ~ 43.6		
	50LVSS10-□/8-65.5-e		7.5		26.5/23.7	254/295		116.5 ~ 57.9		
	50LVSS10-□/9-65.5-e	11			39.5/36.5	296/333		131.0 ~ 65.1		
	50LVSS10-□/10-67.5-e		15		53.0/49.0	397/447		145.5 ~ 72.2		
	50LVSS10-□/12-67.5-e	18.5			65.0/59.0	456/515		174.6 ~ 86.5		
	50LVSS10-□/14-611-e		22.2		78.8/72.8	556/515		203.7 ~ 100.7		
	50LVSS10-□/16-611-e	26.5			92.6/86.6	656/616		232.7 ~ 114.8		
	50LVSS10-□/18-611-e		30		106.4/100.4	756/716		261.7 ~ 129.0		
	15	50LVSS15-□/1-61.5-e			1.5	200/230		5.9/5.4	41/48	160~450
50LVSS15-□/2-63.0-e		3.0	11.5/10.8	115/135	37.0 ~ 22.3					
50LVSS15-□/3-64.0-e			4.0	14.3/12.8	132/151		55.6 ~ 34.7			
50LVSS15-□/4-65.5-e		5.5		19.8/17.8	178/206		74.2 ~ 46.3			
50LVSS15-□/5-67.5-e			7.5	26.5/23.7	254/295		92.7 ~ 57.8			
50LVSS15-□/6-611-e		11		39.5/36.5	296/333		111.2 ~ 69.3			
50LVSS15-□/7-611-e			15	53.0/49.0	397/447		129.8 ~ 80.8			
50LVSS15-□/8-611-e		18.5		65.0/59.0	456/515		148.3 ~ 92.3			
50LVSS15-□/10-615-e			22.2	78.8/72.8	556/515		185.3 ~ 115.3			
50LVSS15-□/12-618-e		26.5		92.6/86.6	656/616		222.4 ~ 138.2			
20			50LVSS20-□/1-62.2-e	2.2	200/230		8.4/7.8	78/83	220~600	
		50LVSS20-□/2-64.0-e	4.0	14.3/12.8			132/151	39.0 ~ 18.3		
		50LVSS20-□/3-65.5-e		5.5			19.8/17.8	178/206		
		50LVSS20-□/4-67.5-e	7.5				26.5/23.7	254/295		
	50LVSS20-□/5-611-e	11		39.5/36.5		296/333	98.0 ~ 48.7			
	50LVSS20-□/6-611-e		15	53.0/49.0		397/447	117.6 ~ 58.4			
	50LVSS20-□/7-615-e	18.5		65.0/59.0		456/515	137.2 ~ 68.1			
	50LVSS20-□/8-615-e		22.2	78.8/72.8		556/515	156.8 ~ 77.7			
50LVSS20-□/10-618-e	26.5	92.6/86.6		656/616	195.9 ~ 97.0					

Note) The rated current in the table above is the recommended setting for the current value of the protective device.

Assembly drawing

● Discharge diameter: 32mm

Fig.1

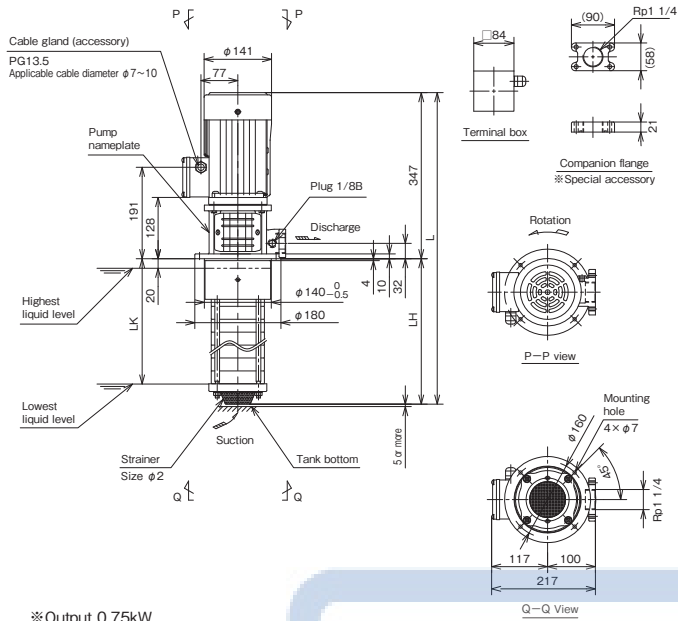

※ Output 0.75kW

Fig.2

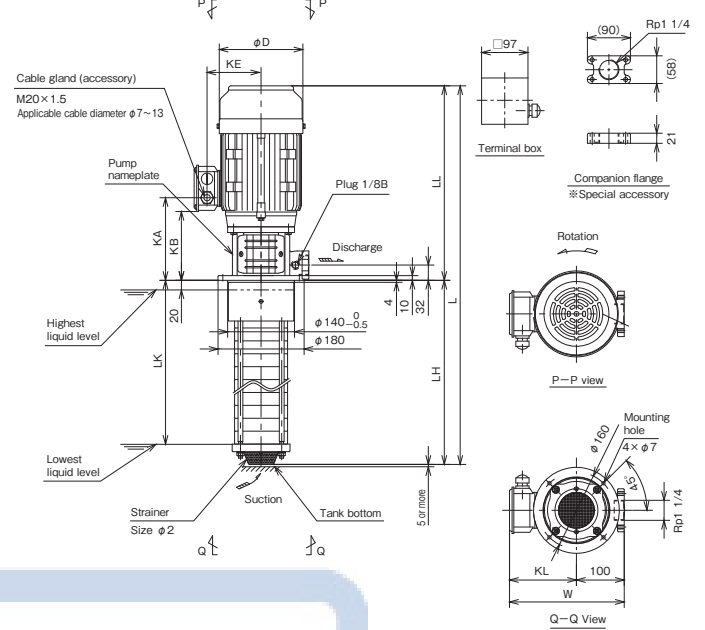

(Unit : mm)

Output kW	D	KA	KB	KE	KL	LL	W
1.1/1.5/2.2	175	173	144	113	140	407	240
3.0	196	183	154	125	152	432	252
4.0	219	178	149	134	161	437	—

Fig.3

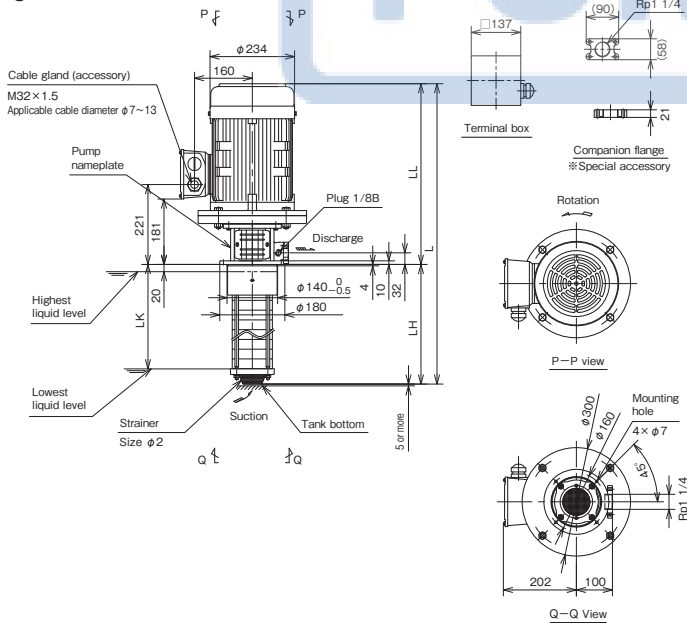

(Unit : mm)

Output kW	LL
5.5	500
7.5	535

Dimensions

● Discharge diameter: 32mm, Nominal flow rate: 1m<sup>3</sup>/h

50Hz

(Unit : mm)

Type	Fig.	L	LH	LK	Approx. mass(kg)
32LVSS1-13/13-5.75-e	1	696	349	307	23
32LVSS1-15/13-5.75-e		732	385	343	24
32LVSS1-17/13-5.75-e		768	421	379	24
32LVSS1-21/13-5.75-e		840	493	451	25
32LVSS1-25/13-5.75-e		912	565	523	26
32LVSS1-15/15-5.75-e		732	385	343	24
32LVSS1-17/15-5.75-e		768	421	379	24
32LVSS1-21/15-5.75-e		840	493	451	25
32LVSS1-25/15-5.75-e		912	565	523	26
32LVSS1-17/17-51.1-e		2	828	421	379
32LVSS1-21/17-51.1-e	900		493	451	29
32LVSS1-25/17-51.1-e	972		565	523	30
32LVSS1-30/17-51.1-e	1062		655	613	32
32LVSS1-21/21-51.1-e	900		493	451	30
32LVSS1-25/21-51.1-e	972		565	523	31
32LVSS1-30/21-51.1-e	1062		655	613	32
32LVSS1-33/21-51.1-e	1116		709	667	32
32LVSS1-23/23-51.1-e	936		529	487	30
32LVSS1-25/23-51.1-e	972		565	523	31
32LVSS1-30/23-51.1-e	1062		655	613	32
32LVSS1-33/23-51.1-e	1116		709	667	33
32LVSS1-36/23-51.1-e	1170		763	721	33
32LVSS1-27/27-51.5-e	1008		601	559	36
32LVSS1-33/27-51.5-e	1116		709	667	37
32LVSS1-36/27-51.5-e	1170		763	721	38
32LVSS1-30/30-51.5-e	1062		655	613	36
32LVSS1-33/30-51.5-e	1116		709	667	37
32LVSS1-36/30-51.5-e	1170		763	721	38
32LVSS1-33/33-52.2-e	1116		709	667	41
32LVSS1-36/33-52.2-e	1170		763	721	41
32LVSS1-36/36-52.2-e	1170		763	721	41

60Hz

(Unit : mm)

Type	Fig.	L	LH	LK	Approx. mass(kg)	
32LVSS1-8/8-6.75-e	1	606	259	217	22	
32LVSS1-10/8-6.75-e		642	295	253	22	
32LVSS1-13/8-6.75-e		696	349	307	23	
32LVSS1-15/8-6.75-e		732	385	343	24	
32LVSS1-17/8-6.75-e		768	421	379	24	
32LVSS1-21/8-6.75-e		840	493	451	25	
32LVSS1-25/8-6.75-e		912	565	523	26	
32LVSS1-10/10-61.1-e		2	702	295	253	27
32LVSS1-13/10-61.1-e			756	349	307	27
32LVSS1-15/10-61.1-e			792	385	343	28
32LVSS1-17/10-61.1-e	828		421	379	28	
32LVSS1-21/10-61.1-e	900		493	451	29	
32LVSS1-25/10-61.1-e	972		565	523	30	
32LVSS1-13/13-61.1-e	756		349	307	27	
32LVSS1-15/13-61.1-e	792		385	343	28	
32LVSS1-17/13-61.1-e	828		421	379	28	
32LVSS1-21/13-61.1-e	900		493	451	29	
32LVSS1-25/13-61.1-e	972		565	523	30	
32LVSS1-15/15-61.5-e	792		385	343	32	
32LVSS1-17/15-61.5-e	828		421	379	33	
32LVSS1-21/15-61.5-e	900		493	451	33	
32LVSS1-25/15-61.5-e	972		565	523	34	
32LVSS1-30/15-61.5-e	1062		655	613	36	
32LVSS1-17/17-61.5-e	828		421	379	33	
32LVSS1-21/17-61.5-e	900		493	451	34	
32LVSS1-25/17-61.5-e	972		565	523	35	
32LVSS1-30/17-61.5-e	1062		655	613	36	
32LVSS1-33/17-61.5-e	1116		709	667	36	
32LVSS1-21/21-62.2-e	900		493	451	37	
32LVSS1-25/21-62.2-e	972		565	523	38	
32LVSS1-30/21-62.2-e	1062		655	613	39	
32LVSS1-33/21-62.2-e	1116		709	667	40	
32LVSS1-36/21-62.2-e	1170		763	721	41	
32LVSS1-23/23-62.2-e	936		529	487	38	
32LVSS1-27/23-62.2-e	1008		601	559	39	
32LVSS1-30/23-62.2-e	1062		655	613	39	
32LVSS1-33/23-62.2-e	1116		709	667	40	
32LVSS1-36/23-62.2-e	1170		763	721	41	
32LVSS1-25/25-62.2-e	972		565	523	38	
32LVSS1-27/25-62.2-e	1008	601	559	39		
32LVSS1-30/25-62.2-e	1062	655	613	40		
32LVSS1-33/25-62.2-e	1116	709	667	40		
32LVSS1-36/25-62.2-e	1170	763	721	41		
32LVSS1-27/27-63.0-e	1033	601	559	46		
32LVSS1-30/27-63.0-e	1087	655	613	47		
32LVSS1-33/27-63.0-e	1141	709	667	47		
32LVSS1-36/27-63.0-e	1195	763	721	48		

●Discharge diameter: 32mm, Nominal flow rate: 3m<sup>3</sup>/h

50Hz

(Unit : mm)

Type	Fig.	L	LH	LK	Approx. mass(kg)
32LVSS3-10/10-5.75-e	1	642	295	253	22
32LVSS3-12/10-5.75-e		678	331	289	23
32LVSS3-15/10-5.75-e		732	385	343	24
32LVSS3-19/10-5.75-e		804	457	415	25
32LVSS3-23/10-5.75-e		876	529	487	25
32LVSS3-12/12-51.1-e	2	738	331	289	27
32LVSS3-15/12-51.1-e		792	385	343	28
32LVSS3-19/12-51.1-e		864	457	415	29
32LVSS3-23/12-51.1-e		936	529	487	30
32LVSS3-15/15-51.1-e		792	385	343	28
32LVSS3-19/15-51.1-e		864	457	415	29
32LVSS3-23/15-51.1-e		936	529	487	30
32LVSS3-17/17-51.5-e		828	421	379	33
32LVSS3-23/17-51.5-e		936	529	487	34
32LVSS3-26/17-51.5-e		990	583	541	35
32LVSS3-19/19-51.5-e		864	457	415	33
32LVSS3-23/19-51.5-e		936	529	487	34
32LVSS3-26/19-51.5-e		990	583	541	35
32LVSS3-30/19-51.5-e		1062	655	613	36
32LVSS3-25/25-52.2-e		972	565	523	38
32LVSS3-30/25-52.2-e		1062	655	613	40
32LVSS3-36/25-52.2-e		1170	763	721	41
32LVSS3-30/30-53.0-e		1087	655	613	47
32LVSS3-36/30-53.0-e		1195	763	721	48
32LVSS3-36/36-53.0-e		1195	763	721	48

60Hz

(Unit : mm)

Type	Fig.	L	LH	LK	Approx. mass(kg)
32LVSS3-5/5-6.75-e	1	552	205	163	21
32LVSS3-7/5-6.75-e		588	241	199	21
32LVSS3-10/5-6.75-e		642	295	253	22
32LVSS3-12/5-6.75-e		678	331	289	23
32LVSS3-15/5-6.75-e		732	385	343	23
32LVSS3-19/5-6.75-e		804	457	415	24
32LVSS3-23/5-6.75-e		876	529	487	25
32LVSS3-6/6-61.1-e		630	223	181	25
32LVSS3-10/6-61.1-e		702	295	253	26
32LVSS3-12/6-61.1-e		738	331	289	27
32LVSS3-15/6-61.1-e		792	385	343	28
32LVSS3-19/6-61.1-e		864	457	415	28
32LVSS3-23/6-61.1-e		936	529	487	29
32LVSS3-7/7-61.1-e		648	241	199	26
32LVSS3-10/7-61.1-e		702	295	253	26
32LVSS3-12/7-61.1-e	738	331	289	27	
32LVSS3-15/7-61.1-e	792	385	343	28	
32LVSS3-19/7-61.1-e	864	457	415	28	
32LVSS3-23/7-61.1-e	936	529	487	29	
32LVSS3-8/8-61.1-e	666	259	217	26	
32LVSS3-10/8-61.1-e	702	295	253	26	
32LVSS3-12/8-61.1-e	738	331	289	27	
32LVSS3-15/8-61.1-e	792	385	343	28	
32LVSS3-19/8-61.1-e	864	457	415	29	
32LVSS3-23/8-61.1-e	936	529	487	29	
32LVSS3-10/10-61.5-e	702	295	253	31	
32LVSS3-12/10-61.5-e	738	331	289	31	
32LVSS3-15/10-61.5-e	792	385	343	32	
32LVSS3-19/10-61.5-e	864	457	415	33	
32LVSS3-23/10-61.5-e	936	529	487	34	
32LVSS3-11/11-61.5-e	720	313	271	31	
32LVSS3-15/11-61.5-e	792	385	343	32	
32LVSS3-19/11-61.5-e	864	457	415	33	
32LVSS3-23/11-61.5-e	936	529	487	34	
32LVSS3-12/12-62.2-e	738	331	289	35	
32LVSS3-15/12-62.2-e	792	385	343	35	
32LVSS3-19/12-62.2-e	864	457	415	36	
32LVSS3-23/12-62.2-e	936	529	487	37	
32LVSS3-15/15-62.2-e	792	385	343	36	
32LVSS3-19/15-62.2-e	864	457	415	36	
32LVSS3-23/15-62.2-e	936	529	487	37	
32LVSS3-26/15-62.2-e	990	583	541	38	
32LVSS3-17/17-62.2-e	828	421	379	36	
32LVSS3-23/17-62.2-e	936	529	487	37	
32LVSS3-26/17-62.2-e	990	583	541	38	
32LVSS3-30/17-62.2-e	1062	655	613	39	
32LVSS3-19/19-63.0-e	889	457	415	44	
32LVSS3-23/19-63.0-e	961	529	487	44	
32LVSS3-26/19-63.0-e	1015	583	541	45	
32LVSS3-30/19-63.0-e	1087	655	613	46	
32LVSS3-36/19-63.0-e	1195	763	721	47	
32LVSS3-23/23-63.0-e	961	529	487	45	
32LVSS3-26/23-63.0-e	1015	583	541	45	
32LVSS3-30/23-63.0-e	1087	655	613	46	
32LVSS3-36/23-63.0-e	1195	763	721	48	
32LVSS3-26/26-64.0-e	1020	583	541	51	
32LVSS3-30/26-64.0-e	1092	655	613	52	
32LVSS3-36/26-64.0-e	1200	763	721	53	

●Discharge diameter: 32mm, Nominal flow rate: 5m<sup>3</sup>/h

50Hz

(Unit : mm)

Type	Fig.	L	LH	LK	Approx. mass(kg)
32LVSS5-5/5-5.75-e	1	597	250	208	22
32LVSS5-7/5-5.75-e		651	304	262	22
32LVSS5-10/5-5.75-e		732	385	343	23
32LVSS5-14/5-5.75-e		840	493	451	24
32LVSS5-16/5-5.75-e		894	547	505	25
32LVSS5-20/5-5.75-e		1002	655	613	26
32LVSS5-8/8-51.1-e	2	738	331	289	27
32LVSS5-10/8-51.1-e		792	385	343	27
32LVSS5-14/8-51.1-e		900	493	451	29
32LVSS5-16/8-51.1-e		954	547	505	29
32LVSS5-20/8-51.1-e		1062	655	613	31
32LVSS5-10/10-51.5-e		792	385	343	32
32LVSS5-14/10-51.5-e		900	493	451	33
32LVSS5-16/10-51.5-e		954	547	505	34
32LVSS5-20/10-51.5-e		1062	655	613	35
32LVSS5-14/14-52.2-e		900	493	451	37
32LVSS5-16/14-52.2-e		954	547	505	37
32LVSS5-20/14-52.2-e		1062	655	613	39
32LVSS5-24/14-52.2-e		1170	763	721	40
32LVSS5-16/16-52.2-e		954	547	505	37
32LVSS5-20/16-52.2-e		1062	655	613	39
32LVSS5-24/16-52.2-e		1170	763	721	40
32LVSS5-29/16-52.2-e		1305	898	856	41
32LVSS5-20/20-53.0-e		1087	655	613	46
32LVSS5-24/20-53.0-e		1195	763	721	47
32LVSS5-29/20-53.0-e		1330	898	856	49
32LVSS5-32/20-53.0-e		1411	979	937	50
32LVSS5-24/24-54.0-e		1200	763	721	53
32LVSS5-29/24-54.0-e		1335	898	856	54
32LVSS5-32/24-54.0-e		1416	979	937	55
32LVSS5-29/29-54.0-e		1335	898	856	54
32LVSS5-32/29-54.0-e		1416	979	937	55
32LVSS5-32/32-55.5-e		3	1479	979	937

60Hz

(Unit : mm)

Type	Fig.	L	LH	LK	Approx. mass(kg)
32LVSS5-3/3-61.1-e	2	603	196	154	25
32LVSS5-5/3-61.1-e		657	250	208	26
32LVSS5-7/3-61.1-e		711	304	262	26
32LVSS5-10/3-61.1-e		792	385	343	27
32LVSS5-14/3-61.1-e		900	493	451	28
32LVSS5-16/3-61.1-e		954	547	505	29
32LVSS5-20/3-61.1-e		1062	655	613	30
32LVSS5-4/4-61.1-e		630	223	181	25
32LVSS5-6/4-61.1-e		684	277	235	26
32LVSS5-8/4-61.1-e		738	331	289	26
32LVSS5-10/4-61.1-e		792	385	343	27
32LVSS5-14/4-61.1-e		900	493	451	29
32LVSS5-16/4-61.1-e		954	547	505	30
32LVSS5-20/4-61.1-e		1062	655	613	31
32LVSS5-5/5-61.5-e		657	250	208	30
32LVSS5-7/5-61.5-e		711	304	262	30
32LVSS5-10/5-61.5-e		792	385	343	31
32LVSS5-14/5-61.5-e		900	493	451	33
32LVSS5-16/5-61.5-e		954	547	505	33
32LVSS5-20/5-61.5-e		1062	655	613	35
32LVSS5-6/6-62.2-e		684	277	235	34
32LVSS5-8/6-62.2-e		738	331	289	34
32LVSS5-10/6-62.2-e		792	385	343	35
32LVSS5-14/6-62.2-e		900	493	451	36
32LVSS5-16/6-62.2-e	954	547	505	37	
32LVSS5-20/6-62.2-e	1062	655	613	38	
32LVSS5-14/6-62.2-e	900	493	451	36	
32LVSS5-16/6-62.2-e	954	547	505	37	
32LVSS5-20/6-62.2-e	1062	655	613	38	
32LVSS5-16/6-62.2-e	954	547	505	37	
32LVSS5-7/7-62.2-e	711	304	262	34	
32LVSS5-10/7-62.2-e	792	385	343	35	
32LVSS5-14/7-62.2-e	900	493	451	36	
32LVSS5-16/7-62.2-e	954	547	505	37	
32LVSS5-20/7-62.2-e	1062	655	613	38	
32LVSS5-8/8-62.2-e	738	331	289	34	
32LVSS5-10/8-62.2-e	792	385	343	35	
32LVSS5-14/8-62.2-e	900	493	451	36	
32LVSS5-16/8-62.2-e	954	547	505	37	
32LVSS5-20/8-62.2-e	1062	655	613	38	
32LVSS5-10/10-63.0-e	817	385	343	42	
32LVSS5-14/10-63.0-e	925	493	451	43	
32LVSS5-16/10-63.0-e	979	547	505	44	
32LVSS5-20/10-63.0-e	1087	655	613	45	
32LVSS5-12/12-63.0-e	871	439	397	43	
32LVSS5-14/12-63.0-e	925	493	451	43	
32LVSS5-16/12-63.0-e	979	547	505	44	
32LVSS5-20/12-63.0-e	1087	655	613	45	
32LVSS5-24/12-63.0-e	1195	763	721	46	
32LVSS5-14/14-64.0-e	930	493	451	49	
32LVSS5-16/14-64.0-e	984	547	505	50	
32LVSS5-20/14-64.0-e	1092	655	613	51	
32LVSS5-24/14-64.0-e	1200	763	721	52	
32LVSS5-29/14-64.0-e	1335	898	856	54	
32LVSS5-16/16-64.0-e	984	547	505	50	
32LVSS5-20/16-64.0-e	1092	655	613	51	
32LVSS5-24/16-64.0-e	1200	763	721	52	
32LVSS5-29/16-64.0-e	1335	898	856	54	
32LVSS5-32/16-64.0-e	1416	979	937	55	
32LVSS5-20/20-65.5-e	3	1155	655	613	79
32LVSS5-24/20-65.5-e		1263	763	721	80
32LVSS5-29/20-65.5-e		1398	898	856	81
32LVSS5-32/20-65.5-e		1479	979	937	82
32LVSS5-22/22-65.5-e		1209	709	667	79
32LVSS5-24/22-65.5-e		1263	763	721	80
32LVSS5-29/22-65.5-e		1398	898	856	81
32LVSS5-32/22-65.5-e		1479	979	937	82
32LVSS5-24/24-67.5-e		1298	763	721	87
32LVSS5-29/24-67.5-e		1433	898	856	88
32LVSS5-32/24-67.5-e		1514	979	937	89

Assembly drawing

● Discharge diameter: 50mm

Fig.1

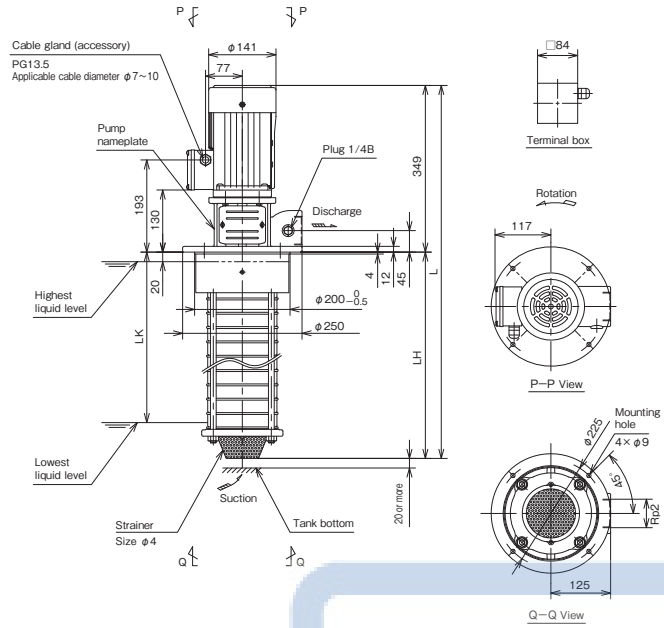
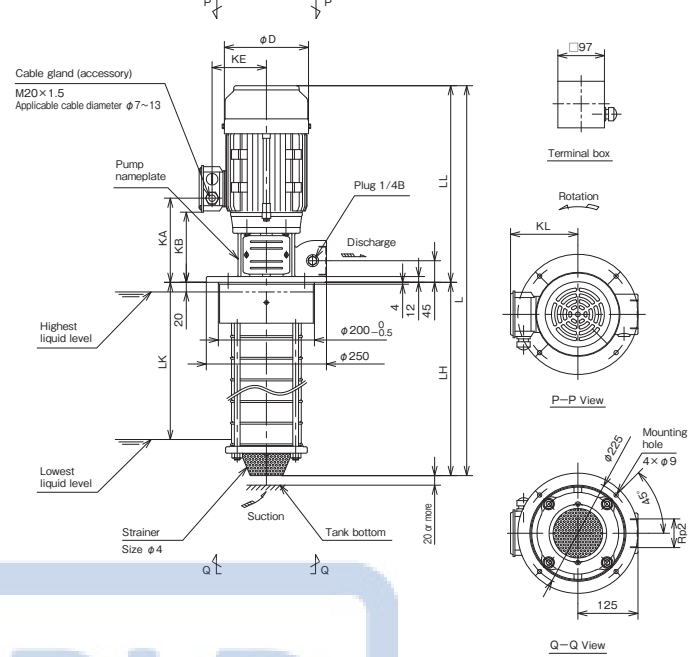

Fig.2



※ Output 0.75kW

(Unit : mm)

Output kW	D	KA	KB	KE	KL	LL
1.1/1.5/2.2	175	175	146	113	140	409
3.0	196	185	156	125	152	444
4.0	219	190	161	134	161	449

Fig.3

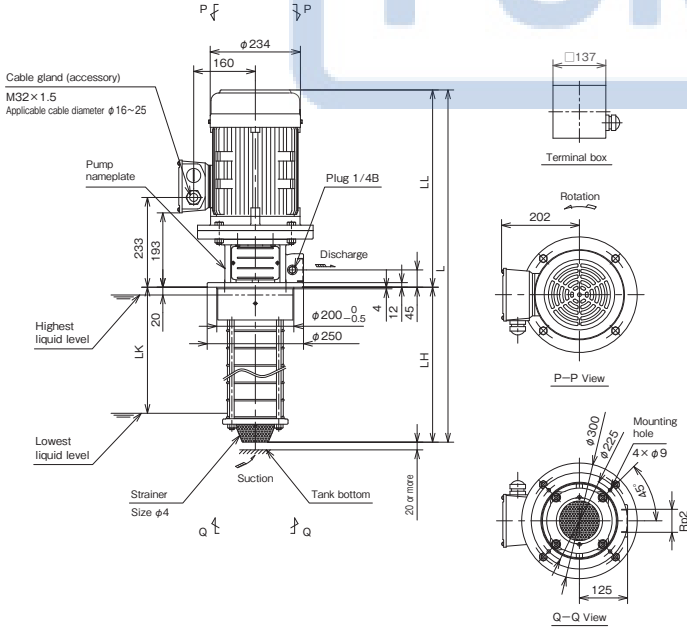
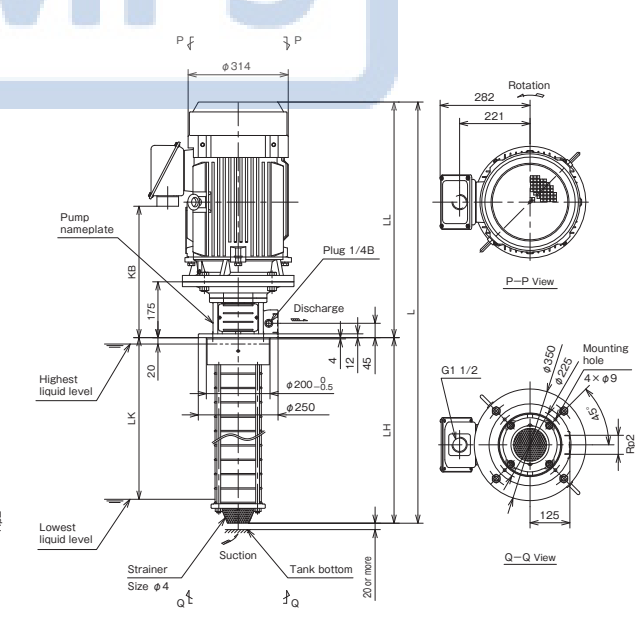

Fig.4



(Unit : mm)

Output kW	LL
5.5	512
7.5	547

(Unit : mm)

Output kW	KB	LL
11/15	382	709
18.5	412	739

Dimensions

● Discharge diameter: 50mm, Nominal flow rate: 10m<sup>3</sup>/h

50Hz

(Unit : mm)

(Unit : mm)

Type	Fig.	L	LH	LK	Approx. mass(kg)
50LVSS10-5/2-5.75-e	1	631	282	207	30
50LVSS10-6/2-5.75-e		661	312	237	30
50LVSS10-8/2-5.75-e		721	372	297	32
50LVSS10-10/2-5.75-e		781	432	357	33
50LVSS10-12/2-5.75-e		841	492	417	34
50LVSS10-14/2-5.75-e		901	552	477	36
50LVSS10-16/2-5.75-e		961	612	537	37
50LVSS10-18/2-5.75-e		1021	672	597	38
50LVSS10-20/2-5.75-e		1081	732	657	40
50LVSS10-22/2-5.75-e		1141	792	717	41
50LVSS10-5/3-51.1-e	2	691	282	207	34
50LVSS10-6/3-51.1-e		721	312	237	35
50LVSS10-8/3-51.1-e		781	372	297	36
50LVSS10-10/3-51.1-e		841	432	357	37
50LVSS10-12/3-51.1-e		901	492	417	39
50LVSS10-14/3-51.1-e		961	552	477	40
50LVSS10-16/3-51.1-e		1021	612	537	41
50LVSS10-18/3-51.1-e		1081	672	597	42
50LVSS10-20/3-51.1-e		1141	732	657	44
50LVSS10-22/3-51.1-e		1201	792	717	45
50LVSS10-5/4-51.5-e		691	282	207	38
50LVSS10-6/4-51.5-e		721	312	237	38
50LVSS10-8/4-51.5-e		781	372	297	40
50LVSS10-10/4-51.5-e		841	432	357	41
50LVSS10-12/4-51.5-e		901	492	417	42
50LVSS10-14/4-51.5-e		961	552	477	44
50LVSS10-16/4-51.5-e		1021	612	537	45
50LVSS10-18/4-51.5-e		1081	672	597	46
50LVSS10-20/4-51.5-e		1141	732	657	48
50LVSS10-22/4-51.5-e		1201	792	717	49
50LVSS10-5/5-52.2-e		691	282	207	41
50LVSS10-6/5-52.2-e		721	312	237	42
50LVSS10-8/5-52.2-e		781	372	297	43
50LVSS10-10/5-52.2-e		841	432	357	45
50LVSS10-12/5-52.2-e		901	492	417	46
50LVSS10-14/5-52.2-e		961	552	477	47
50LVSS10-16/5-52.2-e		1021	612	537	49
50LVSS10-18/5-52.2-e		1081	672	597	50
50LVSS10-20/5-52.2-e		1141	732	657	51
50LVSS10-22/5-52.2-e		1201	792	717	53
50LVSS10-6/6-52.2-e	721	312	237	42	
50LVSS10-8/6-52.2-e	781	372	297	43	
50LVSS10-10/6-52.2-e	841	432	357	45	
50LVSS10-12/6-52.2-e	901	492	417	46	
50LVSS10-14/6-52.2-e	961	552	477	47	
50LVSS10-16/6-52.2-e	1021	612	537	49	
50LVSS10-18/6-52.2-e	1081	672	597	50	
50LVSS10-20/6-52.2-e	1141	732	657	51	
50LVSS10-22/6-52.2-e	1201	792	717	53	

Type	Fig.	L	LH	LK	Approx. mass(kg)
50LVSS10-8/8-53.0-e	2	816	372	297	52
50LVSS10-10/8-53.0-e		876	432	357	53
50LVSS10-12/8-53.0-e		936	492	417	54
50LVSS10-14/8-53.0-e		996	552	477	56
50LVSS10-16/8-53.0-e		1056	612	537	57
50LVSS10-18/8-53.0-e		1116	672	597	58
50LVSS10-20/8-53.0-e		1176	732	657	60
50LVSS10-22/8-53.0-e		1236	792	717	61
50LVSS10-10/10-54.0-e		881	432	357	59
50LVSS10-12/10-54.0-e		941	492	417	60
50LVSS10-14/10-54.0-e	1001	552	477	61	
50LVSS10-16/10-54.0-e	1061	612	537	63	
50LVSS10-18/10-54.0-e	1121	672	597	64	
50LVSS10-20/10-54.0-e	1181	732	657	65	
50LVSS10-22/10-54.0-e	1241	792	717	67	
50LVSS10-12/12-54.0-e	941	492	417	60	
50LVSS10-14/12-54.0-e	1001	552	477	61	
50LVSS10-16/12-54.0-e	1061	612	537	63	
50LVSS10-18/12-54.0-e	1121	672	597	64	
50LVSS10-20/12-54.0-e	1181	732	657	65	
50LVSS10-22/12-54.0-e	1241	792	717	67	
50LVSS10-14/14-55.5-e	1064	552	477	89	
50LVSS10-16/14-55.5-e	1124	612	537	90	
50LVSS10-18/14-55.5-e	1184	672	597	92	
50LVSS10-20/14-55.5-e	1244	732	657	93	
50LVSS10-22/14-55.5-e	1304	792	717	94	
50LVSS10-16/16-55.5-e	1124	612	537	91	
50LVSS10-18/16-55.5-e	1184	672	597	92	
50LVSS10-20/16-55.5-e	1244	732	657	93	
50LVSS10-22/16-55.5-e	1304	792	717	94	
50LVSS10-18/18-57.5-e	1219	672	597	99	
50LVSS10-20/18-57.5-e	1279	732	657	100	
50LVSS10-22/18-57.5-e	1339	792	717	101	
50LVSS10-20/20-57.5-e	1279	732	657	100	
50LVSS10-22/20-57.5-e	1339	792	717	101	
50LVSS10-22/22-57.5-e	1339	792	717	102	

●Discharge diameter: 50mm, Nominal flow rate: 10m<sup>3</sup>/h

60Hz

(Unit : mm)

(Unit : mm)

Type	Fig.	L	LH	LK	Approx. mass(kg)
50LVSS10-5/1-6.75-e	1	631	282	207	30
50LVSS10-6/1-6.75-e		661	312	237	30
50LVSS10-8/1-6.75-e		721	372	297	32
50LVSS10-10/1-6.75-e		781	432	357	33
50LVSS10-12/1-6.75-e		841	492	417	34
50LVSS10-5/2-61.5-e	2	691	282	207	38
50LVSS10-6/2-61.5-e		721	312	237	38
50LVSS10-8/2-61.5-e		781	372	297	40
50LVSS10-10/2-61.5-e		841	432	357	41
50LVSS10-12/2-61.5-e		901	492	417	42
50LVSS10-14/2-61.5-e		961	552	477	44
50LVSS10-16/2-61.5-e		1021	612	537	45
50LVSS10-18/2-61.5-e		1081	672	597	46
50LVSS10-20/2-61.5-e		1141	732	657	48
50LVSS10-22/2-61.5-e		1201	792	717	49
50LVSS10-5/3-62.2-e		691	282	207	41
50LVSS10-6/3-62.2-e		721	312	237	42
50LVSS10-8/3-62.2-e		781	372	297	43
50LVSS10-10/3-62.2-e		841	432	357	44
50LVSS10-12/3-62.2-e		901	492	417	46
50LVSS10-14/3-62.2-e		961	552	477	47
50LVSS10-16/3-62.2-e		1021	612	537	48
50LVSS10-18/3-62.2-e		1081	672	597	50
50LVSS10-20/3-62.2-e		1141	732	657	51
50LVSS10-22/3-62.2-e		1201	792	717	52
50LVSS10-5/4-63.0-e		726	282	207	49
50LVSS10-6/4-63.0-e		756	312	237	50
50LVSS10-8/4-63.0-e		816	372	297	51
50LVSS10-10/4-63.0-e		876	432	357	53
50LVSS10-12/4-63.0-e		936	492	417	54
50LVSS10-14/4-63.0-e	996	552	477	55	
50LVSS10-16/4-63.0-e	1056	612	537	57	
50LVSS10-18/4-63.0-e	1116	672	597	58	
50LVSS10-20/4-63.0-e	1176	732	657	59	
50LVSS10-22/4-63.0-e	1236	792	717	61	
50LVSS10-5/5-63.0-e	726	282	207	49	
50LVSS10-6/5-63.0-e	756	312	237	50	
50LVSS10-8/5-63.0-e	816	372	297	51	
50LVSS10-10/5-63.0-e	876	432	357	53	
50LVSS10-12/5-63.0-e	936	492	417	54	
50LVSS10-14/5-63.0-e	996	552	477	55	
50LVSS10-16/5-63.0-e	1056	612	537	57	
50LVSS10-18/5-63.0-e	1116	672	597	58	
50LVSS10-20/5-63.0-e	1176	732	657	59	
50LVSS10-22/5-63.0-e	1236	792	717	61	
50LVSS10-6/6-64.0-e	761	312	237	56	
50LVSS10-8/6-64.0-e	821	372	297	57	
50LVSS10-10/6-64.0-e	881	432	357	58	
50LVSS10-12/6-64.0-e	941	492	417	60	
50LVSS10-14/6-64.0-e	1001	552	477	61	
50LVSS10-16/6-64.0-e	1061	612	537	62	
50LVSS10-18/6-64.0-e	1121	672	597	64	
50LVSS10-20/6-64.0-e	1181	732	657	65	
50LVSS10-22/6-64.0-e	1241	792	717	66	

Type	Fig.	L	LH	LK	Approx. mass(kg)
50LVSS10-8/8-65.5-e	3	884	372	297	84
50LVSS10-10/8-65.5-e		944	432	357	86
50LVSS10-12/8-65.5-e		1004	492	417	87
50LVSS10-14/8-65.5-e		1064	552	477	88
50LVSS10-16/8-65.5-e		1124	612	537	90
50LVSS10-18/8-65.5-e		1184	672	597	91
50LVSS10-20/8-65.5-e		1244	732	657	92
50LVSS10-22/8-65.5-e		1304	792	717	94
50LVSS10-9/9-65.5-e		914	402	327	85
50LVSS10-12/9-65.5-e		1004	492	417	87
50LVSS10-14/9-65.5-e		1064	552	477	89
50LVSS10-16/9-65.5-e		1124	612	537	90
50LVSS10-18/9-65.5-e		1184	672	597	91
50LVSS10-20/9-65.5-e		1244	732	657	92
50LVSS10-22/9-65.5-e		1304	792	717	94
50LVSS10-10/10-67.5-e		979	432	357	93
50LVSS10-12/10-67.5-e		1039	492	417	94
50LVSS10-14/10-67.5-e		1099	552	477	95
50LVSS10-16/10-67.5-e		1159	612	537	97
50LVSS10-18/10-67.5-e		1219	672	597	98
50LVSS10-20/10-67.5-e		1279	732	657	99
50LVSS10-22/10-67.5-e		1339	792	717	101
50LVSS10-12/12-67.5-e		1039	492	417	94
50LVSS10-14/12-67.5-e		1099	552	477	95
50LVSS10-16/12-67.5-e		1159	612	537	97
50LVSS10-18/12-67.5-e	1219	672	597	98	
50LVSS10-20/12-67.5-e	1279	732	657	99	
50LVSS10-22/12-67.5-e	1339	792	717	101	
50LVSS10-14/14-611-e	4	1267	552	477	176
50LVSS10-16/14-611-e		1327	612	537	177
50LVSS10-18/14-611-e		1387	672	597	179
50LVSS10-20/14-611-e		1447	732	657	180
50LVSS10-22/14-611-e		1507	792	717	181
50LVSS10-16/16-611-e		1327	612	537	177
50LVSS10-18/16-611-e		1387	672	597	179
50LVSS10-20/16-611-e		1447	732	657	180
50LVSS10-22/16-611-e		1507	792	717	181
50LVSS10-18/18-611-e		1387	672	597	179
50LVSS10-20/18-611-e		1447	732	657	180
50LVSS10-22/18-611-e		1507	792	717	182



●Discharge diameter: 50mm, Nominal flow rate: 15m<sup>3</sup>/h

50Hz

(Unit : mm)

Type	Fig.	L	LH	LK	Approx. mass(kg)
50LVSS15-3/1-51.1-e	2	676	267	192	33
50LVSS15-4/1-51.1-e		721	312	237	34
50LVSS15-5/1-51.1-e		766	357	282	35
50LVSS15-6/1-51.1-e		811	402	327	36
50LVSS15-7/1-51.1-e		856	447	372	37
50LVSS15-8/1-51.1-e		901	492	417	38
50LVSS15-3/2-52.2-e		676	267	192	41
50LVSS15-4/2-52.2-e		721	312	237	41
50LVSS15-5/2-52.2-e		766	357	282	42
50LVSS15-6/2-52.2-e		811	402	327	43
50LVSS15-7/2-52.2-e		856	447	372	44
50LVSS15-8/2-52.2-e		901	492	417	45
50LVSS15-10/2-52.2-e		991	582	507	46
50LVSS15-12/2-52.2-e		1081	672	597	48
50LVSS15-14/2-52.2-e		1171	762	687	50
50LVSS15-3/3-53.0-e		711	267	192	49
50LVSS15-4/3-53.0-e		756	312	237	49
50LVSS15-5/3-53.0-e		801	357	282	50
50LVSS15-6/3-53.0-e		846	402	327	51
50LVSS15-7/3-53.0-e		891	447	372	52
50LVSS15-8/3-53.0-e		936	492	417	53
50LVSS15-10/3-53.0-e		1026	582	507	55
50LVSS15-12/3-53.0-e		1116	672	597	56
50LVSS15-14/3-53.0-e		1206	762	687	58
50LVSS15-17/3-53.0-e		1341	897	822	60
50LVSS15-4/4-54.0-e		761	312	237	55
50LVSS15-5/4-54.0-e		806	357	282	56
50LVSS15-6/4-54.0-e		851	402	327	57
50LVSS15-7/4-54.0-e		896	447	372	58
50LVSS15-8/4-54.0-e		941	492	417	59
50LVSS15-10/4-54.0-e		1031	582	507	60
50LVSS15-12/4-54.0-e		1121	672	597	62
50LVSS15-14/4-54.0-e		1211	762	687	64
50LVSS15-17/4-54.0-e		1346	897	822	66
50LVSS15-5/5-54.0-e		806	357	282	56
50LVSS15-6/5-54.0-e		851	402	327	57
50LVSS15-7/5-54.0-e		896	447	372	58
50LVSS15-8/5-54.0-e		941	492	417	59
50LVSS15-10/5-54.0-e		1031	582	507	60
50LVSS15-12/5-54.0-e		1121	672	597	62
50LVSS15-14/5-54.0-e		1211	762	687	64
50LVSS15-17/5-54.0-e		1346	897	822	66
50LVSS15-6/6-55.5-e		914	402	327	85
50LVSS15-7/6-55.5-e		959	447	372	85
50LVSS15-8/6-55.5-e		1004	492	417	86
50LVSS15-10/6-55.5-e	1094	582	507	88	
50LVSS15-12/6-55.5-e	1184	672	597	90	
50LVSS15-14/6-55.5-e	1274	762	687	91	
50LVSS15-17/6-55.5-e	1409	897	822	94	
50LVSS15-7/7-55.5-e	959	447	372	86	
50LVSS15-8/7-55.5-e	1004	492	417	86	
50LVSS15-10/7-55.5-e	1094	582	507	88	
50LVSS15-12/7-55.5-e	1184	672	597	90	
50LVSS15-14/7-55.5-e	1274	762	687	91	
50LVSS15-17/7-55.5-e	1409	897	822	94	
50LVSS15-8/8-57.5-e	1039	492	417	93	
50LVSS15-10/8-57.5-e	1129	582	507	95	
50LVSS15-12/8-57.5-e	1219	672	597	97	
50LVSS15-14/8-57.5-e	1309	762	687	98	
50LVSS15-17/8-57.5-e	1444	897	822	101	
50LVSS15-9/9-57.5-e	1084	537	462	94	
50LVSS15-12/9-57.5-e	1219	672	597	97	
50LVSS15-14/9-57.5-e	1309	762	687	98	
50LVSS15-17/9-57.5-e	1444	897	822	101	
50LVSS15-10/10-511-e	1297	582	507	176	
50LVSS15-12/10-511-e	1387	672	597	177	
50LVSS15-14/10-511-e	1477	762	687	179	
50LVSS15-17/10-511-e	1612	897	822	181	
50LVSS15-12/12-511-e	1387	672	597	178	
50LVSS15-14/12-511-e	1477	762	687	179	
50LVSS15-17/12-511-e	1612	897	822	182	
50LVSS15-14/14-511-e	1477	762	687	180	
50LVSS15-17/14-511-e	1612	897	822	182	
50LVSS15-17/17-515-e	1612	897	822	183	

60Hz

(Unit : mm)

Type	Fig.	L	LH	LK	Approx. mass(kg)
50LVSS15-3/1-61.5-e	2	676	267	192	37
50LVSS15-4/1-61.5-e		721	312	237	38
50LVSS15-5/1-61.5-e		766	357	282	39
50LVSS15-6/1-61.5-e		811	402	327	40
50LVSS15-7/1-61.5-e		856	447	372	40
50LVSS15-8/1-61.5-e		901	492	417	41
50LVSS15-10/1-61.5-e		991	582	507	43
50LVSS15-3/2-63.0-e		711	267	192	49
50LVSS15-4/2-63.0-e		756	312	237	49
50LVSS15-5/2-63.0-e		801	357	282	50
50LVSS15-6/2-63.0-e		846	402	327	51
50LVSS15-7/2-63.0-e		891	447	372	52
50LVSS15-8/2-63.0-e		936	492	417	53
50LVSS15-10/2-63.0-e		1026	582	507	55
50LVSS15-12/2-63.0-e		1116	672	597	56
50LVSS15-14/2-63.0-e		1206	762	687	58
50LVSS15-17/2-63.0-e		1341	897	822	60
50LVSS15-3/3-64.0-e		716	267	192	54
50LVSS15-4/3-64.0-e		761	312	237	55
50LVSS15-5/3-64.0-e		806	357	282	56
50LVSS15-6/3-64.0-e		851	402	327	57
50LVSS15-7/3-64.0-e		896	447	372	57
50LVSS15-8/3-64.0-e		941	492	417	58
50LVSS15-10/3-64.0-e		1031	582	507	60
50LVSS15-12/3-64.0-e		1121	672	597	62
50LVSS15-14/3-64.0-e		1211	762	687	63
50LVSS15-17/3-64.0-e		1346	897	822	66
50LVSS15-4/4-65.5-e		824	312	237	82
50LVSS15-5/4-65.5-e		869	357	282	83
50LVSS15-6/4-65.5-e		914	402	327	84
50LVSS15-7/4-65.5-e		959	447	372	85
50LVSS15-8/4-65.5-e		1004	492	417	86
50LVSS15-10/4-65.5-e		1094	582	507	88
50LVSS15-12/4-65.5-e		1184	672	597	89
50LVSS15-14/4-65.5-e		1274	762	687	91
50LVSS15-17/4-65.5-e		1409	897	822	93
50LVSS15-5/5-67.5-e		904	357	282	90
50LVSS15-6/5-67.5-e		949	402	327	91
50LVSS15-7/5-67.5-e		994	447	372	92
50LVSS15-8/5-67.5-e		1039	492	417	93
50LVSS15-10/5-67.5-e		1129	582	507	94
50LVSS15-12/5-67.5-e		1219	672	597	96
50LVSS15-14/5-67.5-e		1309	762	687	98
50LVSS15-17/5-67.5-e		1444	897	822	100
50LVSS15-6/6-611-e		1117	402	327	111
50LVSS15-7/6-611-e	1162	447	372	112	
50LVSS15-8/6-611-e	1207	492	417	113	
50LVSS15-10/6-611-e	1297	582	507	115	
50LVSS15-12/6-611-e	1387	672	597	116	
50LVSS15-14/6-611-e	1477	762	687	118	
50LVSS15-17/6-611-e	1612	897	822	120	
50LVSS15-7/7-611-e	1162	447	372	112	
50LVSS15-8/7-611-e	1207	492	417	113	
50LVSS15-10/7-611-e	1297	582	507	115	
50LVSS15-12/7-611-e	1387	672	597	117	
50LVSS15-14/7-611-e	1477	762	687	118	
50LVSS15-17/7-611-e	1612	897	822	120	
50LVSS15-8/8-611-e	1207	492	417	113	
50LVSS15-10/8-611-e	1297	582	507	115	
50LVSS15-12/8-611-e	1387	672	597	117	
50LVSS15-14/8-611-e	1477	762	687	118	
50LVSS15-17/8-611-e	1612	897	822	120	
50LVSS15-10/10-615-e	1297	582	507	176	
50LVSS15-12/10-615-e	1387	672	597	177	
50LVSS15-14/10-615-e	1477	762	687	179	
50LVSS15-17/10-615-e	1612	897	822	181	
50LVSS15-12/12-618-e	1431	672	597	193	
50LVSS15-14/12-618-e	1521	762	687	194	
50LVSS15-17/12-618-e	1656	897	822	197	

●Discharge diameter: 50mm, Nominal flow rate: 20m<sup>3</sup>/h

50Hz

(Unit : mm)

Type	Fig.	L	LH	LK	Approx. mass(kg)
50LVSS20-3/1-51.1-e	2	676	267	192	33
50LVSS20-4/1-51.1-e		721	312	237	34
50LVSS20-5/1-51.1-e		766	357	282	35
50LVSS20-6/1-51.1-e		811	402	327	36
50LVSS20-3/2-52.2-e		676	267	192	41
50LVSS20-4/2-52.2-e		721	312	237	41
50LVSS20-5/2-52.2-e		766	357	282	42
50LVSS20-6/2-52.2-e		811	402	327	43
50LVSS20-7/2-52.2-e		856	447	372	44
50LVSS20-8/2-52.2-e		901	492	417	45
50LVSS20-10/2-52.2-e		991	582	507	46
50LVSS20-12/2-52.2-e		1081	672	597	48
50LVSS20-3/3-54.0-e		716	267	192	54
50LVSS20-4/3-54.0-e		761	312	237	55
50LVSS20-5/3-54.0-e		806	357	282	56
50LVSS20-6/3-54.0-e		851	402	327	57
50LVSS20-7/3-54.0-e		896	447	372	57
50LVSS20-8/3-54.0-e		941	492	417	58
50LVSS20-10/3-54.0-e		1031	582	507	60
50LVSS20-12/3-54.0-e		1121	672	597	62
50LVSS20-14/3-54.0-e	1211	762	687	63	
50LVSS20-17/3-54.0-e	1346	897	822	66	
50LVSS20-4/4-55.5-e	3	824	312	237	82
50LVSS20-5/4-55.5-e		869	357	282	83
50LVSS20-6/4-55.5-e		914	402	327	84
50LVSS20-7/4-55.5-e		959	447	372	85
50LVSS20-8/4-55.5-e		1004	492	417	86
50LVSS20-10/4-55.5-e		1094	582	507	88
50LVSS20-12/4-55.5-e		1184	672	597	89
50LVSS20-14/4-55.5-e		1274	762	687	91
50LVSS20-17/4-55.5-e		1409	897	822	93
50LVSS20-5/5-55.5-e		869	357	282	84
50LVSS20-6/5-55.5-e		914	402	327	84
50LVSS20-7/5-55.5-e		959	447	372	85
50LVSS20-8/5-55.5-e		1004	492	417	86
50LVSS20-10/5-55.5-e		1094	582	507	88
50LVSS20-12/5-55.5-e		1184	672	597	89
50LVSS20-14/5-55.5-e		1274	762	687	91
50LVSS20-17/5-55.5-e		1409	897	822	94
50LVSS20-6/6-57.5-e		949	402	327	91
50LVSS20-7/6-57.5-e		994	447	372	92
50LVSS20-8/6-57.5-e		1039	492	417	93
50LVSS20-10/6-57.5-e		1129	582	507	95
50LVSS20-12/6-57.5-e		1219	672	597	96
50LVSS20-14/6-57.5-e		1309	762	687	98
50LVSS20-17/6-57.5-e		1444	897	822	100
50LVSS20-7/7-57.5-e		994	447	372	92
50LVSS20-8/7-57.5-e		1039	492	417	93
50LVSS20-10/7-57.5-e		1129	582	507	95
50LVSS20-12/7-57.5-e		1219	672	597	96
50LVSS20-14/7-57.5-e		1309	762	687	98
50LVSS20-17/7-57.5-e		1444	897	822	101
50LVSS20-8/8-511-e	4	1207	492	417	174
50LVSS20-10/8-511-e		1297	582	507	175
50LVSS20-12/8-511-e		1387	672	597	177
50LVSS20-14/8-511-e		1477	762	687	179
50LVSS20-17/8-511-e		1612	897	822	181
50LVSS20-10/10-511-e		1297	582	507	175
50LVSS20-12/10-511-e		1387	672	597	177
50LVSS20-14/10-511-e		1477	762	687	179
50LVSS20-17/10-511-e		1612	897	822	181
50LVSS20-12/12-515-e		1387	672	597	177
50LVSS20-14/12-515-e		1477	762	687	179
50LVSS20-17/12-515-e		1612	897	822	182
50LVSS20-14/14-515-e		1477	762	687	179
50LVSS20-17/14-515-e		1612	897	822	182
50LVSS20-17/17-518-e		1656	897	822	198

60Hz

(Unit : mm)

Type	Fig.	L	LH	LK	Approx. mass(kg)	
50LVSS20-3/1-62.2-e	2	676	267	192	41	
50LVSS20-4/1-62.2-e		721	312	237	41	
50LVSS20-5/1-62.2-e		766	357	282	42	
50LVSS20-6/1-62.2-e		811	402	327	43	
50LVSS20-7/1-62.2-e		856	447	372	44	
50LVSS20-3/2-64.0-e		716	267	192	54	
50LVSS20-4/2-64.0-e		761	312	237	55	
50LVSS20-5/2-64.0-e		806	357	282	56	
50LVSS20-6/2-64.0-e		851	402	327	57	
50LVSS20-7/2-64.0-e		896	447	372	57	
50LVSS20-8/2-64.0-e		941	492	417	58	
50LVSS20-10/2-64.0-e		1031	582	507	60	
50LVSS20-12/2-64.0-e		1121	672	597	62	
50LVSS20-3/3-65.5-e		779	267	192	81	
50LVSS20-4/3-65.5-e		824	312	237	82	
50LVSS20-5/3-65.5-e		869	357	282	83	
50LVSS20-6/3-65.5-e		914	402	327	84	
50LVSS20-7/3-65.5-e		959	447	372	85	
50LVSS20-8/3-65.5-e		1004	492	417	86	
50LVSS20-10/3-65.5-e		1094	582	507	87	
50LVSS20-12/3-65.5-e	1184	672	597	89		
50LVSS20-14/3-65.5-e	1274	762	687	91		
50LVSS20-17/3-65.5-e	1409	897	822	93		
50LVSS20-4/4-67.5-e	3	859	312	237	89	
50LVSS20-5/4-67.5-e		904	357	282	90	
50LVSS20-6/4-67.5-e		949	402	327	91	
50LVSS20-7/4-67.5-e		994	447	372	92	
50LVSS20-8/4-67.5-e		1039	492	417	92	
50LVSS20-10/4-67.5-e		1129	582	507	94	
50LVSS20-12/4-67.5-e		1219	672	597	96	
50LVSS20-14/4-67.5-e		1309	762	687	97	
50LVSS20-17/4-67.5-e		1444	897	822	100	
50LVSS20-5/5-611-e		1072	357	282	170	
50LVSS20-6/5-611-e		1117	402	327	171	
50LVSS20-7/5-611-e		1162	447	372	172	
50LVSS20-8/5-611-e		1207	492	417	173	
50LVSS20-10/5-611-e		1297	582	507	175	
50LVSS20-12/5-611-e		1387	672	597	176	
50LVSS20-14/5-611-e		1477	762	687	178	
50LVSS20-17/5-611-e		1612	897	822	180	
50LVSS20-6/6-611-e		1117	402	327	171	
50LVSS20-7/6-611-e		1162	447	372	172	
50LVSS20-8/6-611-e		1207	492	417	173	
50LVSS20-10/6-611-e		1297	582	507	175	
50LVSS20-12/6-611-e		1387	672	597	176	
50LVSS20-14/6-611-e		1477	762	687	178	
50LVSS20-17/6-611-e		1612	897	822	181	
50LVSS20-7/7-615-e		4	1162	447	372	172
50LVSS20-8/7-615-e			1207	492	417	173
50LVSS20-10/7-615-e			1297	582	507	175
50LVSS20-12/7-615-e			1387	672	597	177
50LVSS20-14/7-615-e			1477	762	687	178
50LVSS20-17/7-615-e			1612	897	822	181
50LVSS20-8/8-615-e	1207		492	417	173	
50LVSS20-10/8-615-e	1297		582	507	175	
50LVSS20-12/8-615-e	1387		672	597	177	
50LVSS20-14/8-615-e	1477		762	687	178	
50LVSS20-17/8-615-e	1612		897	822	181	
50LVSS20-10/10-618-e	1341		582	507	191	
50LVSS20-12/10-618-e	1431		672	597	192	
50LVSS20-14/10-618-e	1521		762	687	194	
50LVSS20-17/10-618-e	1656		897	822	170	

### Detailed drawing of the terminal box

● Output 0.75 kW

#### Assembly drawing

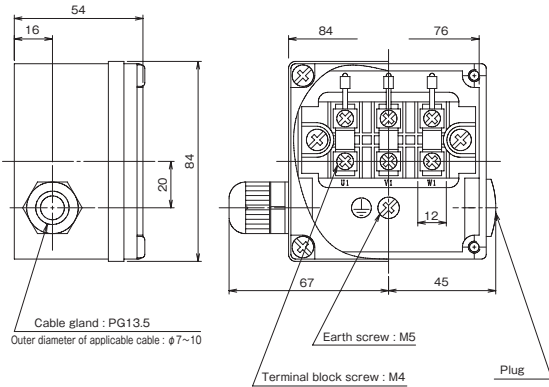

#### Connection diagram

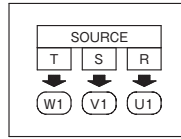

● Output 1.1 ~ 4.0 kW

#### Assembly drawing

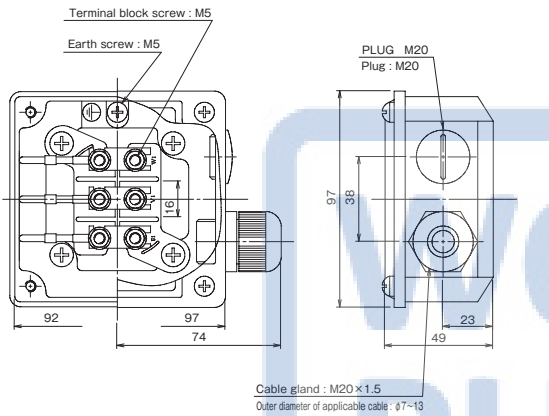

#### Connection diagram

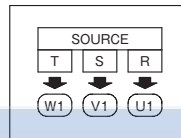

● Output 5.5, 7.5 kW

#### Assembly drawing

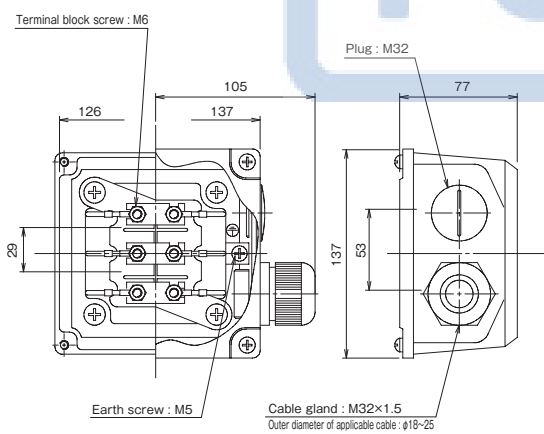

#### Connection diagram

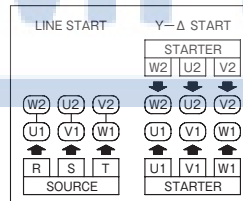

● Output 11 ~ 18.5 kW

#### Assembly drawing

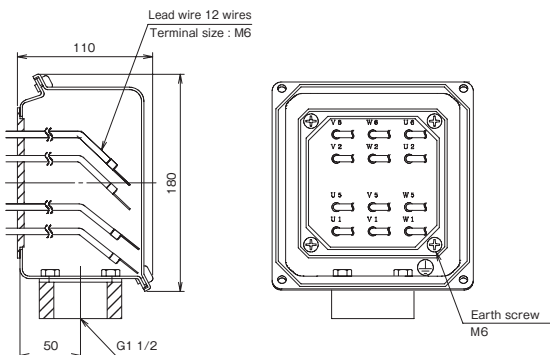

#### Connection diagram

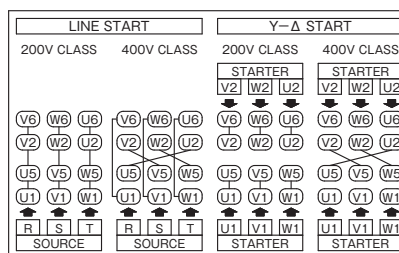

Sectional drawing

●32LVSS-e

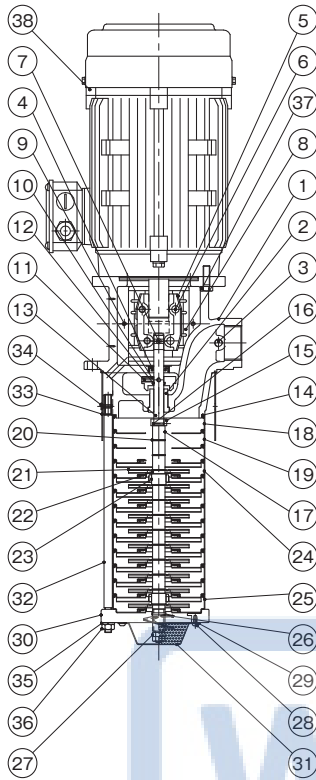

No.	Part name	Material
1	Discharge casing	SCS13
2	Bushing	SUS430
3	Plug	SUS304
4	Oil seal	NBR
5	Coupling	FC0205
6	Hexagon socket head bolt	SCM435
7	Shaft pin	SUS316
8	Coupling cover	SUS304
9	Cross-recessed pan head screw	SUS304
10	Oil thrower	SUS304
11	Set screw	SUS304
12	O-ring	FKM
13	Main shaft	SUS420J2
14	Gasket	—
15	Shaft bushing	SUS304
16	Shaft ring	SUS316
17	Sleeve	SUS304
18	Intermediate casing (Final stage)	SUS304
19	Intermediate casing	SUS304
20	Shim	SUS304
21	Impeller	SUS304
22	Baffle	SUS304
23	Bearings	SiC
24	Bearing casing	SUS304+SiC
25	Intermediate casing (First stage)	SUS304
26	Screw	SUS304
27	Hard locknut	SUS304
28	Cross-recessed pan head screw	SUS304
29	Protection plate	SUS304
30	Suction casing	SCS14A
31	Strainer	SUS304
32	Through bolt	SUS304
33	Outer sleeve	SUS304
34	Cross-recessed flat head screw	SUS304
35	Spring washer	SUS304
36	Hexagon nut	SUS304
37	Hexagon bolt	SUS304
38	Motor	—

Note 1) The materials in the table above are equivalents.  
Note 2) Structure and other details are subject to change without notice.

●50LVSS-e

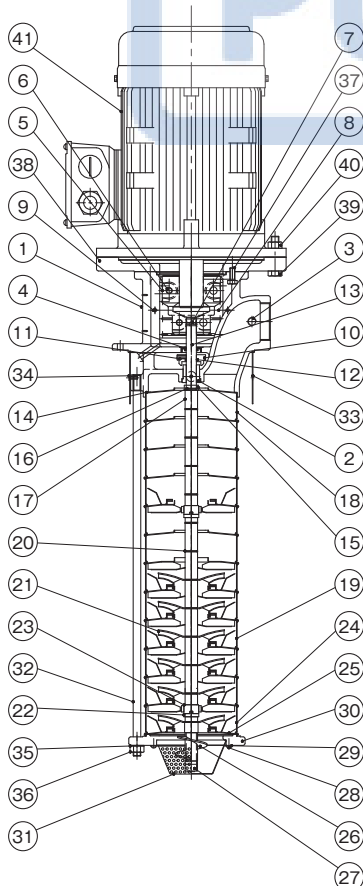

No.	Part name	Material
1	Discharge casing	SCS13
2	Air vent valve	SUS430
3	Plug	SUS304
4	Oil seal	NBR
5	Coupling	FC0205
6	Hexagon socket head bolt	SCM435
7	Shaft pin	SUS316
8	Coupling cover	SUS304
9	Cross-recessed pan head screw	SUS304
10	Oil thrower	SUS304
11	Set screw	SUS304
12	O-ring	FKM
13	Main shaft	SUS420J2
14	Gasket	—
15	Shaft bushing	SUS304
16	Shaft ring	SUS316
17	Sleeve	SUS304
18	Intermediate casing (Final stage)	SUS304
19	Intermediate casing	SUS304
20	Shim	SUS304
21	Impeller	SUS304
22	Baffle	SUS304
23	Bearings	SiC
24	Bearing casing	SUS304+SiC
25	Intermediate casing (First stage)	SUS304
26	Screw	SUS304
27	Hard locknut	SUS304
28	Cross-recessed pan head screw	SUS304
29	Protection plate	SUS304
30	Suction casing	SCS13
31	Strainer	SUS304
32	Through bolt	SUS304
33	Outer sleeve	SUS304
34	Cross-recessed flat head screw	SUS304
35	Plain washer	SUS304
36	Hexagon nut	SUS304
37	Hexagon bolt	SUS304
38	Frame spacer	FC200
39	Hexagon bolt	SUS304
40	Hexagon nut	SUS304
41	Motor	—

Note 1) The materials in the table above are equivalents.  
Note 2) Structure and other details are subject to change without notice.

Features

- ① The motor and the pump are integrated for smaller sizes and lighter weights.
- ② The self-priming function and floor mount offer a wider choice of installation locations, not limited to the top of tank.
- ③ EU RoHS Directive (RoHS 6 restricted substances) compliant.
- ④ EU Directive for CE marking compliant.
- ⑤ The lineup includes the models that meet efficiency of the various regulations:  
 VKN type : Equipped with a standard efficiency (IE1) motor.  
 VKN-e type : Equipped with a Top Runner efficiency (equivalent to IE3) motor (VKN115A).  
 VKN-7W type : Equipped with a UL approved motor.  
 (750W is NEMA premium efficiency.)
- ⑥ Enhanced protection against mist and other environmental elements is available.
- ⑦ The lineup that includes both VKN-A type (flow rate type) and VKN-H type (pressure type) broadens the scope of choices of heads and flow rates.  
 VKN-H type offers approximately 30% more pressure than VKN-A type.



Please note that the paint color, etc. of the actual unit may partially differ from the photo.

Description of types

**VKN 07 5 A**

①    ②    ③    ④    ⑤

- ① Model
- ② Output (04:40W, 05:60W, 06:100W, 07:180W, 08:250W, 09:400W, 11:750W)
- ③ Series number
- ④ Characteristics    L : flow rate type / cabtyre cable used  
 A : flow rate type  
 H : pressure type
- ⑤ Motor efficiency/voltage  
 None : Standard efficiency (equivalent to IE1) / Standard voltage  
 -e : Top Runner efficiency (equivalent to IE3) / Standard voltage  
 -4Z : Standard efficiency (equivalent to IE1) / Special voltage  
 -4Z-e : Top Runner efficiency (equivalent to IE3) / Special voltage  
 -7W : UL approved motor (750W is NEMA Premium efficiency)

Standard Specification

Used liquid	Property of liquid	Grinding liquid, cutting liquid, etc.*1
	Temperature	40°C or less (No frozen liquid)
	Allowable kinematic viscosity	VKN-A 50Hz : 200mm <sup>2</sup> /s 60Hz : 75mm <sup>2</sup> /s VKN-H 50/60Hz : 37.5mm <sup>2</sup> /s
Installation location		Indoor Ambient temperature: 0 to 40 °C, RH 85% or below (no condensation), Height above sea level : 1000m or less. Place not exposed to direct sunlight. Place in an area free of corrosive or explosive gas or vapor.
Material	Casing	FC150
	Impeller	CAC407 or Special resins Refer to the table of impeller materials.
	Main shaft	S45C
Shaft seal structure		Mechanical seal
Motor	Power source	3-phase 50/60/60 Hz, 200/200/220 V <sup>2</sup>
	Type	Totally enclosed fan-cooled indoor type
	Protection method	Refer to the specification table.
	Thermal class	Refer to the specification table.
	Rating	Continuous
	Number of poles	2P
Standard		IEC60034-1 CE marking*3
Paint color		Munsell N1

List of Consumable Parts

Type	Bearing		O-ring for casing
	Load side	Unload side	
VKN045L	6200ZZ	6200ZZ	—
VKN045A (-4Z/7W)	6200ZZ	6200ZZ	—
VKN055A (-4Z/7W)	6200ZZ	6200ZZ	—
VKN065A (-4Z/7W)	6200ZZ	6200ZZ	—
VKN075A (-4Z/7W)	6202ZZ	6200ZZ	—
VKN085A (-4Z/7W)	6202ZZ	6200ZZ	—
VKN095A (-4Z/7W)	6203ZZ	6202ZZ	—
VKN115A (-e/4Z/7W)	6305ZZ	6203ZZ	G165-N
VKN055H (-7W)	6200ZZ	6200ZZ	—
VKN065H (-7W)	6200ZZ	6200ZZ	—
VKN075H (-7W)	6202ZZ	6200ZZ	—
VKN085H (-7W)	6202ZZ	6200ZZ	—
VKN095H (-7W)	6203ZZ	6202ZZ	—

\*1 Take note that the unit is not used for water and special liquids such as printing and acidic liquids. Contact us when using the unit for other special liquids (ceramic, etc.).  
 \*2 -4Z type: 50/50/50/60/60Hz, 380/400/415/400/440V, -7W type: 60Hz, 208/230/460V  
 \*3 Excluding -7W type and the types whose ID ends with "L."

Selection chart

●VKN-A

(Values at kinematic viscosity  $1\text{mm}^2/\text{s}$ , specific gravity 1)  
(Values at kinematic viscosity  $75\text{mm}^2/\text{s}$ , specific gravity 1)

Synchronous rotating speed 50Hz :  $3000\text{min}^{-1}$   
60Hz :  $3600\text{min}^{-1}$

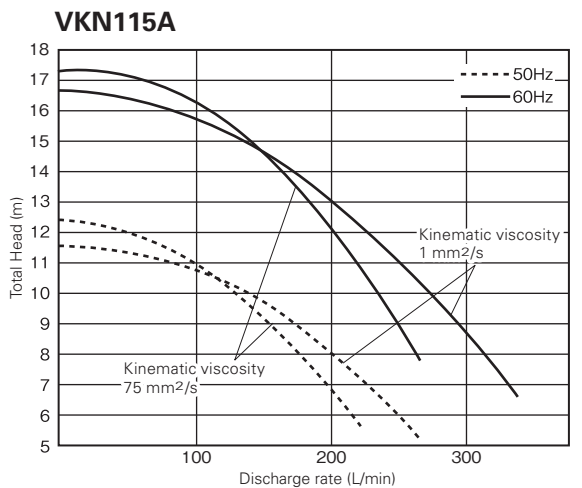
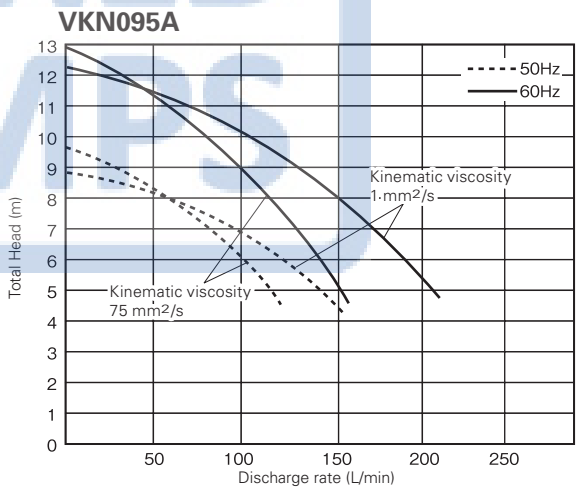
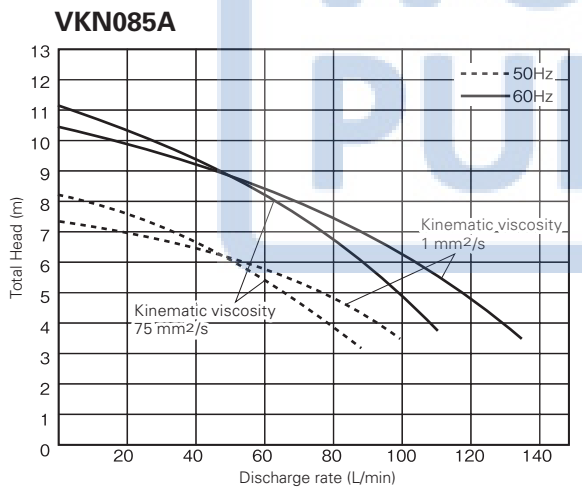
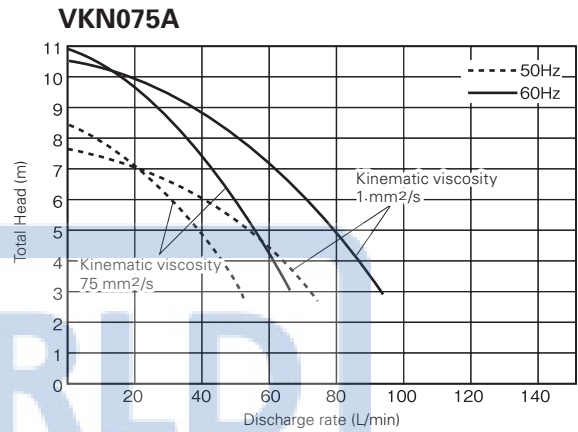
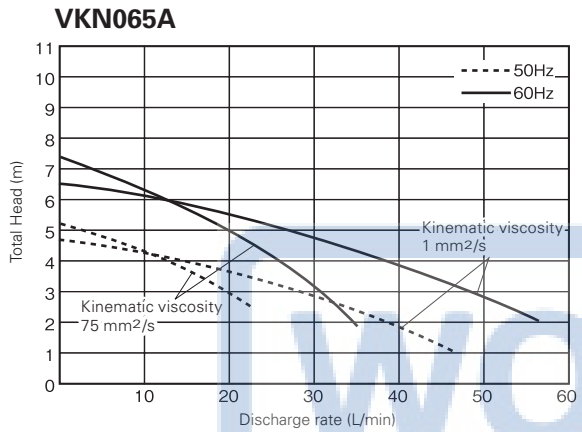
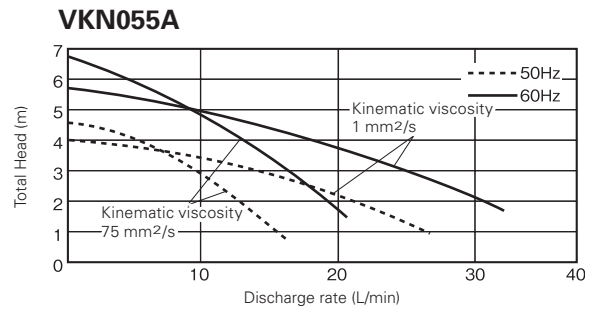
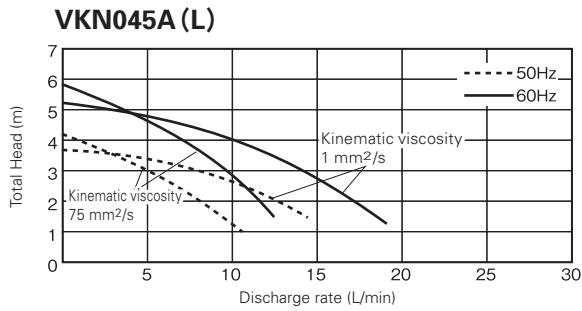

※ This also applies to -e/4Z/7W type.

Note) Take note that discharge rate varies considerably depending on the type and kinematic viscosity of liquid.

Selection chart

(Values at kinematic viscosity 1mm<sup>2</sup>/s, specific gravity 1)

Synchronous rotating speed 50Hz : 3000min<sup>-1</sup>  
60Hz : 3600min<sup>-1</sup>

●VKN-H

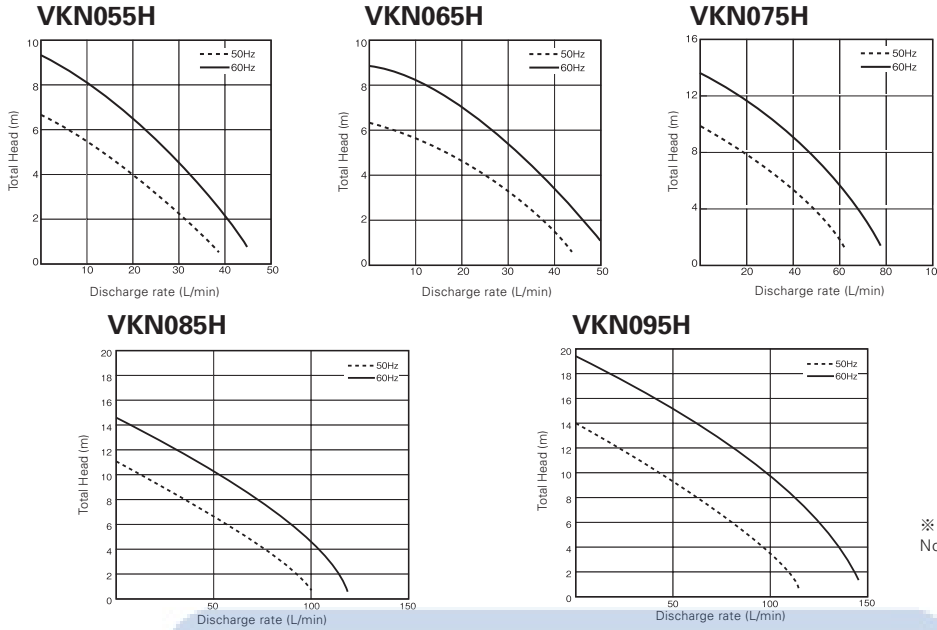

※ This also applies to -7W type.  
Note) Take note that discharge rate varies considerably depending on the type and kinematic viscosity of liquid.

Specification table

●VKN-A

Bore diameter (Rp)	Type	Output (W)	50Hz					60Hz					Protection method	Thermal class
			Rated voltage (V)	Rated current (A)	Discharge current (A)	Discharge rate (L/min)	Total Head (m)	Rated voltage (V)	Rated current (A)	Discharge current (A)	Discharge rate (L/min)	Total Head (m)		
1/4	VKN045L *	40	200	0.32	1.38	13	1.5	200/220	0.31/0.31	1.24/1.36	16	1.5	IP23	B
	VKN045A													
	VKN045A-4Z VKN045A-7W													
3/8	VKN055A	60	200	0.4	1.73	16	2	200/220	0.35/0.35	1.75/1.67	24	2	IP54	B
	VKN055A-4Z													
	VKN055A-7W													
	VKN065A	100	200	0.55	2.67	39	2	200/220	0.5/0.5	2.33/2.56	50	2		
	VKN065A-4Z													
VKN065A-7W														
1/2	VKN075A	180	200	0.85	5.86	50	3	200/220	1.0/1.0	5.52/6.08	67	3		
	VKN075A-4Z													
	VKN075A-7W													
3/4	VKN085A	250	200	1.2	8.79	95	4	200/220	1.5/1.5	8.26/9.09	130	4		
	VKN085A-4Z													
	VKN085A-7W													
1	VKN095A	400	200	2.4	11.0	140	5	200/220	2.5/2.4	10.0/11.0	200	5		
	VKN095A-4Z													
	VKN095A-7W													
1 1/2	VKN115A	750	200	3.3	25.7	230	7	200/220	4.5/4.2	23.3/25.7	320	7	IP54	B
	VKN115A-e													
	VKN115A-4Z													
	VKN115A-4Z-e													
	VKN115A-7W													

Notes 1) Since VKN045L has cabtyre cable, it does not conform to CE marking and its degree of protection is IP23.

Notes 2) The discharge rate and total head values were obtained in tests with a liquid kinematic viscosity of 1 mm<sup>2</sup>/s (same as fresh water at normal temperature). Take note that the pumps cannot be used with water.

●VKN-H

Bore diameter (Rp)	Type	Output (W)	50Hz					60Hz					Protection method	Thermal class
			Rated voltage (V)	Rated current (A)	Discharge current (A)	Discharge rate (L/min)	Total Head (m)	Rated voltage (V)	Rated current (A)	Discharge current (A)	Discharge rate (L/min)	Total Head (m)		
3/8	VKN055H	60	200	0.42	1.73	10	4.5	200/220	0.55/0.52	1.75/1.67	10	7	IP54	B
	VKN065H													
	VKN065H-7W													
1/2	VKN075H	180	200	0.9	8.79	20	7	200/220	1.2/1.1	8.26/9.09	11	11		
3/4	VKN085H	250	200	1.2	8.79	20	8	200/220	1.5/1.5	8.26/9.09	12	12		
1	VKN095H	400	200	2.4	11.0	20	12	200/220	2.5/2.4	10.0/11.0	20	17		
	VKN095H-7W													

Note) The discharge rate and total head values were obtained in tests with a liquid kinematic viscosity of 1 mm<sup>2</sup>/s (same as fresh water at normal temperature). Take note that the pumps cannot be used with water.

Assembly drawing

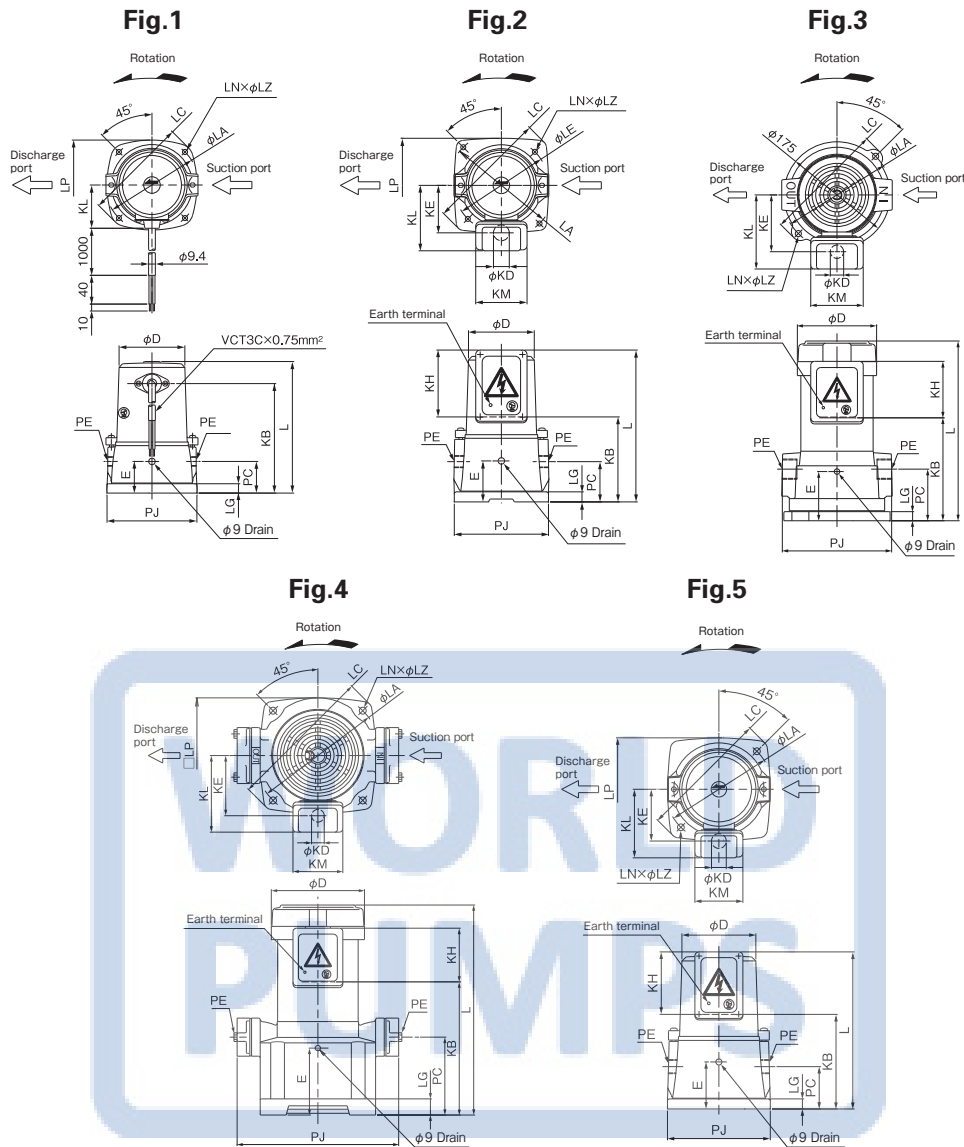

Dimensions

●VKN-A

(Unit : mm)

Type	Fig.	D	E	KB	KD	KE	KH	KL	KM	L	LA	LC	LE	LG	LN	LP	LZ	PC	PE	PJ	Approx. mass(kg)
VKN045L	1	92	44	151	—	—	—	61	—	183	130	145	—	13	4	125	7	44	Rp1/4	123	4.5
VKN045A(-4Z/7W)	2	92	44	96	22	67	93	93	73	189	130	145	—	13	4	125	7	44	Rp1/4	123	4.5
VKN055A(-4Z/7W)	2	92	57	119	22	67	93	93	73	212	130	169	132	14	4	131	7	56	Rp3/8	132	6.5
VKN065A(-4Z/7W)	2	92	57	119	22	67	93	93	73	212	150	169	132	14	4	131	7	56	Rp3/8	132	7.5
VKN075A(-4Z/7W)	2	111	61	143	22	78	93	104	73	236	164	194	160	15	4	153	10	63	Rp1/2	150	11.0
VKN085A(-4Z/7W)	2	122	73	157	22	81	93	107	73	250	170	194	160	15	4	153	10	71	Rp3/4	160	12.5
VKN095A(-4Z/7W)	3	131	81	169	22	94	93	122	87	296	180	200	—	15	2	—	10	85	Rp1	180	14.0
VKN115A(-4Z)	4	162	116	231	22	105	93	133	87	364	220	253	—	28	4	200	12	135	Rp1 1/2	280	23.0
VKN115A-e(-4Z/7W)	4	162	116	231	22	105	93	133	87	364	220	253	—	28	4	200	12	135	Rp1 1/2	280	24.0

●VKN-H

(Unit : mm)

Type	Fig.	D	E	KB	KD	KE	KH	KL	KM	L	LA	LC	LG	LN	LP	LZ	PC	PE	PJ	Approx. mass(kg)
VKN055H	5	92	57	119	22	67	93	93	73	212	132	169	14	2	131	7	56	Rp3/8	132	6.5
VKN065H(-7W)	5	92	57	119	22	67	93	93	73	212	132	169	14	2	131	7	56	Rp3/8	132	7.5
VKN075H	5	111	61	143	22	78	93	104	73	236	160	194	15	2	153	10	63	Rp1/2	150	11.0
VKN085H	5	122	73	157	22	81	93	107	73	250	160	194	15	2	153	10	71	Rp3/4	160	12.5
VKN095H(-7W)	3	131	81	169	22	94	93	122	87	296	180	200	15	2	—	10	85	Rp1	180	14.0



■ Detailed drawing of the terminal box

- VKN045 (L) ~85A (-4Z/7W),  
VKN055H~85H (-7W)

■ Assembly drawing

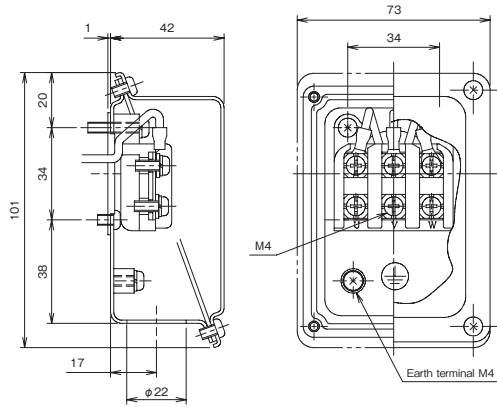

※ For the type whose ID ends with "L," cabtyre cable is used.

■ Connection diagram

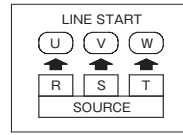

- VKN095 (-4Z), 115A (-e/4Z)

■ Assembly drawing

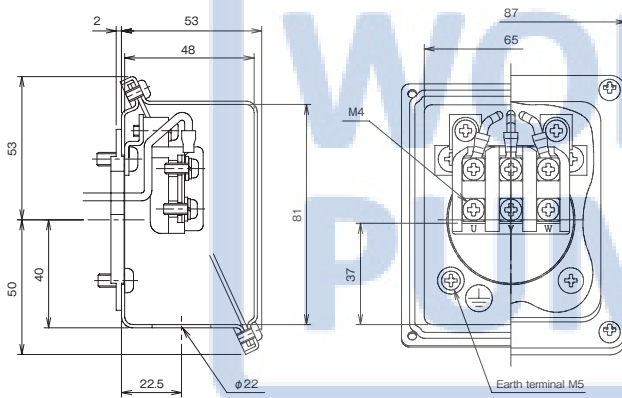

■ Connection diagram

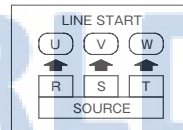

- VKN-7W

■ Assembly drawing

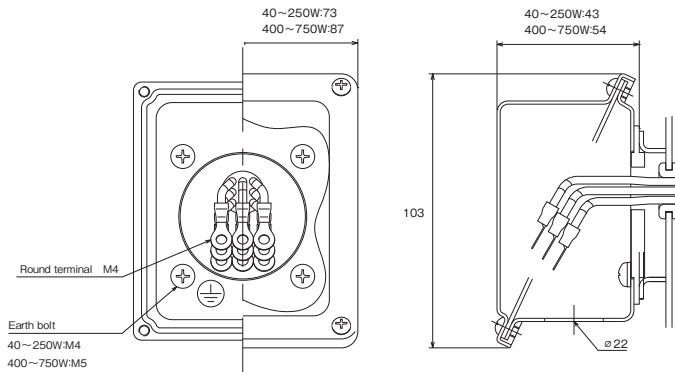

■ Connection diagram

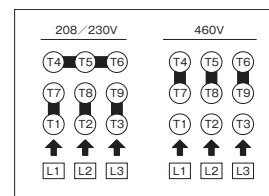

Sectional drawing

●VKN045L, VKN045A~85A (-4Z/7W),  
VKN055H~85H (-7W)

●VKN115A (-e/4Z/7W)

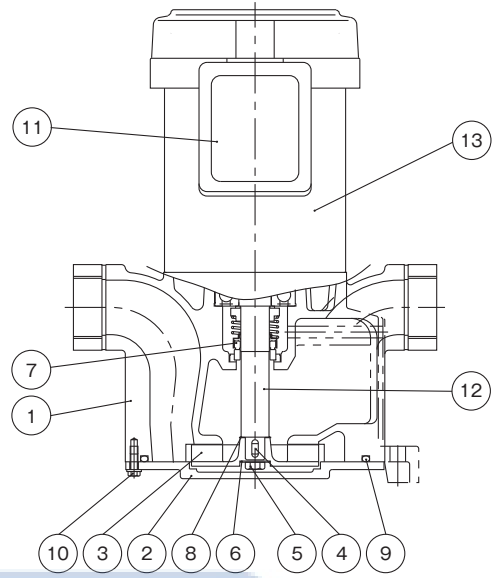
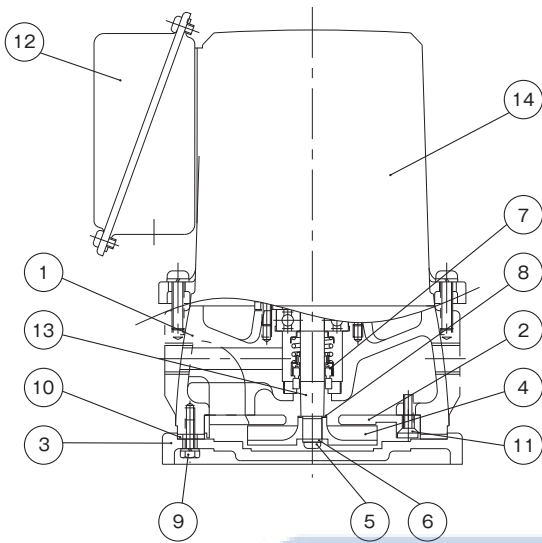

No.	Part name	Material	No.	Part name	Material
1	Casing	FC150	8	Adjust seal	BsP3-1/2H
2	Inner casing	FC150	9	Hexagon head screw with captive washer	SUS302
3	Bottom plate	FC150	10	Packing	NBR
4	Impeller	Refer to the table below	11	Flat head screw	SS
5	Pan head machine screw	SS	12	Terminal box	SPCC
6	Toothed washer	SK5	13	Main shaft	S45C
7	Mechanical seal	Ceramic vs carbon	14	Motor	-

No.	Part name	Material	No.	Part name	Material
1	Casing	FC150	8	Adjust seal	BsP3-1/2H
2	Bottom plate	FC150			Phosphor bronze
3	Impeller	CAC407	9	O ring	NBR
4	Key	S45C	10	Hexagon head screw with captive washer	SUS302
5	Hexagon bolt	SS	11	Terminal box	SPCC
6	Toothed washer	SK5	12	Main shaft	S45C
7	Mechanical seal	Ceramic vs carbon	13	Motor	-

Note 1) VKN045L has cabtyre cable.  
Note 2) The materials in the table above are equivalents.  
Note 3) Structure and other details are subject to change without notice.

Note 1) The materials in the table above are equivalents.  
Note 2) Structure and other details are subject to change without notice.

Table of impeller materials

●VKN-A

Type	Impeller materials
VKN045L	CAC407
VKN045A (-4Z/7W)	CAC407
VKN055A (-4Z/7W)	CAC407
VKN065A (-4Z/7W)	CAC407
VKN075A (-4Z/7W)	Special resins
VKN085A (-4Z/7W)	Special resins
VKN095A (-4Z/7W)	Special resins
VKN115A (-e/4Z/7W)	CAC407

●VKN-H

Type	Impeller materials
VKN055H	CAC407
VKN065H (-7W)	CAC407
VKN075H	CAC407
VKN085H	CAC407
VKN095H (-7W)	CAC407

Features

- ① Energy-saving pump equipped with a top-runner efficiency (equivalent to IE3) motor (LPS-e).
- ② The structure and materials are not easily affected by dirty coolants.
- ③ As impeller is made of FCD and non-seal (mechanical seal-less) structure is adopted, the pump is highly durable.
- ④ The self-priming function and floor mount offer a wider choice of installation location, not limited to the top of the tank.
- ⑤ Can be used for highly viscous coolants. (LPS40D-e)
- ⑥ The lineup includes the models that meet the efficiency of the various regulations:  
LPS-e type : Equipped with a Top Runner efficiency (equivalent to IE3) motor.  
(5.5 to 7.5kW is NEMA Premium motor)



Please note that the paint color, etc. of the actual unit may partially differ from the photo.

Description of types

**LPS 40 3 C - 3.0 T -e**

- ①
- ②
- ③
- ④
- ⑤
- ⑥
- ⑦

- ① Model
- ② Bore diameter
- ③ Number of impellers
- ④ Viscosity of the liquid  
A: for low viscosity liquid  
B: for high viscosity liquid
- ⑤ Output
- ⑥ ID code
- ⑦ Motor efficiency Top Runner efficiency (equivalent to IE3)

Standard Specification

Bore diameter		40mm	65mm
Used liquid	Property of liquid	Coolants of the kinematic viscosity equivalent to that of water-soluble coolants or water containing an additive (anticorrosive, etc.) <sup>*1</sup>	Water-soluble coolant liquid
	Temperature	0 to 60°C (No frozen liquid)	
	Allowable kinematic viscosity	40C: 32mm <sup>2</sup> /s 40D: 150mm <sup>2</sup> /s	1mm <sup>2</sup> /s
Installation location		Indoor Ambient temperature: 0 to 40 °C, RH 85% or below (no condensation), Height above sea level : 1000m or less, Place not exposed to direct sunlight, Place in an area free of corrosive or explosive gas or vapor.	
Max. intake piping length		0.7m <sup>*2</sup>	
Material	Casing (Suction・Discharge・Intermediate)	FC200	
	Impeller	FCD450	
	Shaft	S45C	
Shaft seal structure		Non-seal (mechanical seal-less)	
Motor	Power source	3-phase 50/60/60Hz 200/200/220V <sup>*3</sup>	
	Type	Totally enclosed fan-cooled indoor type	Totally enclosed fan-cooled outdoor type <sup>*4</sup>
	Protection method	IP44	IP55
	Thermal class	F	
	Rating	Continuous	
	Number of poles	2P	
Paint color		Munsell N1.5	

\*1 Avoid using the pump with water. Contact us when using the unit for coolant containing foreign substances with high hardness or a large amount of foreign substances including chips.  
\*2 Intake piping should be as short as possible and the number of bends and fittings as few as possible.  
\*3 LPW65-e: 3-phase 50/60/60Hz 200/200/230V  
\*4 The pump cannot be installed outdoors.

Special specification

Shaft seal structure is modified (to improve abrasion resistance).

Table of Consumable Parts

Output (kW)	Bearing		Oil seal	
	Load side	Unload side	Load side	Unload side
0.75	6306ZZC3	6203ZZC3	VC30508	—
1.5	6306ZZC3	6303ZZC3	VC30508	—
2.2	6306ZZC3	6303ZZC3	VC30508	—
3.0	6307ZZC3	6205ZZC3	VC30508	—
5.5	6309ZZC3	6306ZZC3	VC45628	VC30528
7.5	6309ZZC3	6306ZZC3	VC45628	VC30528

Bore diameter (mm)	O-ring (For discharge casing)	O-ring (For suction spacer)	O-ring (For interior surface of suction spacer)	O-ring (For bottom surface of suction spacer)	O-ring (For coolant sealing plate)
40	G155	G175	—	—	—
65	—	—	G270	G280	S56

Selection chart

●LPS40

●For low viscosity liquid (Values at kinematic viscosity  $1\text{mm}^2/\text{s}$ , specific gravity 1)

50Hz

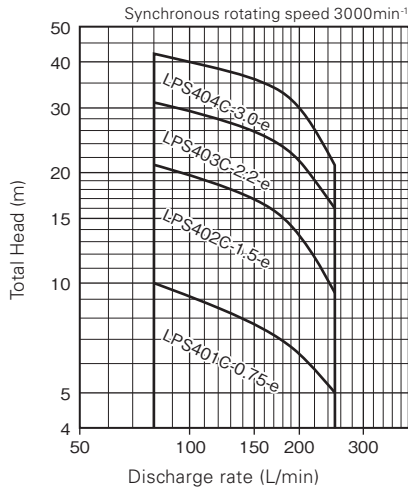

60Hz

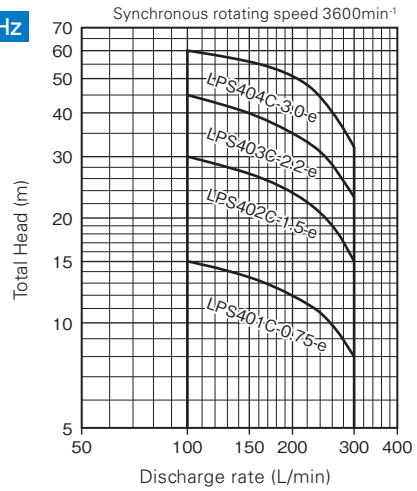

●For high-viscosity liquid (Value at kinematic viscosity  $150\text{mm}^2/\text{s}$ , specific gravity 1)

50Hz

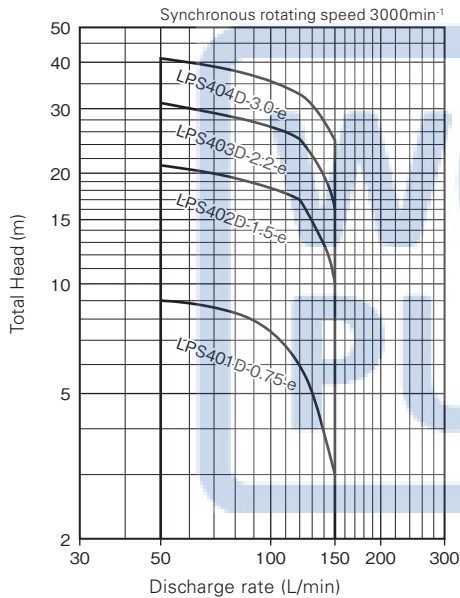

60Hz

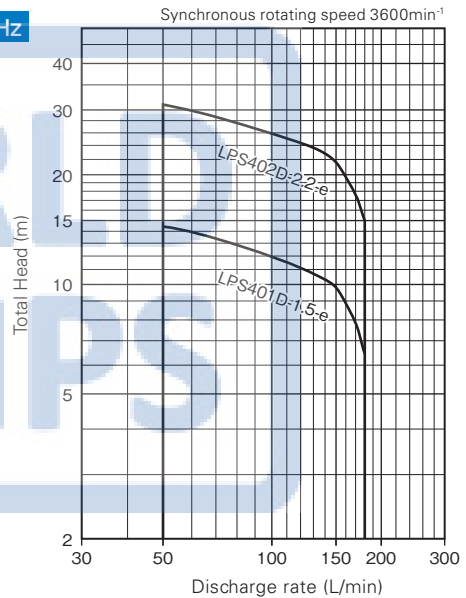

Specification table

●LPS40

Bore diameter (mm)	Used liquid	Frequency (Hz)	Type	Output (kW)	Rated voltage (V)	Rated current (A)	Starting current (A)	Discharge rate (L/min)	Total head (m)		
40	For low viscosity liquid	50	LPS401C-0.75T-e	0.75	200	3.5	30.0	80~250	10~5		
			LPS402C-1.5T-e	1.5		5.6	66.0		21~9.5		
			LPS403C-2.2T-e	2.2		8.0	84.0		31~16		
			LPS404C-3.0T-e	3.0		13.0	180		42~21		
			LPS401D-0.75T-e	0.75		4.0	30.0		9~3		
			LPS402D-1.5T-e	1.5		6.6	66.0		21~10		
	For high-viscosity liquid	50	LPS403D-2.2T-e	2.2	200	9.5	84.0	50~150	31~16		
			LPS404D-3.0T-e	3.0		14.8	180		41~25		
			LPS401C-0.75T-e	0.75		200/220	3.8/3.8		29.0/32.0	100~300	15~8
			LPS402C-1.5T-e	1.5			6.5/6.0		64.0/70.0		30~15
			LPS403C-2.2T-e	2.2			9.0/8.4		73.0/80.0		45~23
			LPS404C-3.0T-e	3.0			13.0/13.0		152/167		60~32
	LPS401D-1.5T-e	1.5	6.5/6.0	64.0/70.0	50~180		14~4				
	LPS402D-2.2T-e	2.2	9.0/8.4	73.0/80.0			31~13				

Note 1) The discharge rate and total head values were obtained in tests with a kinematic viscosity of 1 mm<sup>2</sup>/s (the same as starting current at normal temperature).  
Note 2) The pump's rated current (current value listed on the pump nameplate) is the recommended current setting for protection device.

Selection chart

●LPS65

●For low viscosity liquid (Values at kinematic viscosity 1mm<sup>2</sup>/s, specific gravity 1)

50Hz

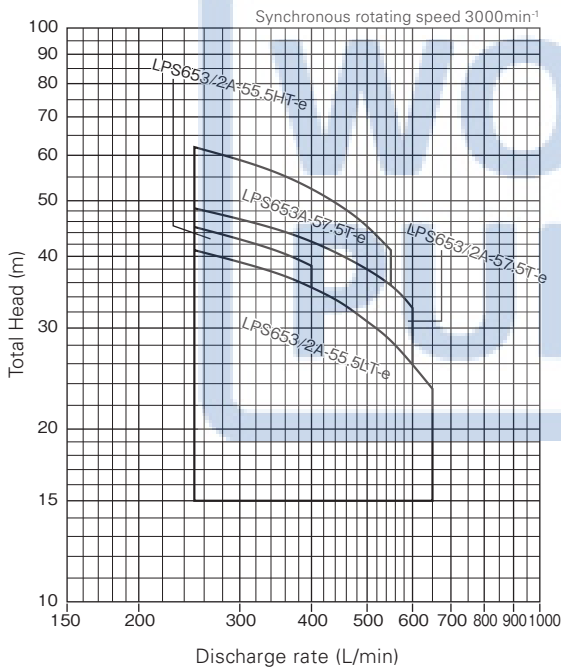

60Hz

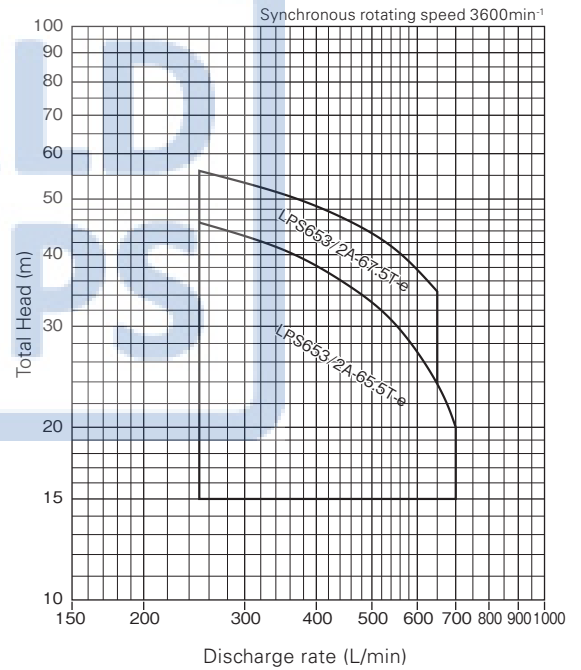

Specification table

●LPS65

Bore diameter (mm)	Frequency (Hz)	Type	Output (kW)	Rated voltage (V)	Rated current (A)	Starting current (A)	Discharge rate (L/min)	Total head (m)
65	50	LPS653/2A-55.5LT-e	5.5	200	20.3	204	250~650	41~23.5
		LPS653/2A-55.5HT-e	5.5		20.3	204	250~400	45~38.5
		LPS653/2A-57.5T-e	7.5		27.2	288	250~600	48.5~32.5
		LPS653A-57.5T-e	7.5		27.2	288	250~550	62~41
	60	LPS653/2A-65.5T-e	5.5	200/230	19.8/17.8	178/206	250~700	45.5~20
		LPS653/2A-67.5T-e	7.5		26.5/23.7	254/295	250~650	56~34.5

Assembly drawing

●LPS40

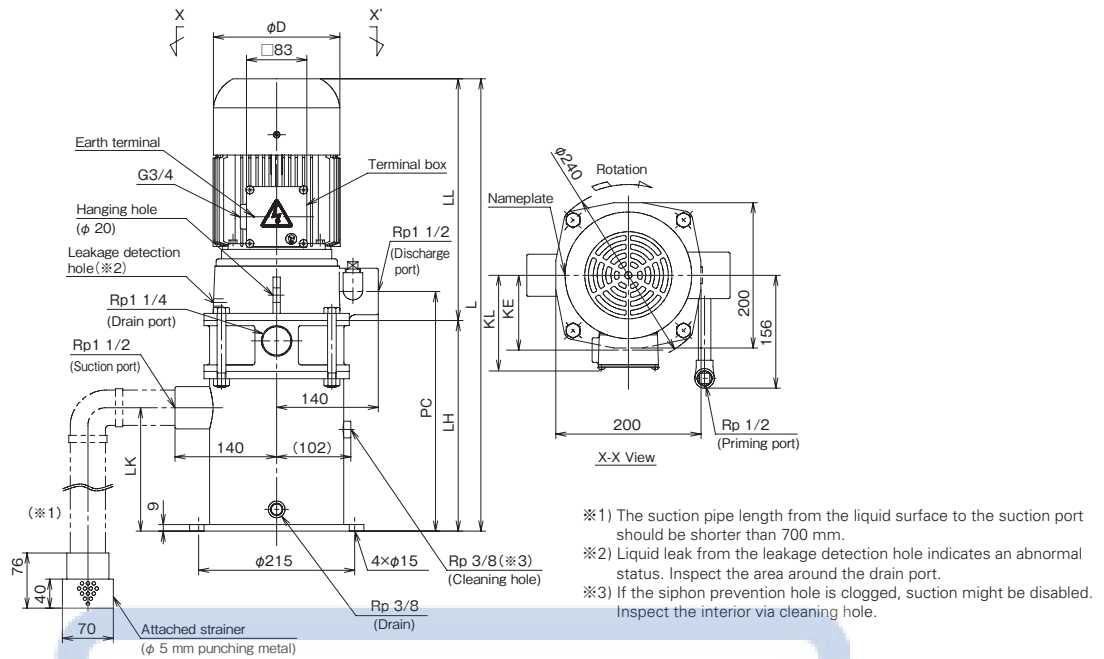

Dimensions

●LPS40

(Unit : mm)

Bore diameter (mm)	Used liquid	Frequency (Hz)	Type	D	KE	KL	L	LH	LK	LL	PC	Approx. mass(kg)
40	For low viscosity liquid	50/60	LPS401C-0.75T-e	140	88	112	578	290	170	288	330	37
			LPS402C-1.5T-e	175	103	130	623	290	170	333	330	43
			LPS403C-2.2T-e	175	103	130	623	290	170	333	330	51
			LPS404C-3.0T-e	195	113	140	699	335	215	364	375	58
	For high-viscosity liquid	50	LPS401C-0.75T-e	140	88	—	578	290	170	288	330	40
			LPS402D-1.5T-e	175	103	—	623	290	170	333	330	43
			LPS403D-2.2T-e	175	103	—	623	290	170	333	330	52
			LPS404D-3.0T-e	195	113	—	699	335	215	364	375	64
		60	LPS401D-0.75T-e	140	88	112	578	290	170	288	330	37
			LPS402D-1.5T-e	175	103	130	623	290	170	333	330	43
			LPS403D-2.2T-e	175	103	130	623	290	170	333	330	51
			LPS404D-3.0T-e	195	113	140	699	335	215	364	375	58
	60	LPS401D-1.5T-e	175	103	130	623	290	170	333	330	42	
		LPS402D-2.2T-e	175	103	130	623	290	170	333	330	50	

Assembly drawing

●LPS65

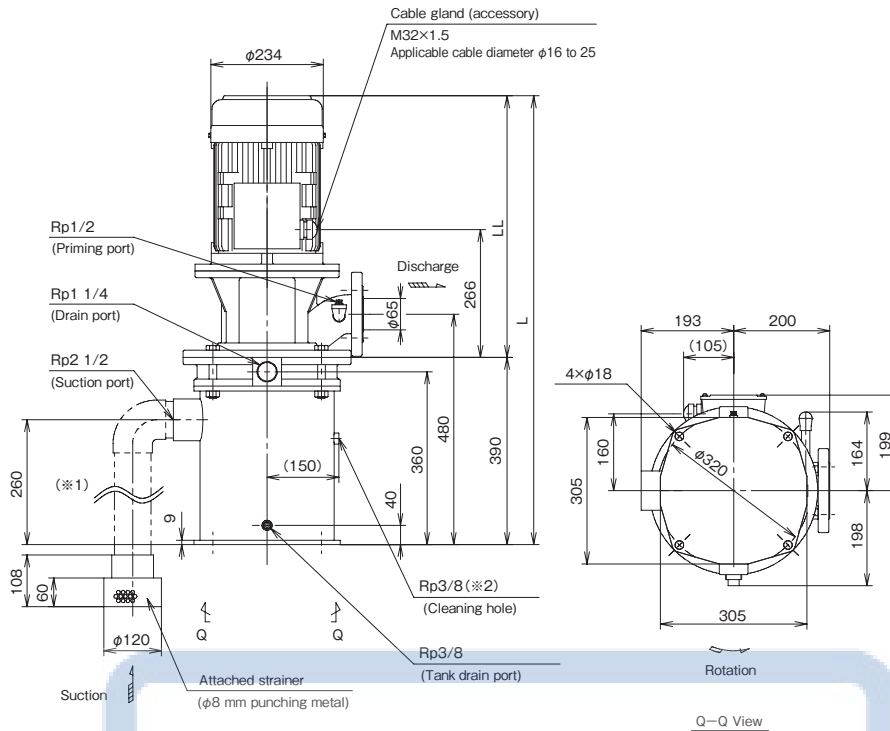

※1) The length of suction pipe from the liquid surface to the suction port should be shorter than 700 mm.  
 ※2) If the siphon prevention hole is clogged, suction might be disabled. Inspect the interior via cleaning hole.  
 A companion flange JIS 10K standard type is attached.

Dimensions

●LPS65

Bore diameter (mm)	Frequency (Hz)	Type	L	LL	Approx. mass(kg)
65	50	LPS653/2A-55.5LT-e	935	545	135
		LPS653/2A-55.5HT-e			135
		LPS653/2A-57.5T-e	970	580	141
		LPS653A-57.5T-e			143
60	60	LPS653/2A-65.5T-e	935	545	135
		LPS653/2A-67.5T-e			141

Detailed drawing of the terminal box

●LPS40-e

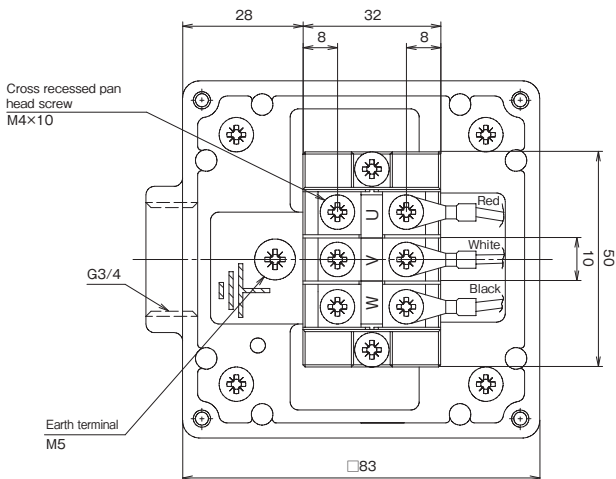

●LPS65-e

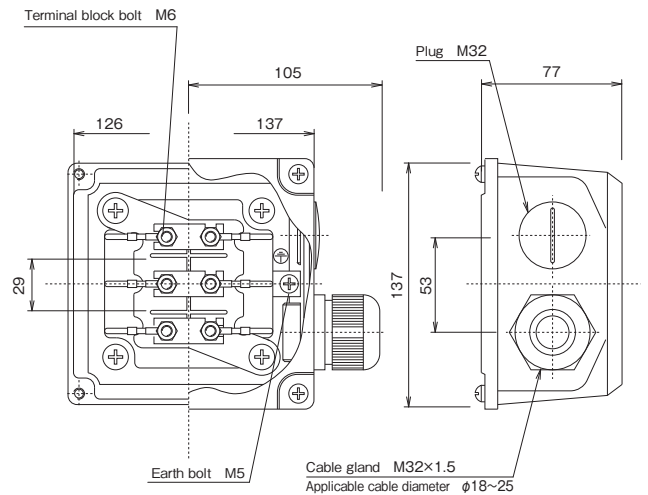

Sectional drawing

●LPS40

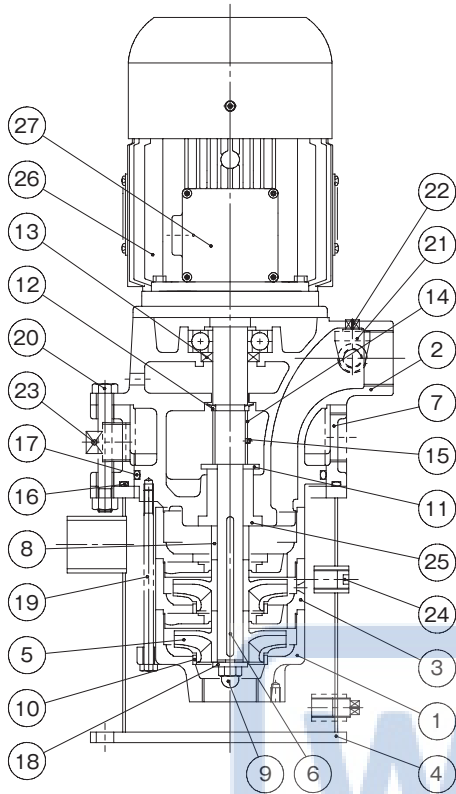

No.	Part name	Qty	Material
1	Suction casing	1	FC200
2	Discharge casing	1	FC200
3	Intermediate casing	2	FC200
4	Suction pipe	1	SS400
5	Impeller	2	FCD450
6	Main shaft	1	S45C
7	Suction spacer	1	FC200
8	Shaft spacer	1	STS
9	Impeller nut	1	SUS304
10	Liner ring	2	SUS304
11	Deflector	1	SS400
12	Deflector	1	NBR
13	Oil seal	1	NBR
14	Collar	1	STKM
15	Hexagon socket set screw	1	SCM435
16	O-ring	1	NBR
17	O-ring	1	NBR
18	Washer	1	SUS420J1
19	Through bolt	4	SS400
20	Through bolt	4	SS400
21	Elbow	1	FCMB
22	Plug	1	SS400
23	Plug	1	FCMB
24	Hexagonal socket sunk plug	1	SS400
25	Shaft sleeve	1	FCD450
26	Motor	1	
27	Terminal box	1	SECC

Note 1) The materials in the table above are equivalents.

Note 2) Structure and other details are subject to change without notice.

Applicable models : LPS402C-1.5T-e, LPS402D-1.5T-e, LPS402D-2.2T-e

●LPS65

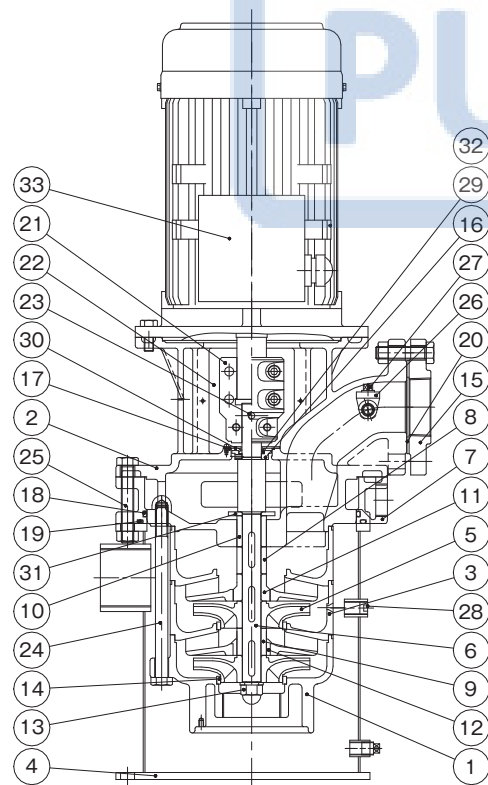

No.	Part name	Qty	Material
1	Suction casing	1	FC200
2	Discharge casing	1	FC200
3	Intermediate casing	2	FC200
4	Suction pipe	1	SS400
5	Impeller	2	FCD450
6	Main shaft	1	S45C
7	Suction spacer	1	FC200
8	Shaft sleeve A	2	SUS304
9	Shaft sleeve B	1	SiC
10	Shaft sleeve C	1	SUS304
11	Shaft sleeve D	1	SUS304
12	Intermediate bushing	1	SiC
13	Impeller nut	1	SUS304
14	Liner ring	2	SUS304
15	Companion flange	1	FC200
16	Deflector	1	C3604B
17	O-ring	1	NBR
18	O-ring	1	NBR
19	O-ring	1	NBR
20	Sheet packing	1	NBR
21	Coupling	1	FC200
22	Coupling cover	2	SUS304
23	Hexagon socket set screw	1	SCM435
24	Through bolt	4	SS400
25	Through bolt	4	SS400
26	Elbow	1	FCMB
27	Plug	1	SS400
28	Hexagonal socket sunk plug	1	SS400
29	V-ring	1	FKM
30	Coolant sealing plate	1	SUS304
31	Deflector	1	SUS304
32	Motor	1	
33	Terminal box	1	ADC12

Note 1) The materials in the table above are equivalents.

Note 2) Structure and other details are subject to change without notice.

Applicable models : 50Hz LPS653/2A-55.5LT-e, LPS653/2A-55.5HT-e,

LPS653/2A-57.5T-e

60Hz LPS653/2A-65.5T-e, LPS653/2A-67.5T-e



Features

- ① Bubbles and chips floating on the liquid surface can be suctioned continuously.
- ② Complete exhaust structure to prevent air lock (patented).
- ③ V-shaped inlet allowing suction even when fluid level fluctuates (patented).
- ④ The sliding mechanism that allows for manual adjustment of inlet to achieve the best suction conditions according to the liquid level during operation (patent pending).
- ⑤ Impeller allowing simultaneous suction from both above and below is adopted (patented).

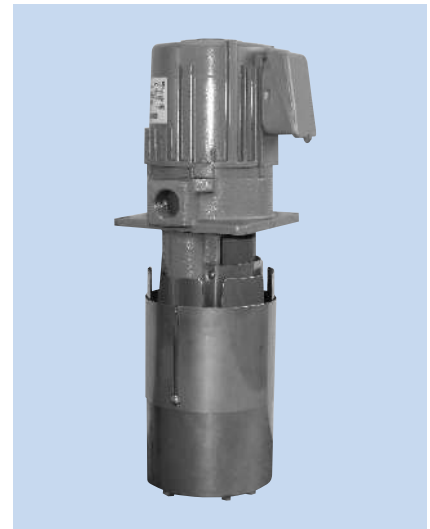
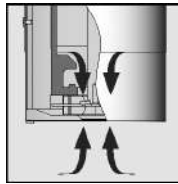
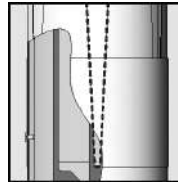

Please note that the paint color, etc. of the actual unit may partially differ from the photo.

The SKM Series resolves device failures caused by chips floating in the tank and the problems of fluid replacement and quality deterioration due to decayed sludge-like precipitate containing chips!

Effects generated from cleaning the coolant liquids:

- Improved processing accuracy
- Reduced manufacturing defects → Increased productivity → Cost reduction
- Reduced frequency of fluid replacement
  - Reduced frequency of disposal of oil waste → Environmental protection and cost reduction
  - Reduced amount of new oil to replace → Cost reduction
- Prevention of fluid decay → Improved work environment

Description of types

SKM-C 50 - L

①

②

③

- ① Model
- ② Discharge rate (L/min)
- ③ Head category L: low head  
H: high head

Selection chart

(Values at kinematic viscosity 1mm<sup>2</sup>/s, specific gravity 1)

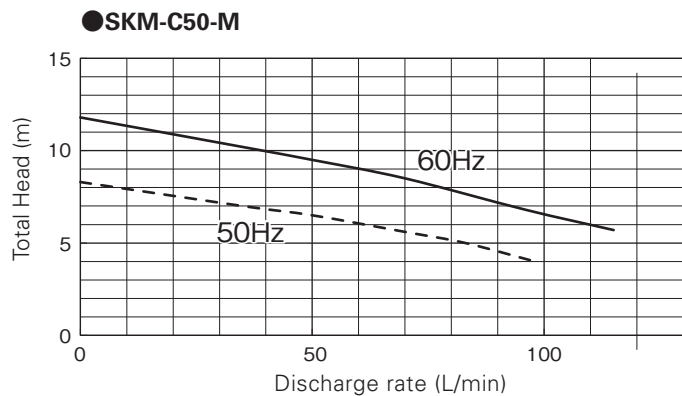
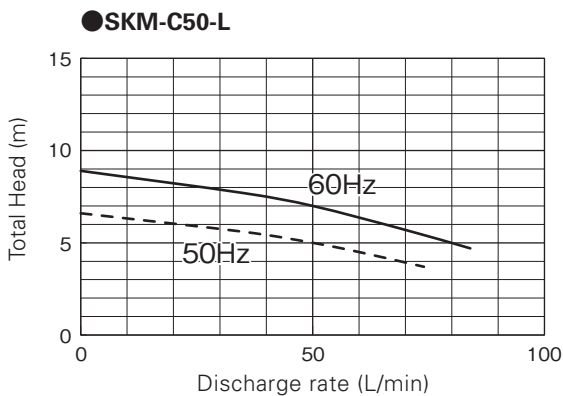

- Note 1) The performance of the pump represents the performance when used with the recommended liquid level.
- Note 2) The performance of the pump may change depending on the liquid level during operation.
- Note 3) If the liquid level during operation is high or discharge is low, suction of the surface water will decrease.

- Note 4) The pump should be installed in a place where the surface water is stable.
- Note 5) The pump should be used at a level higher than the lowest liquid level.
- Note 6) Suction is only carried out from the lower inlet if the liquid level is lower than the suction slit.

Specification table

Type		SKM-C50-L		SKM-C50-M	
Pump	Bore diameter	20mm			
	Discharge rate	50L/min	50L/min	50L/min	50L/min
	Total head	5m	7m	6.5m	9.5m
	Allowable kinematic viscosity	1mm <sup>2</sup> /s			
	Liquid filtration accuracy	Medium filtration accuracy (Max. chip size allowed within the pump: 4 mm)			
	Materials	Casing FC Impeller SUS304 Shaft S35C			
Motor	Phases	3-phase			
	Number of poles	2P			
	Output	0.18kW		0.25kW	
	Voltage	200V	200/220V	200V	200/220V
	Rated current	1.0A	1.1/1.0A	1.6A	1.7/1.6A
	Frequency	50Hz	60Hz	50Hz	60Hz
	Synchronous rotating speed	3000min <sup>-1</sup>	3600min <sup>-1</sup>	3000min <sup>-1</sup>	3600min <sup>-1</sup>
	Thermal class	B			
	Ambient temperature	0~40°C			
	Rating	Continuous			
	Protection method	Totally enclosed self-cooling indoor type		Totally enclosed fan-cooled indoor type	
	Bearing	Load side	6203ZZ		
Unload side		6201ZZAC			
Paint color	Munsell N5.5				

Assembly drawing

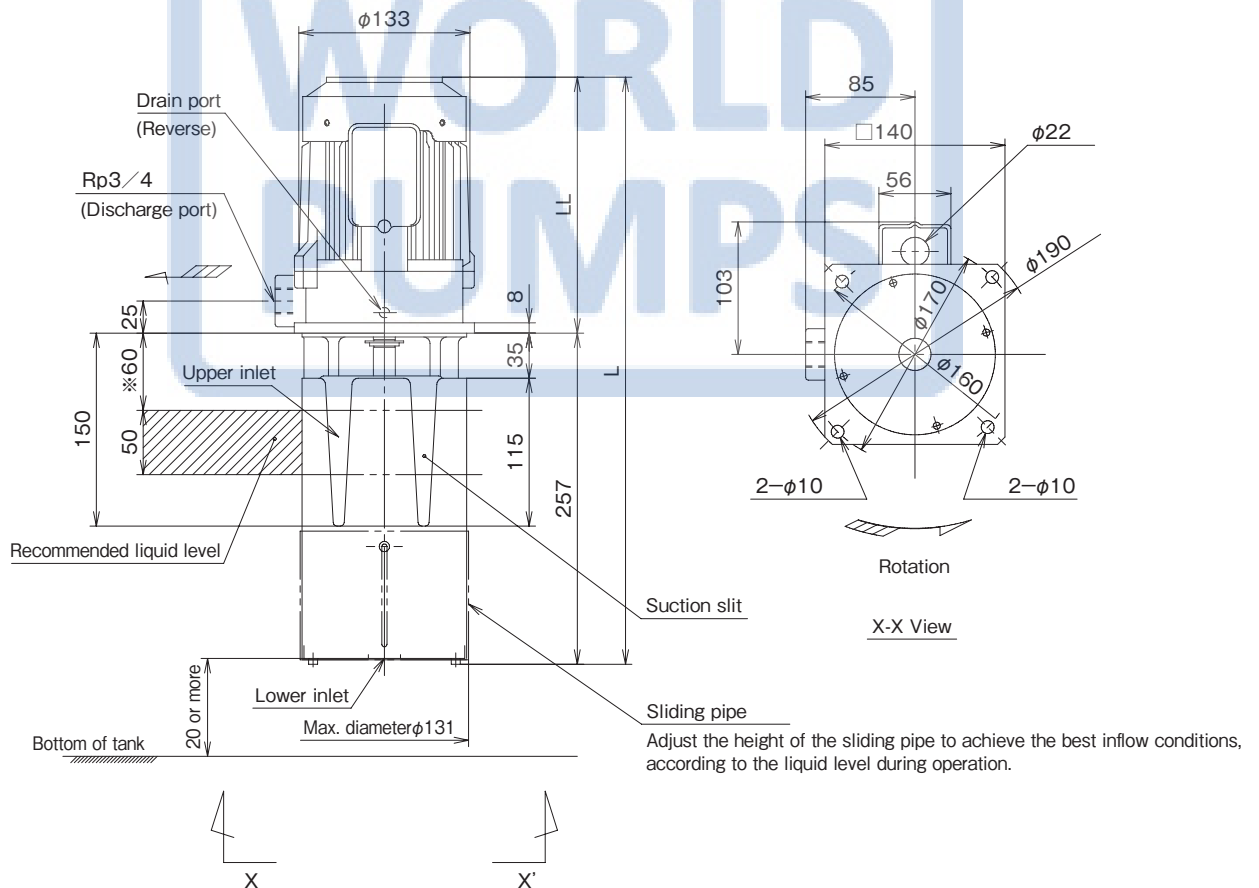

Dimensions

Type	L	LL	Approx. mass(kg)
SKM-C50-L	428	171	14.5
SKM-C50-M	456	199	15.0

※ When the liquid level during operation reaches 120mm or more below the base, the pump switches to the air suction operation.  
When the nominal discharge rate is exceeded, the pump also switches to the air suction operation.

