

NOP[®]

NOP[®] FILTER PUMP

NOP FILTER PUMP Product Guide



NOP[®]

Nippon Oil Pump Co., Ltd.

NOP FILTER PUMP COOLANT PUMP WITH BUILT-IN FILTRATION SYSTEM

High Pressure Model (3.0–7.0 MPa) High Pressure Unit for Through-spindle Coolant System

YTH-EP



Pump	Plunger	
Motor Capacity	2200–3700 W	
Flow Rate	12–28.8 L/min	
Maximum Pressure	7.0 MPa	
Filtration System	Turbulence™ filter	
Fluid Type	Water soluble coolant	Non-water soluble coolant
Compatibility	✓	Please consult us

Work Material	Steel	Cast metal	Al	Al-Si	Superalloy
Compatibility	✓	✓	✓	×	×

YTH-EP LINE TYPE



Pump	Plunger	
Motor Capacity	2200–3700 W	
Flow Rate	12–28.8 L/min	
Maximum Pressure	7.0 MPa	
Filtration System	Turbulence™ filter	
Fluid Type	Water soluble coolant	Non-water soluble coolant
Compatibility	✓	Please consult us

Work Material	Steel	Cast metal	Al	Al-Si	Superalloy
Compatibility	✓	✓	✓	×	×

Medium Pressure Model (1.5–2.0 MPa) Medium Pressure Unit for Through-spindle Coolant System

YTH-ES YTH-ES LINE TYPE



Pump	Trochoid™	
Motor Capacity	750–1500 W	
Flow Rate	12–28.8 L/min	
Maximum Pressure	2.0 MPa	
Filtration System	Turbulence™ filter	
Fluid Type	Water soluble coolant	Non-water soluble coolant
Compatibility	✓	✓ (Max. kinematic viscosity: 32 mm²/s)

Work Material	Steel	Cast metal	Al	Al-Si	Superalloy
Compatibility	✓	✓	✓	✓	✓

YTH-CT/CS YTH-CS LINE TYPE



Pump	Trochoid™	
Motor Capacity	750–1500 W	
Flow Rate	12–28.8 L/min	
Maximum Pressure	2.0 MPa	
Filtration System	Double-cyclone filter	
Fluid Type	Water soluble coolant	Non-water soluble coolant
Compatibility	✓ (Max. kinematic viscosity: 22 mm²/s)	×

Work Material	Steel	Cast metal	Al	Al-Si	Superalloy
Compatibility	✓	✓	✓	CT × CS ✓	CT × CS ✓

Low Pressure Model (35–65 m) Large Flow Low Pressure Unit

YTH-CI (Premium Model)



Pump	Impeller	
Motor Capacity	1500–3700 W	
Flow Rate	150–300 L/min	
Total Pump Head	40–65 m	
Filtration System	Reverse-cyclone filter	
Fluid Type	Water soluble coolant	Non-water soluble coolant
Compatibility	✓	✓ (Max. kinematic viscosity: 22 mm²/s)

Work Material	Steel	Cast metal	Al	Al-Si	Superalloy
Compatibility	✓	✓	✓	✓	✓

YTH-GCI (Standard Model)



Pump	Impeller	
Motor Capacity	1100–2200 W	
Flow Rate	70–300 L/min	
Total Pump Head	35–50 m	
Filtration System	Reverse-cyclone filter	
Fluid Type	Water soluble coolant	Non-water soluble coolant
Compatibility	✓	✓ (Max. kinematic viscosity: 22 mm²/s)

Work Material	Steel	Cast metal	Al	Al-Si	Superalloy
Compatibility	✓	✓	✓	✓	✓

Applications	
Machine tool equipped with through spindle coolant system (3.0 MPa up to 7.0 MPa) or jig cleaning nozzle (NC lathe, Machining center)	✓
Grinding machine	×
Electric discharge machine	×
Non-metal cutting machine (Resin, wood, glass)	×

Applications	
Machine tool equipped with through spindle coolant system (2.0 MPa or lower) or jig cleaning nozzle (NC lathe, Machining center)	✓
Grinding machine	×
Electric discharge machine	×
Non-metal cutting machine (Resin, wood, glass)	×

Applications	
Machine tools (NC lathe, Machining center)	✓
Grinding machine	✓
Electric discharge machine	×
Non-metal cutting machine (Resin, wood, glass)	▲

*Please contact us for further details about ▲.

CONTENTS

WHAT IS NOP FILTER PUMP?

FEATURES OF NOP FILTER PUMP	3
3 DIFFERENT TYPES OF FILTRATION SYSTEMS	5
PUMP SELECTION CHART	7
CALCULATION OF DISCHARGE PRESSURE AND FLOW	8

HIGH PRESSURE UNIT FOR THROUGH-SPINDLE COOLANT SYSTEM

YTH-EP Plunger Type High Pressure Unit (3.0–7.0 MPa)

MODEL NUMBERING SYSTEM	9
FEATURES OF YTH-EP	11
FEATURES OF YTH-EP LINE TYPE	13

MEDIUM PRESSURE UNIT FOR THROUGH-SPINDLE COOLANT SYSTEM

YTH-ES Trochoid™ Type Medium Pressure Unit (1.5–2.0 MPa)

MODEL NUMBERING SYSTEM	15
FEATURES OF YTH-ES	17
FEATURES OF YTH-ES LINE TYPE	20

YTH-CT/CS Trochoid™ Type Medium Pressure Unit (1.5–2.0 MPa)

MODEL NUMBERING SYSTEM	23
FEATURES OF YTH-CT/CS	25
PERIPHERAL OPTIONS (Inline Filter/Unloading Valve)	28
FEATURES OF YTH-CT/CS LINE TYPE	29

LARGE FLOW LOW PRESSURE UNIT

YTH-CI Large Flow Low Pressure Unit with Built-in Filtration System

(Head: 40–65 m)

MODEL NUMBERING SYSTEM	31
------------------------------	----

YTH-GCI Large Flow Low Pressure Unit with Built-in Filtration System

(Head: 35–50 m)

MODEL NUMBERING SYSTEM	33
FEATURES OF YTH-CI/GCI	35
SLUDGE COLLECTION WITH YTH-CI/GCI	36
APPLICATION EXAMPLES	37
YTH WIRE MESH BUCKET (Sludge Collection Bucket)	41

TAZUNA

TAZUNA

(Fluid Control System that Can Cut Maximum 61% Annual Electricity Cost) ... 42

SPECIFICATION TABLES FOR ALL NOP FILTER PUMP SERIES

SPECIFICATIONS FOR ALL YTH SERIES	45
TROUBLESHOOTING GUIDE	47
WORK MATERIAL COMPATIBILITY TABLES	48
QR CODE LIST	49
NOP FILTER PUMP INQUIRY FORM	50

*Please be sure to read the instruction manual before use.

FEATURES OF NOP FILTER PUMP—

Coolant Pump with Built-in Filtration System

YTH-EP (High Pressure)

YTH-ES/CT/CS (Medium Pressure) ————— Less Space Required

More Working Space

- You can create more working space by replacing your existing through spindle coolant unit with NOP filter pump.
- You can retrofit a through spindle coolant system to your existing machine simply by installing NOP filter pump.

Reduction in Filter Maintenance

- NOP filter pump can provide various solutions to your filter maintenance problems. For example, there is a filter on the pipeline to through spindle that needs to be cleaned quite frequently but you cannot afford to stop your production each time just because of this, or you may want to improve the logging condition in the through spindle pipeline.

Conventional Through Spindle Coolant System

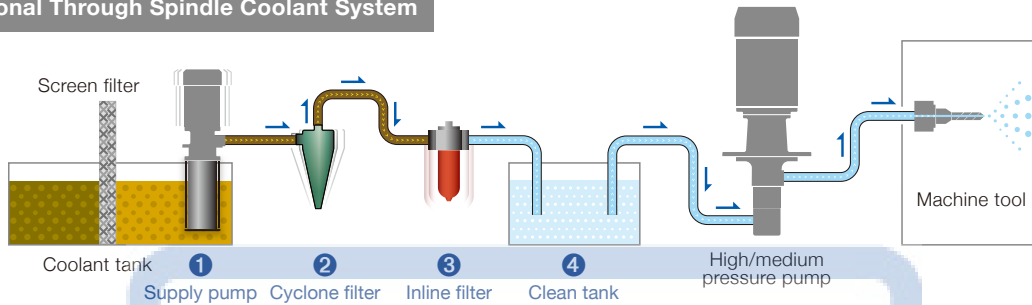

YTH-EP

YTH-ES

YTH-CT/CS

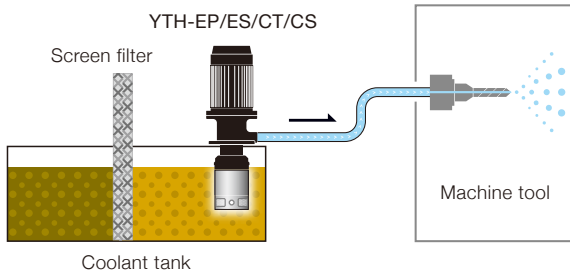

Various Components are All Combined in One

- ① No Supply Pump
- ② No Cyclone Filter
- ③ No Inline Filter
- ④ No Clean Tank

YTH-CI/GCI (Large Flow Low Pressure)

Excellent Performance in Sludge Removal in a Coolant Tank

Solution to the Various Problems Around the Coolant Tank

- Cyclone system with large filtration capacity ensures the excellent performance in coolant tank cleaning.
- Substantial reduction in maintenance work due to clogged pipe, damaged work-pieces and frequent machine downtime.
- Easy retrofitting to your existing machine. The sludge problem occurs after you start using a new machine.

Conventional Coolant System

[Pump discharges coolant that contains sludge]

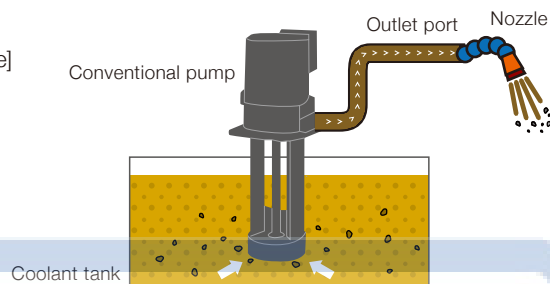

YTH-CI



YTH-GCI



[Pump only discharges filtered clean coolant]

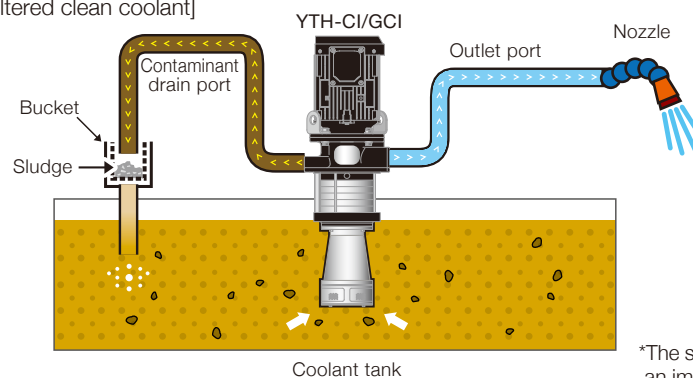

*The sludge in the tank above is just an image for illustration purposes.

3 DIFFERENT TYPES OF FILTRATION SYSTEMS

1 NOP's Self-developed Filtration System "Turbulence™ Filter"

YTH-EP/YTH-ES

Our special Turbulence™ design generates turbulence around the surface of filter with 2 wing-shaped vanes rotating around filter and can wash away sludge from the filter surface continuously.

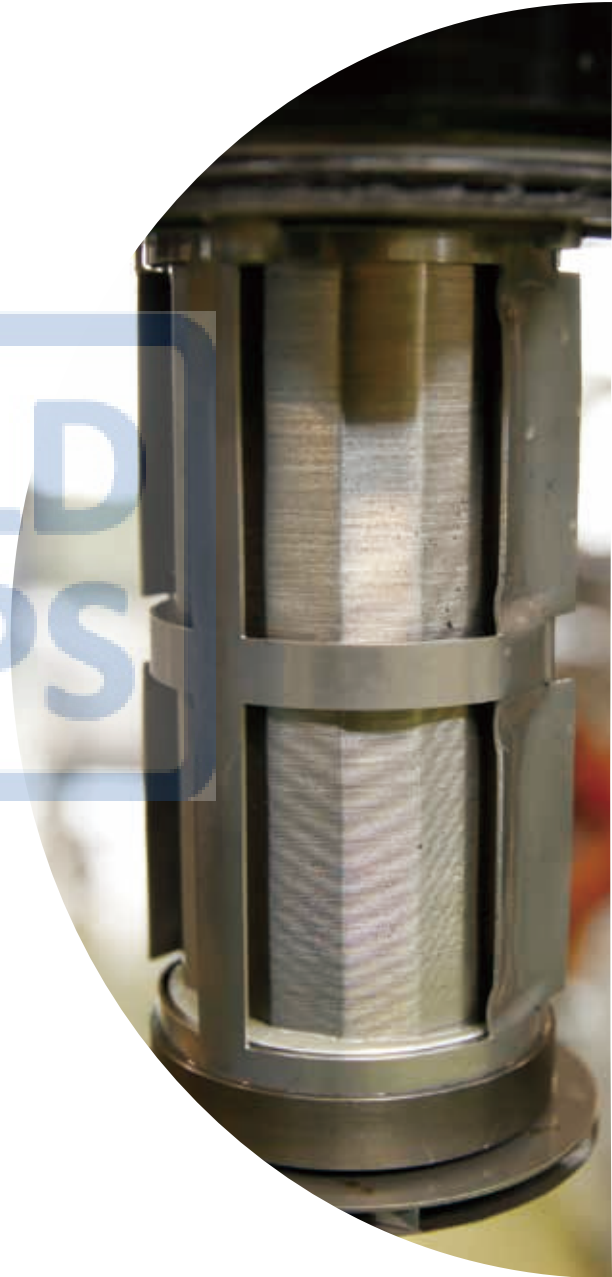
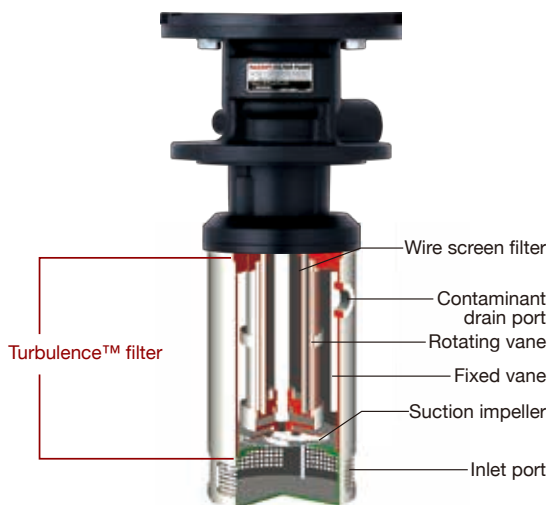
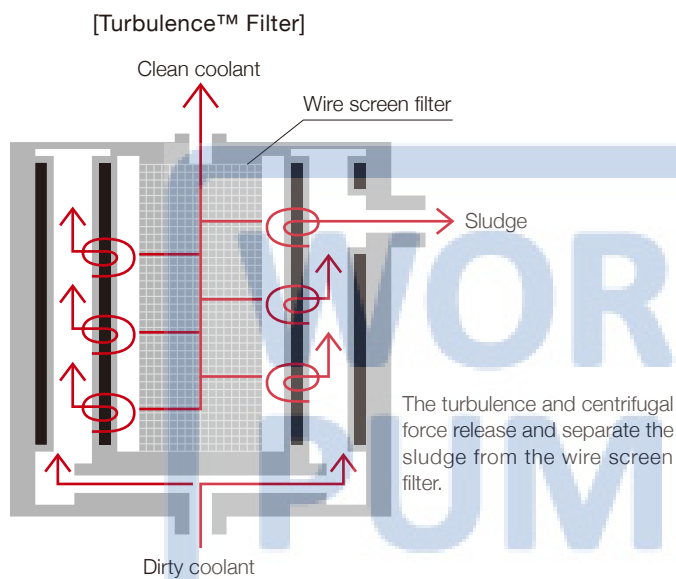

2 Combination of 1st Large and 2nd Small Cyclones, "Double-cyclone Filter"

YTH-CT/CS

A proprietary double cyclone system removes sludge.

The first large cyclone removes larger debris, while the second 6 small cyclones remove smaller particles, achieving compactness and high filtration performance simultaneously.

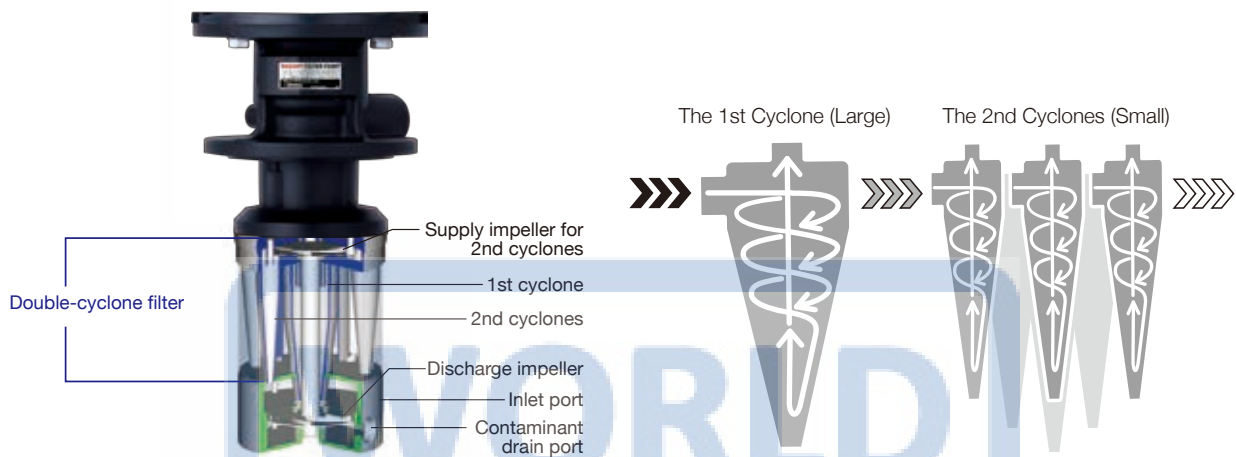

3 Reversed-cyclone Filter

YTH-CI/GCI

The compactness of reversed-cyclone design ensures excellent filtration performance and allows installation on the top of coolant tank.

Cone-shaped cyclone unit draws coolant from the tank and filters it and separates into dirty and clean coolant.

Both will be discharged separately from the pump upper area.

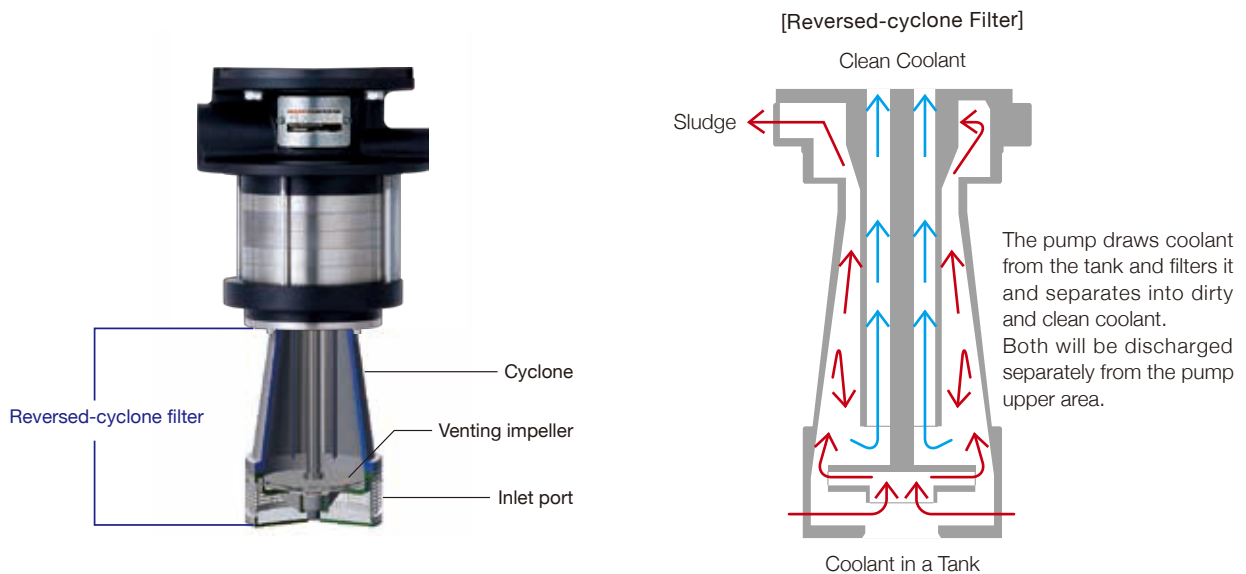

PUMP SELECTION CHART — Select a Pump by Application

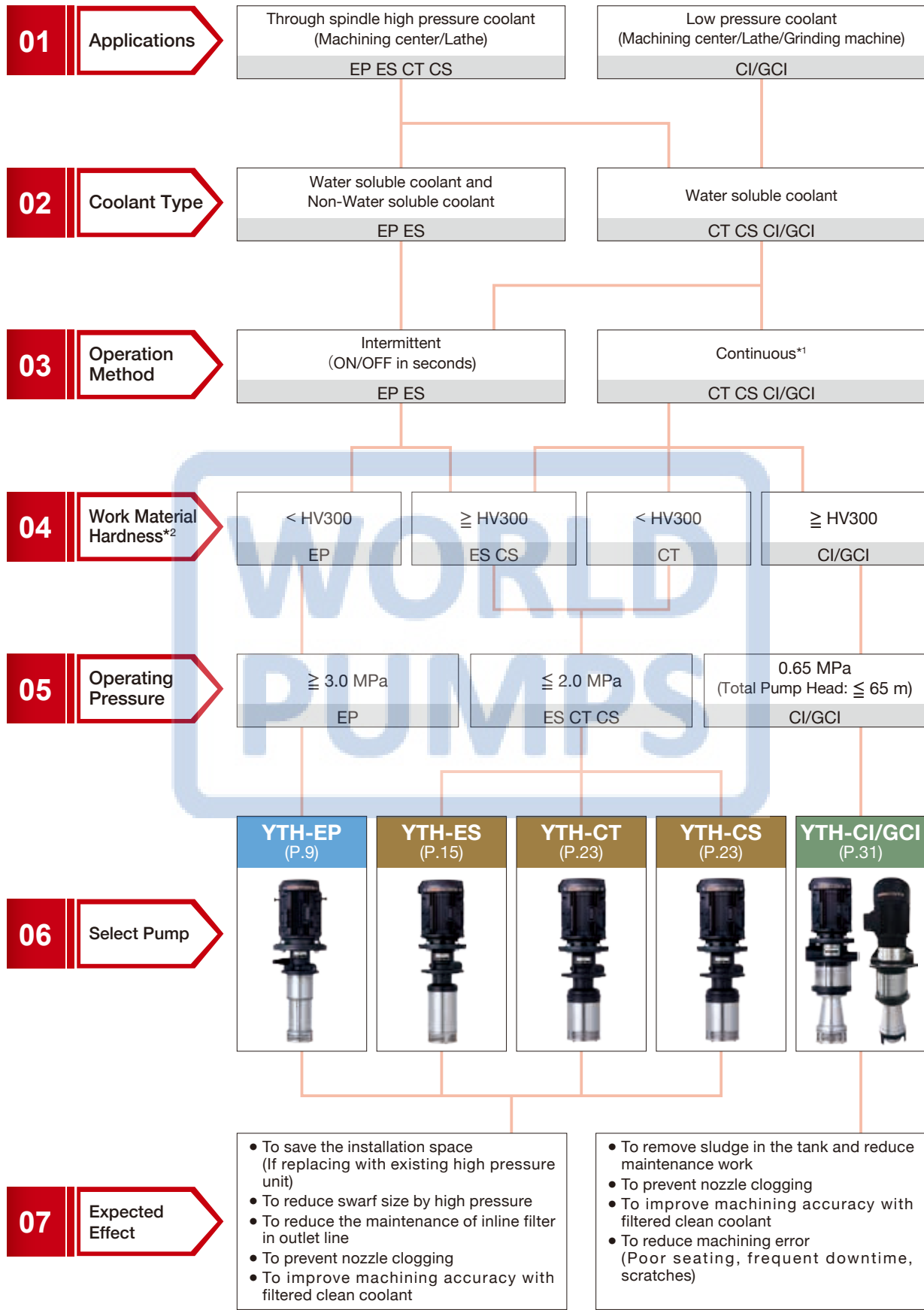

*1 Intermittent operation is also possible if an unloading valve is installed.

*2 Work material hardness given in this chart is a guide only. The actual hardness varies depending on components and constituent elements contained in work materials regardless of HV300. See P.48 "WORK MATERIAL COMPATIBILITY TABLES."

CALCULATION OF DISCHARGE PRESSURE AND FLOW

Pump Performance Chart by Tool Holes

This chart is to help you understand discharge performance of your pump by calculating the outlet flow rate based on the number of through spindle holes and the diameter of any one of those holes.

The outlet flow rate can be determined by the tool holes (The number of holes and hole diameter) and the outlet pressure.

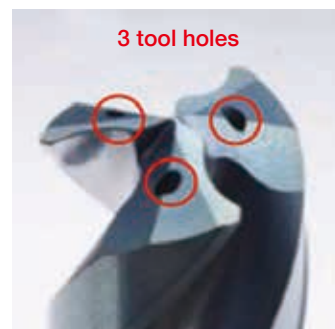

Example

When your through spindle has 2 holes of $\Phi 1.8$ and the outlet pressure is at 2.0 MPa, the flow rate should be approximately 12.0 L/min. (The pump can only discharge 12.0 L/min at 2.0 MPa, although the pump's theoretical maximum flow rate is 28.8 L/min.)

[How to Use This Chart]

1. First, select a chart page that matches your model of NOP filter pump and the number of holes on your tool.
2. Select a colored area that matches the model number of your NOP filter pump and rotational speed (frequency of your area and TAZUNA).
*If TAZUNA is installed, the maximum rotational speed should be 2000 min⁻¹.
3. Select a curve that matches a hole diameter of your through spindle.

Finally, you can get the outlet pressure and flow rate by checking a point where curve (hole diameter) and colored area intersect.

*The data of this chart was obtained only under the following conditions and therefore, provided for reference only.

The actual performance is subject to the viscosity of pumped liquid and piping resistance.

Test oil: Water soluble coolant emulsion A1 type 2% Liquid temperature: 20°C.

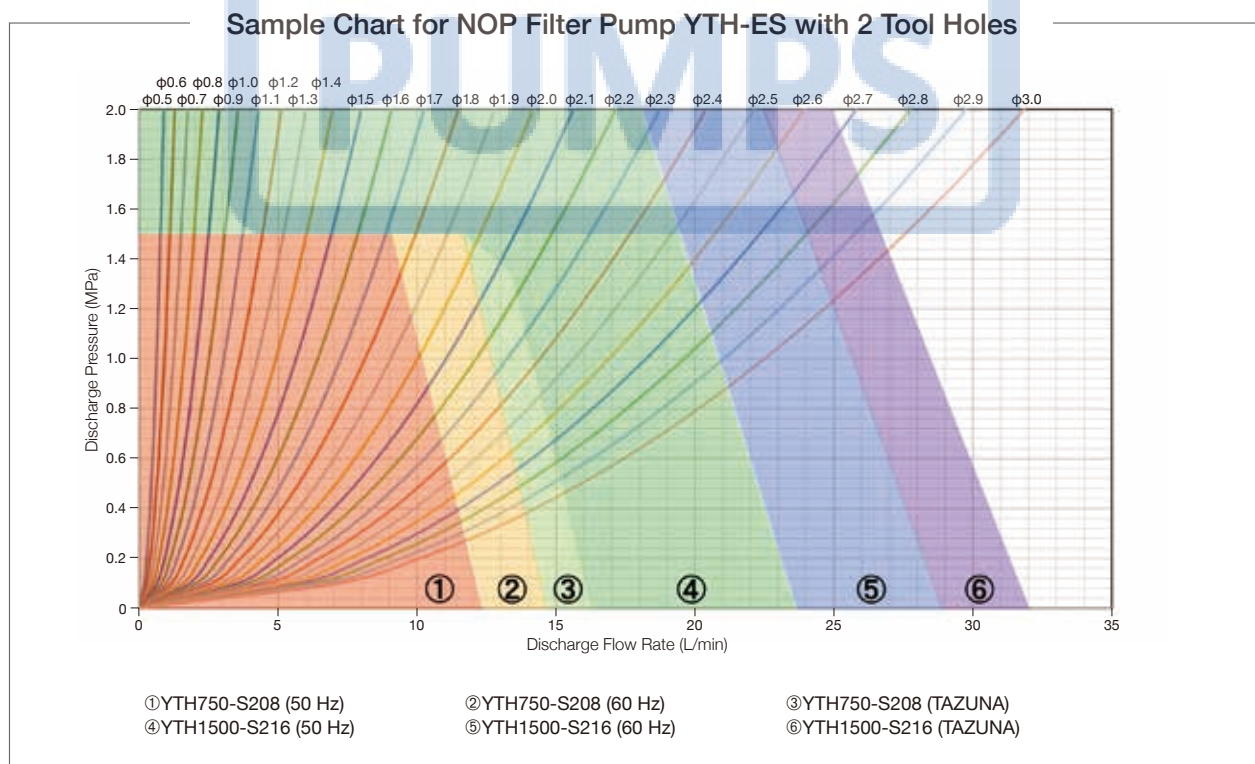

For the Other Number of Tool Holes and Pump Models



Scan with
your mobile device !

YTH-EP

Received the "2015 JSME Excellent Product Award"

Plunger Type 7.0 MPa High Pressure Unit

Turbulence™ Filter

Special turbulence cleans the filter automatically, rendering the filter clog free.

Plunger Pump/7.0 MPa–3.0 MPa

Piston action pushes fluid at high to medium pressure.

Compatible with TAZUNA™ Fluid Control System (Software)

TAZUNA reduces the electric power cost further by approximately 20%.
The pressure and flow rate are automatically adjusted.



MODEL NUMBERING SYSTEM

TOP—YTH ① ② - ③ E VD ④ ⑤

①Motor Capacity	②Motor Type*1	③Pump Capacity (Plunger pump)	E: Filtering Method	VD: Relief Valve	④Relief Pressure Setting*2	⑤Filter Rating
2200: 2.2 kW 3700: 3.7 kW	[Standard Motor] A3: AC 200/200/220/230 V 50/60/60/60 Hz 3 phase electric induction motor (IE3) with CE marking	P008: 8 cc/rev P010: 10 cc/rev P014: 14 cc/rev P016: 16 cc/rev	Turbulence™ filter	External return type	70: 7.0 MPa 60: 6.0 MPa 35: 3.5 MPa 30: 3.0 MPa	B: 50 μm*3 C: 20 μm*4
	[Local Motor] AE: supplied by NOP Germany AF: supplied by NOP Taiwan AJ: supplied by NOP Asia (China) AK: supplied by NOP India AU/AV: supplied by NOP North America (USA)					

*1 For further details about the local motors, please contact our overseas branch or subsidiaries.

*2 See P.45 to select a model that satisfies your desired relief valve set pressure.

*3 Please consult us if you use non-water soluble coolant as they can only be used in limited conditions.

*4 20 μm filter can not be applied to non-water soluble coolant.

SPECIFICATIONS

Model	Motor Capacity (kW)	Flow Rate (L/min) 50 Hz/60 Hz	Maximum Pressure (MPa) 50 Hz/60 Hz	Approximate Weight (kg)
YTH2200A3-P008EVD70*	2.2	12.0/14.4	7.0/7.0	53
YTH2200A3-P010EVD**	2.2	15.0/18.0	7.0/6.0	53
YTH2200A3-P016EVD**	2.2	24.0/28.8	3.5/3.0	53
YTH3700A3-P014EVD70*	3.7	21.0/25.2	7.0/7.0	62
YTH3700A3-P016EVD**	3.7	24.0/28.8	7.0/6.0	62

*Suffix of the model number "***" each indicates ④Relief Pressure Setting and ⑤Filter Rating.

DIMENSIONS

(Typical/Motor Type: A3)

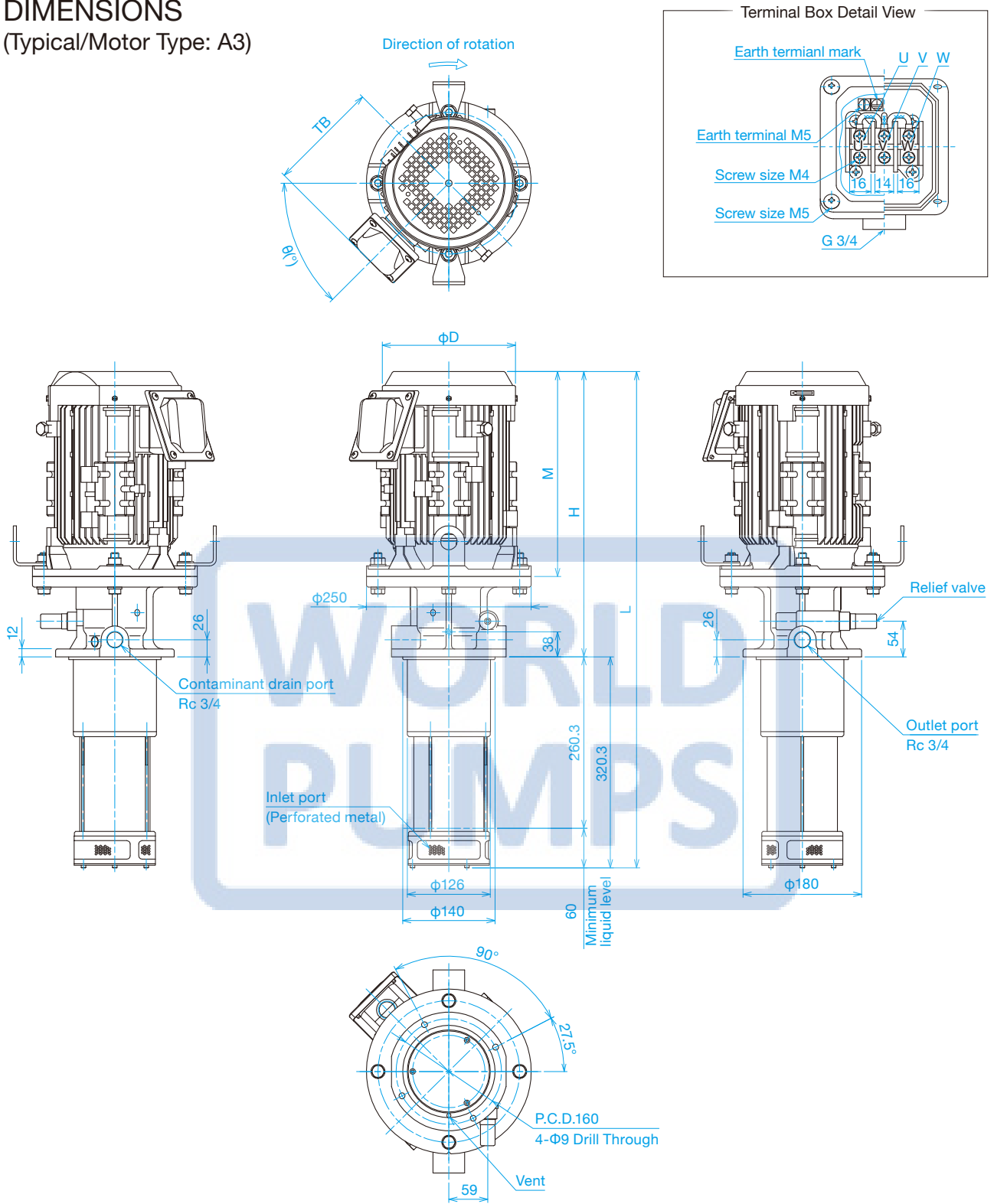

(mm)

Model	L	H	M	φD	θ(°)	TB
YTH2200A3-P008EVD70*	753.3	433	311	202	45	168
YTH2200A3-P010EVD**						
YTH2200A3-P016EVD**						
YTH3700A3-P014EVD70*	768.3	448	326	243		187
YTH3700A3-P016EVD**						

*Drawings in PDF format can be downloaded from NOP filter pump website.

FEATURES OF YTH-EP

An All-in-one, High-to-medium Pressure Coolant Unit

All components of a coolant system are consolidated into a single pump. No inline and suction filters are required. The saved space expands the available plant space, resulting in a higher production efficiency.

- Maximum operating pressure: 7.0 MPa.
- Maximum flow rate: 28.8 liters/min.
- No suction filter is required.
- No inline filter is required.
- No plumbing is required to interconnect various components.

Turbulence™ Filter

Our special Turbulence™ design generates turbulence around the surface of filter with 2 wing-shaped vanes rotating around filter and can wash away sludge from filter surface continuously.

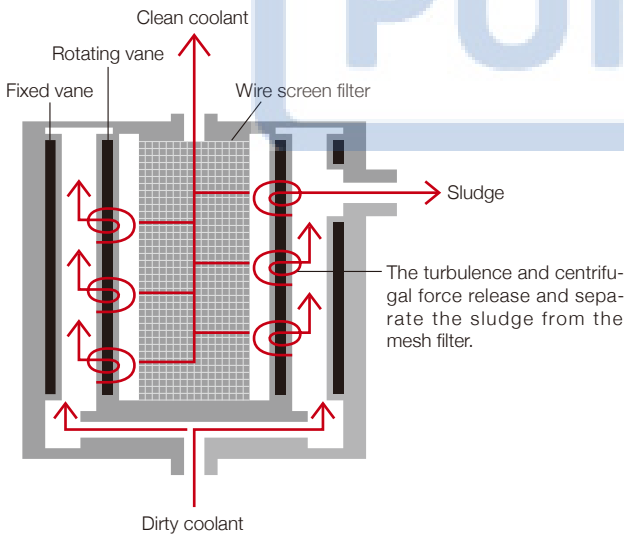

High Efficiency Plunger Pump

- Compatible fluid type
 - Water soluble coolant (Please consult us if you use non-water soluble coolant).
 - Incompatible with lubricant oils, fuel oils.
 - Incompatible with clear water, demineralized water, aqueous solutions and viscous fluids without rust-preventive property, corrosive fluids, solvents, and any cutting fluids that contain active sulfur.
- Relief valve is built into the pump.

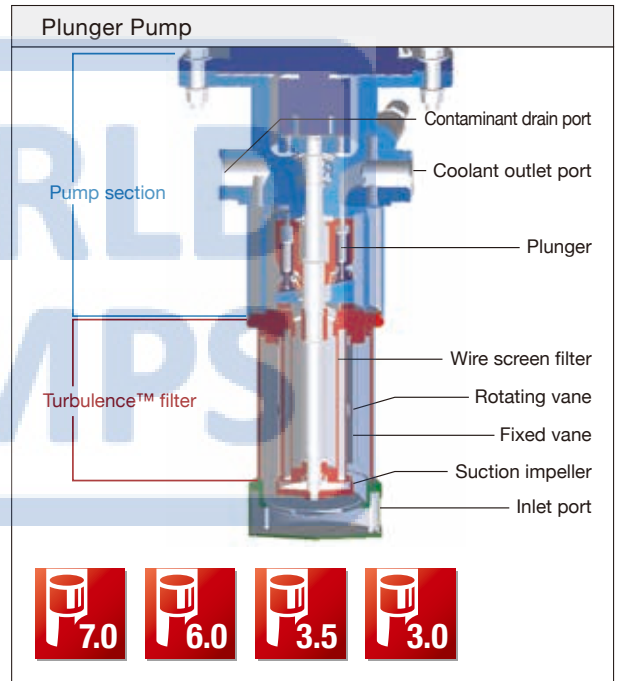

Filter Rating (Nominal value)

Suction strainer	3 mm (Solids larger than this must be removed from the tank.)
Filter	20 μm, 50 μm

*Please consult us if you use non-water soluble coolant.

SAMPLE SYSTEM LAYOUT

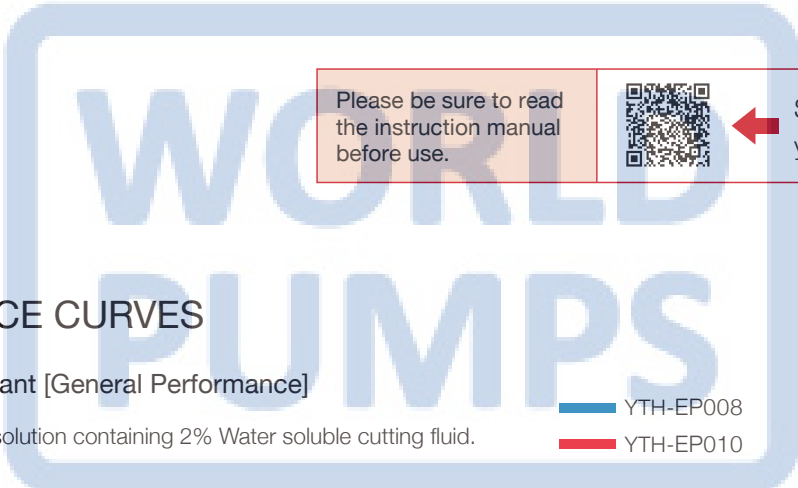
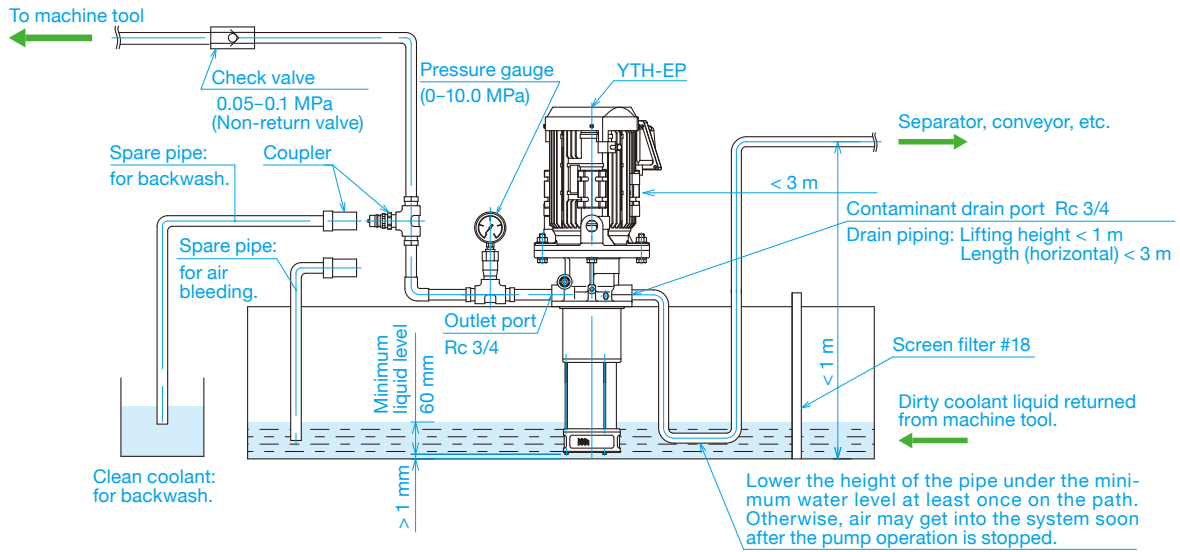

Please be sure to read the instruction manual before use.



Scan with your mobile device !

PERFORMANCE CURVES

Water Soluble Coolant [General Performance]

Test oil: JIS K2241 A3 solution containing 2% Water soluble cutting fluid.

- YTH-EP008
- YTH-EP014
- YTH-EP010
- YTH-EP016

50 Hz

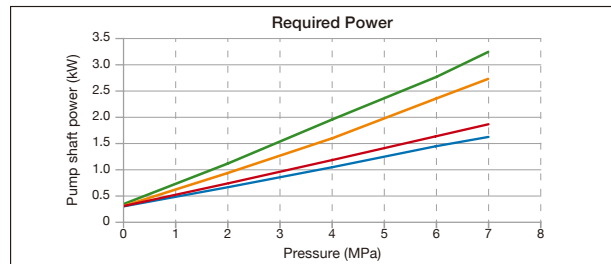
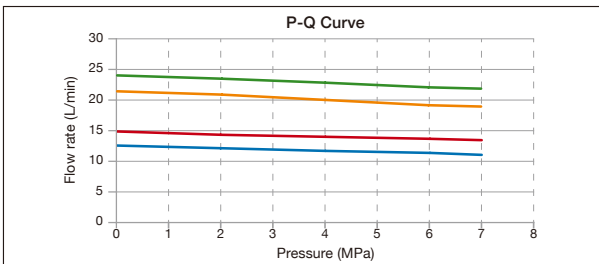

60 Hz

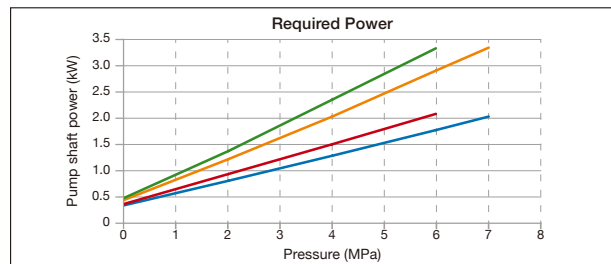
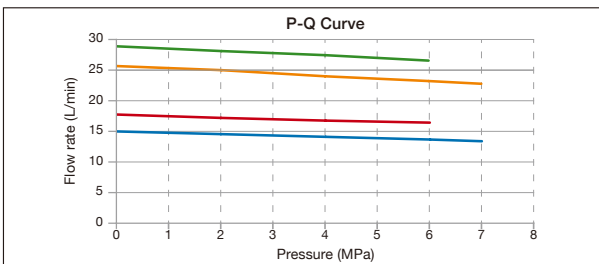

FEATURES OF YTH-EP LINE TYPE

*The model number of Line type ends with capital letter "L." The pump specification is the same as YTH-EP.

NOP Filter Pump External Type

Unlike normal type that can only be installed upon a coolant tank, this external type can be installed independently in a distant place with an extension pipe.
Alteration of tank cover is no longer necessary, allowing quick and easy retrofitting.

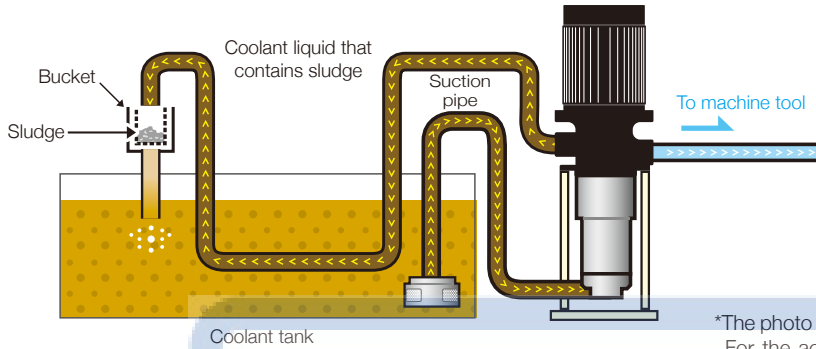

*The photo is for illustration purposes only. For the actual appearance, please refer to the drawing on P.14.

SAMPLE SYSTEM LAYOUT

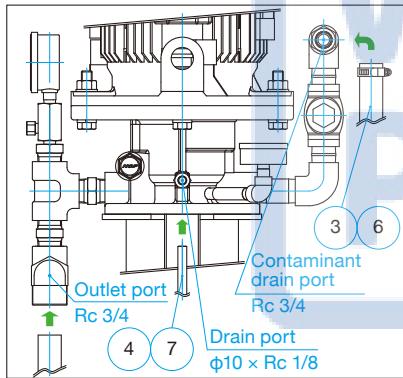

Parts List					
Item No.	Description	Qty.	Hose size (ID × OD)	Hose ripple	Note
①	Suction strainer (ASSY)	1	—	φ32 × R1-1/4	Insert a screen filter to ensure that pump doesn't directly suck foreign objects larger than the size of strainer perforations. Secure the strainer to the tank to prevent air suction.
②	Suction hose (3m)	1	φ32 × φ41	(φ32 × R1-1/4)	The hose should be as short as possible with minimum number of bends.
③	Contaminant drain hose (3m)	1	φ19 × φ26	(φ19 × R 3/4)	Lower the height of the hose under the water level at least once on the path as illustrated below to prevent air from flowing back into the system. Do not restrict the flow to 20 L/min or lower. The hose outlet should be secured as far away as possible from the strainer.
④	Drain tube (3m)	1	φ7.5 × φ10	(φ10 × R 1/8) (One touch joint)	Release the liquid from contaminant drain port in open atmosphere. (Make sure that the hose-end does not touch the liquid surface.) The liquid from the drain hose will drop with its own weight, so the hose should be as short as possible with minimum number of bends.
⑤	Hose clamp (φ32)	2	—	—	Tighten the hose clamp securely to prevent leaks.
⑥	Hose clamp (φ19)	2	—	—	Tighten the hose clamp securely to prevent leaks.
⑦	Tube insert (φ10)	1	—	—	Secure the tube insert tightly to prevent leaks.
⑧	Spare hose for air bleeding (3m)	1	φ19 × φ26	(φ19 × R 1/2)	Use this only when performing air-bleeding on the first run. (It will become unnecessary once the pump has primed.)
⑨	Spare coupler for air bleeding (ASSY)	1	—	φ19 × R 1/2	Use this only when performing air-bleeding on the first run. (It will become unnecessary once the pump has primed.)

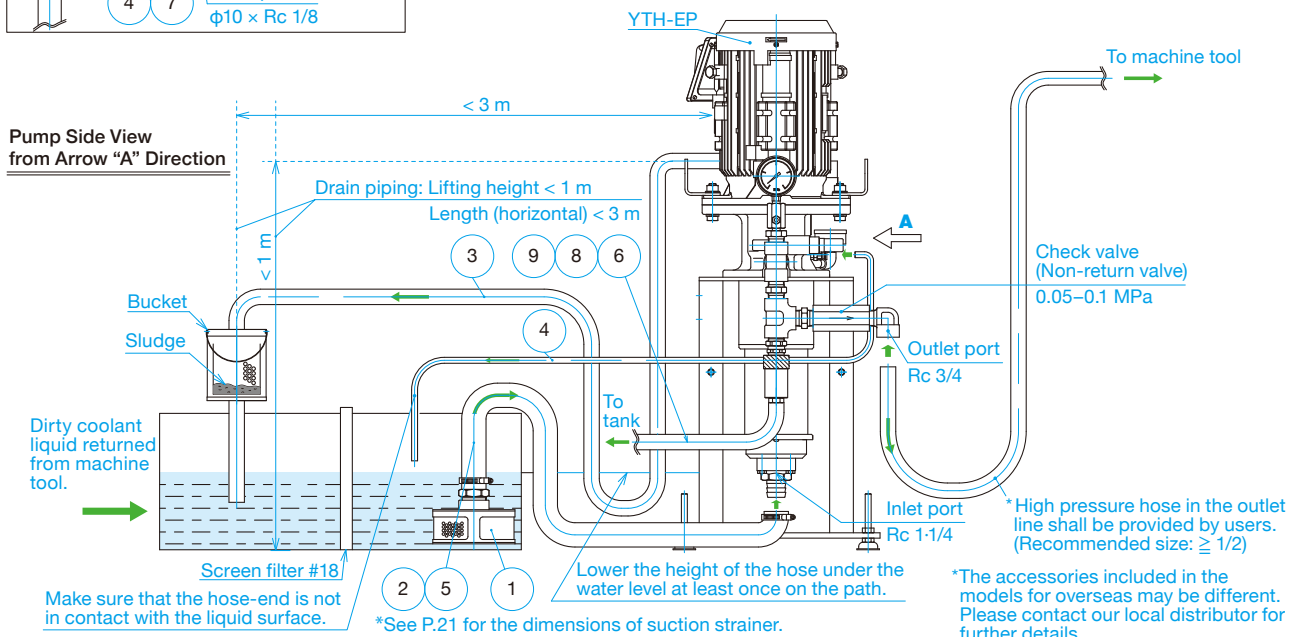

Please be sure to read the instruction manual before use.



Scan with your mobile device !

DIMENSIONS (Typical/Motor Type: A3)

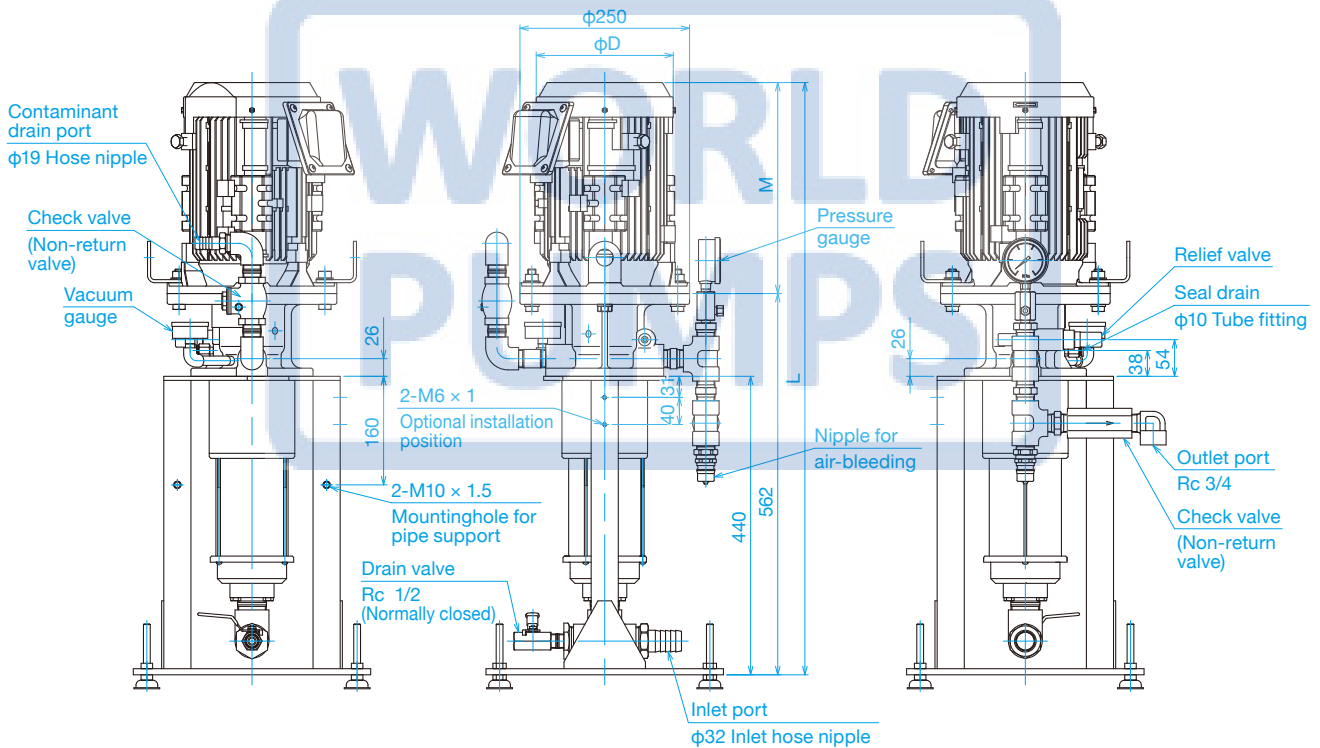
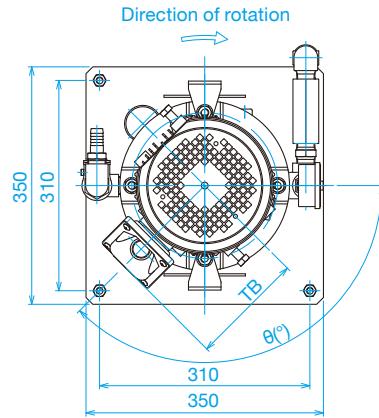
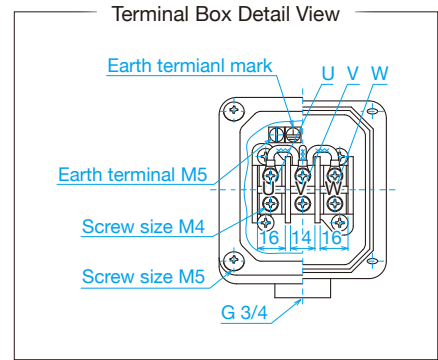

(mm)

Model	L	M	φD	θ(°)	TB
YTH2200A3-P008EVD70CL	873	311	202	135	168
YTH2200A3-P010EVD*CL					
YTH2200A3-P016EVD*CL					
YTH3700A3-P014EVD70CL	888	326	243		187
YTH3700A3-P016EVD*CL					

*Drawings in PDF format can be downloaded from NOP filter pump website.

YTH-ES

Received the "2015 JSME Excellent Product Award"

Trochoid™ Type Medium Pressure Unit

Turbulence™ Filter

Special turbulence cleans the filter automatically, rendering the filter clog free.

Trochoid™ pump/2.0 MPa, 1.5 MPa

A rotor turning in a trochoidal curve generates pressure to suck and discharge fluid. This is an extremely efficient self-priming pump.

Compatible with the TAZUNA™ fluid control system (software)

TAZUNA reduces the electric power cost further by approximately 20%. The pressure and flow rate are automatically adjusted.



MODEL NUMBERING SYSTEM

TOP—YTH ① ② - ③ E VD ④ ⑤

①Motor Capacity	②Motor Type*1	③Pump Capacity (Trochoid™ pump)	E: Filtering Method	VD: Relief Valve	④Relief Pressure Setting*2	⑤Filter Rating
750: 0.75 kW 1500: 1.5 kW	[Standard Motor] A3: AC 200/200/220/230 V 50/60/60/60 Hz 3 phase electric induction motor (IE3) with CE marking [Local Motor] AE: supplied by NOP Germany AF: supplied by NOP Taiwan AJ: supplied by NOP Asia (China) AK: supplied by NOP India AU/AV: supplied by NOP North America (USA)	S208: 8 cc/rev S216: 16 cc/rev	Turbulence™ filter	External return type	20: 2.0 MPa 15: 1.5 MPa	B: 50 μm C: 20 μm*3

*1 For further details about the local motors, please contact our overseas branch or subsidiaries.

*2 See P.45 to select a model that satisfies your desired relief valve set pressure.

*3 20 μm filter can not be applied to non-water soluble coolant.

SPECIFICATIONS

Model	Motor Capacity (kW)	Flow Rate (L/min) 50 Hz/60 Hz	Maximum Pressure (MPa) 50 Hz/60 Hz	Approximate Weight (kg)
YTH750A3-S208EVD15*	0.75	12.0/14.4	1.5/1.5	34
YTH1500A3-S216EVD**	1.5	24.0/28.8	2.0/2.0	39

*Suffix of the model number "***" each indicates ④Relief Pressure Setting and ⑤Filter Rating.

DIMENSIONS

(Typical/Motor Type: A3)

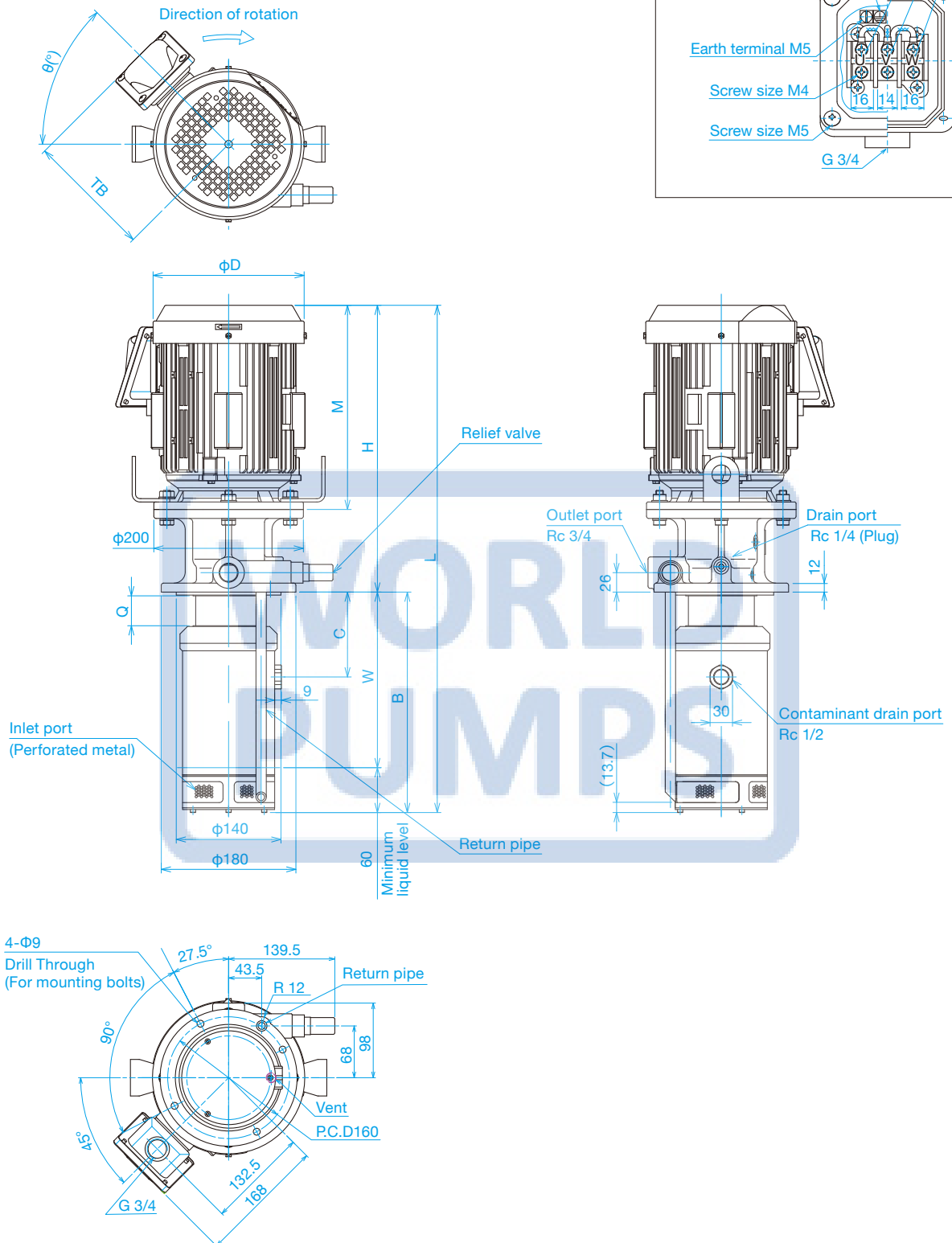

(mm)

Model	L	B	C	W	Q	H	M	ϕD	$\theta(^{\circ})$	TB
YTH750A3-S208EVD15*	638.8	274.8	93.5	214.8	20	364	253.5	170	30	151
YTH1500A3-S216EVD**	678.3	294.8	113.5	234.8	40	383.5	273	202	45	168

*Drawings in PDF format can be downloaded from NOP filter pump website.

FEATURES OF YTH-ES

An All-in-one, Medium Pressure Coolant Unit

All components of a coolant system are consolidated into a single pump. No inline and suction filters are required. The saved space expands the available plant space, resulting in a higher production efficiency.

- Maximum operating pressure: 2.0 MPa.
- Maximum flow rate: 28.8 liters/min.
- No suction filter is required.
- No inline filter is required.
- No plumbing is required to interconnect various components.



Turbulence™ Filter

Our special Turbulence™ design generates turbulence around the surface of the filter with 2 wing-shaped vanes rotating around the filter and can wash away sludge from the filter surface continuously.

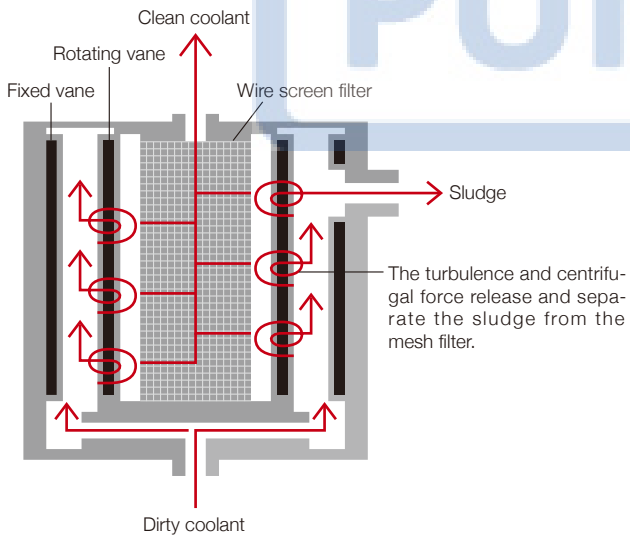

High Efficiency Trochoid™ Pump

- Compatible fluid type
 - Water soluble coolant, non-water soluble coolant.
 - Incompatible with lubricant oils, fuel oils.
 - Incompatible with clear water, demineralized water, aqueous solutions and viscous fluids without rust-preventive property, corrosive fluids, solvents, oil-based materials.
- Relief valve is built into the pump.

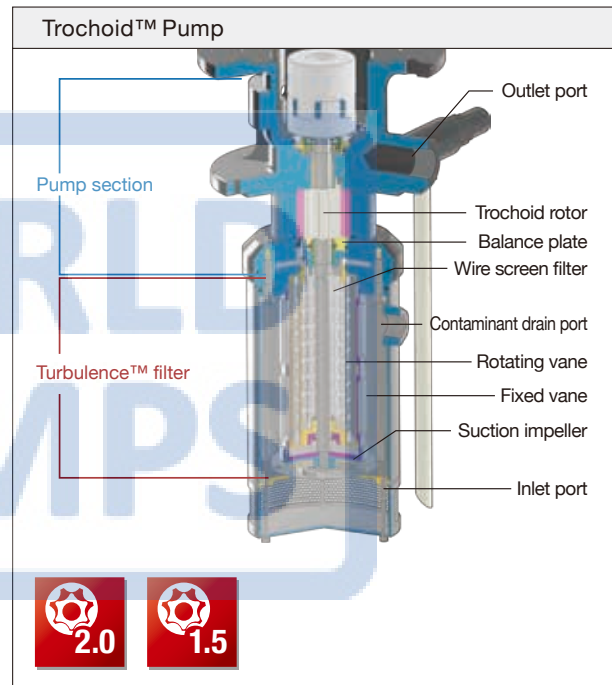

Filter Rating (Nominal value)

Suction strainer	3 mm (Solids larger than this must be removed from the tank.)
Filter	20 μm, 50 μm

YTH-ES Type (Wear-resistant Model)

For its special wear resistant structure, YTH-ES can be installed on coolant tanks of machines that generate hard and abrasive swarf.

- Balance Plate
 - Pump generates inner pressure to press the balance plate toward the Trochoid rotor side, which helps in reducing the clearance created by wear on rotor side and thereby minimize the pressure drop, ensuring desired performance for a longer time.
- Shaft and Bearing Reinforcement
 - Improved wear resistance by employing sprayed ceramic on shaft bearing area and use of ceramic bearing.
- Double Seal & Cartridge System
 - Seal area is reinforced to prevent leakage and cartridge system ensures ease of replacement.

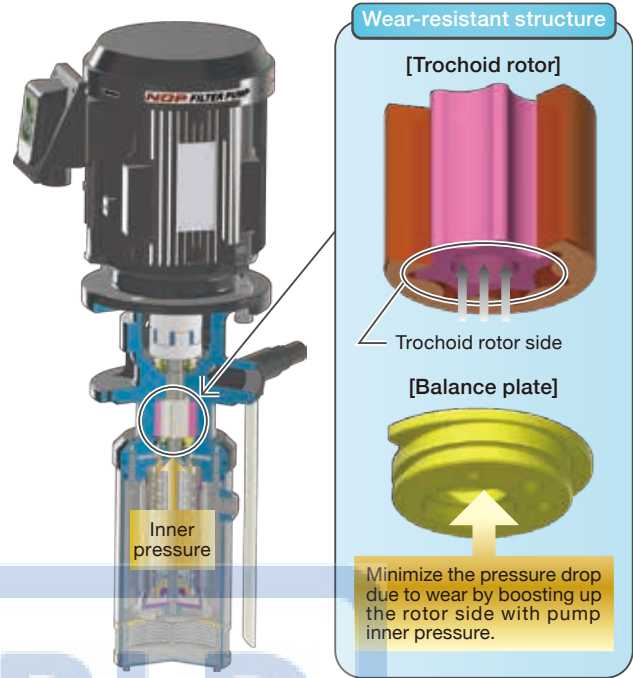

SAMPLE SYSTEM LAYOUT

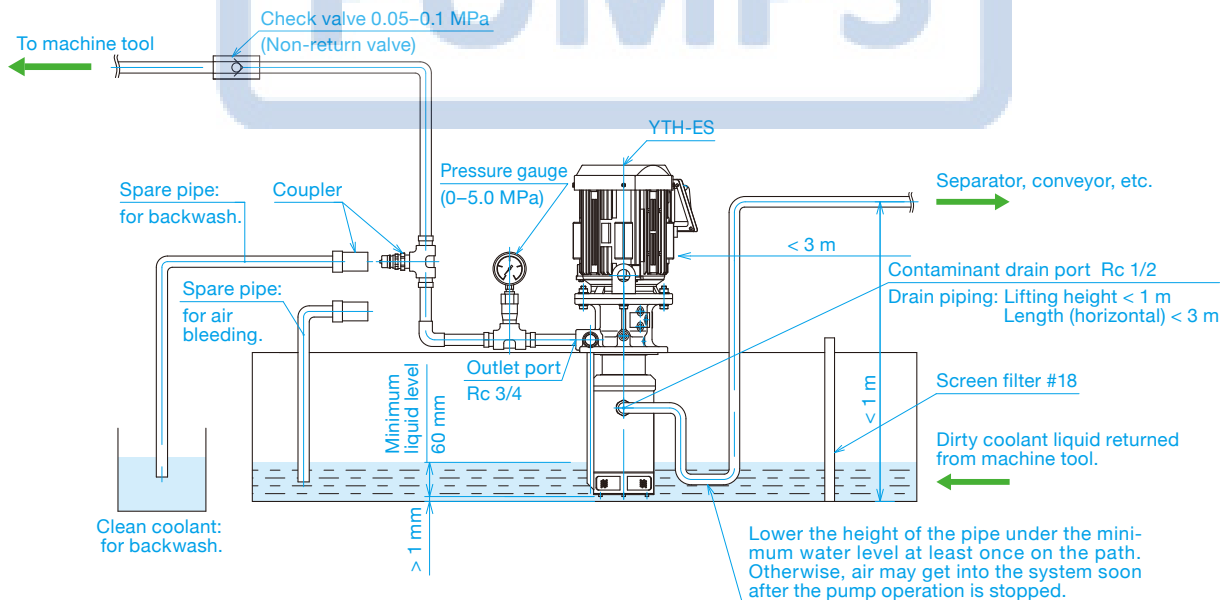

Please be sure to read the instruction manual before use.



Scan with your mobile device !

PERFORMANCE CURVES

Water Soluble Coolant [General Performance]

Test oil: JIS K2241 A3 solution containing 2% Water soluble cutting fluid.

YTH-ES208
YTH-ES216

50 Hz

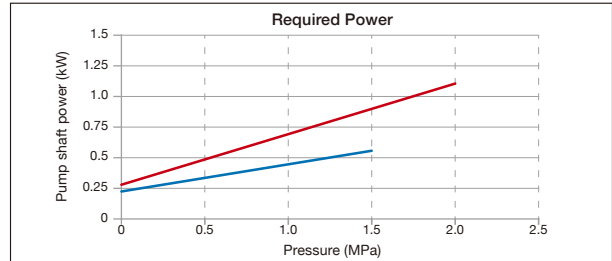
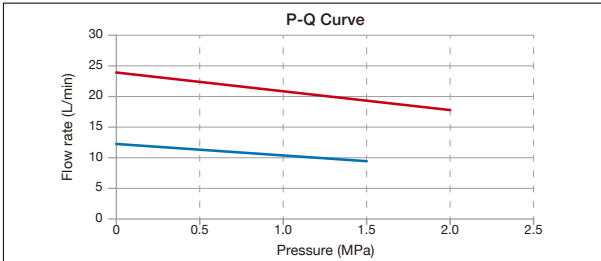

60 Hz

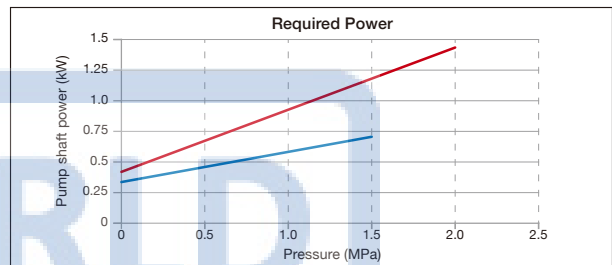
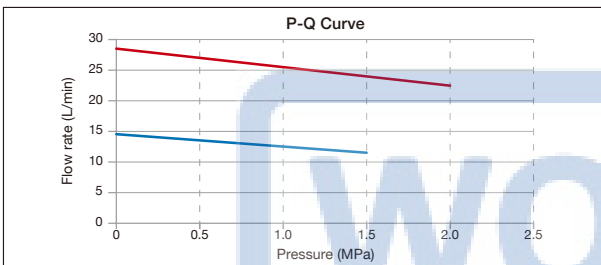

Spindle Oil [General Performance]

Test oil: ISO VG2 equivalent.

YTH-ES208
YTH-ES216

50 Hz

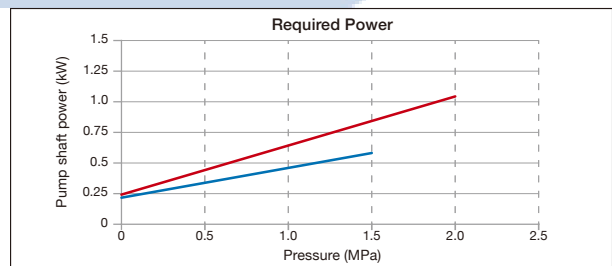
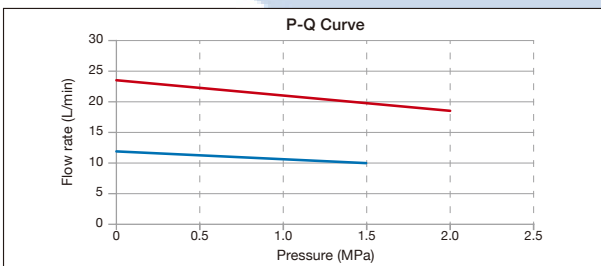

60 Hz

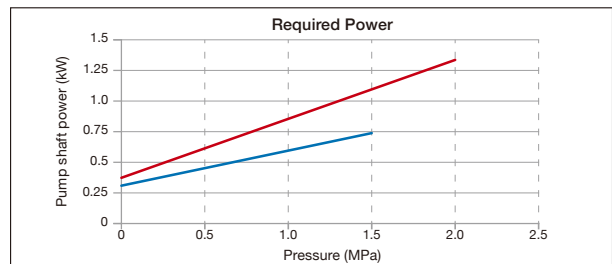
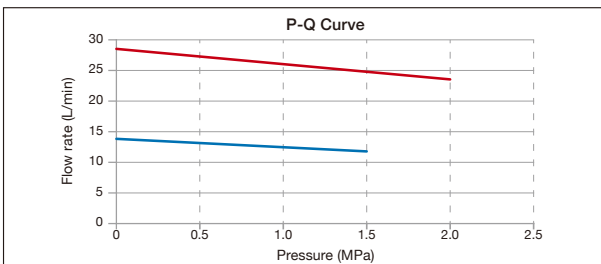

FEATURES OF YTH-ES LINE TYPE

*The model number of Line type ends with capital letter "L." The pump specification is the same as YTH-ES.

NOP Filter Pump External Type

Unlike normal type which can only be installed upon a coolant tank, this external type can be installed independently in a distant place with an extension pipe.

Alteration of tank cover is no longer necessary, allowing quick and easy retrofitting.

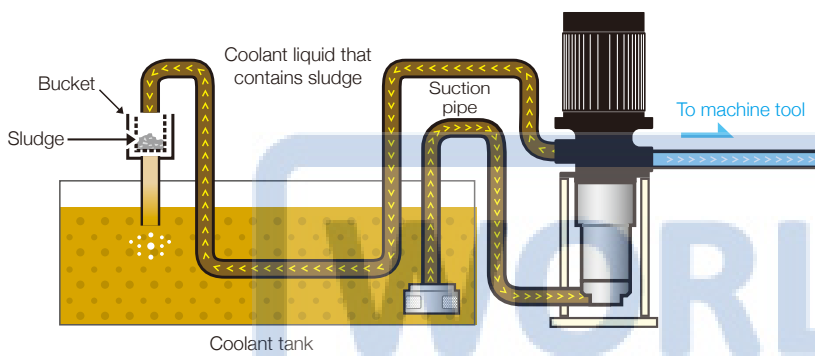

*The photo is for illustration purposes only. For the actual appearance, please refer to the drawing on P.22.

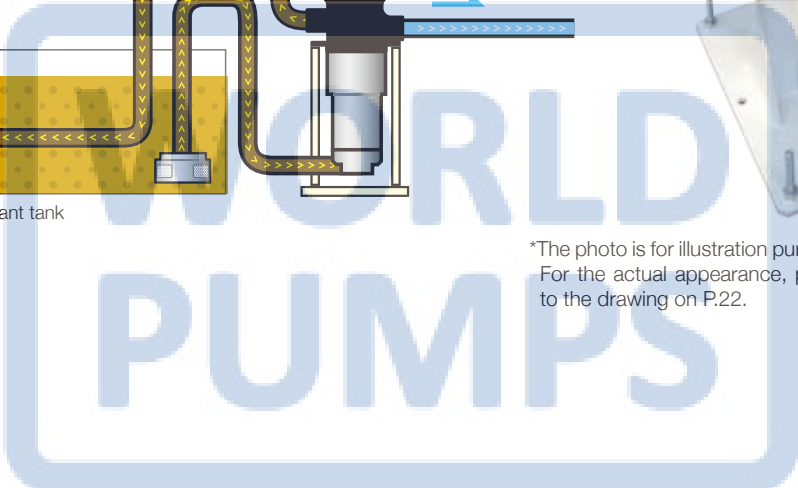

SAMPLE SYSTEM LAYOUT

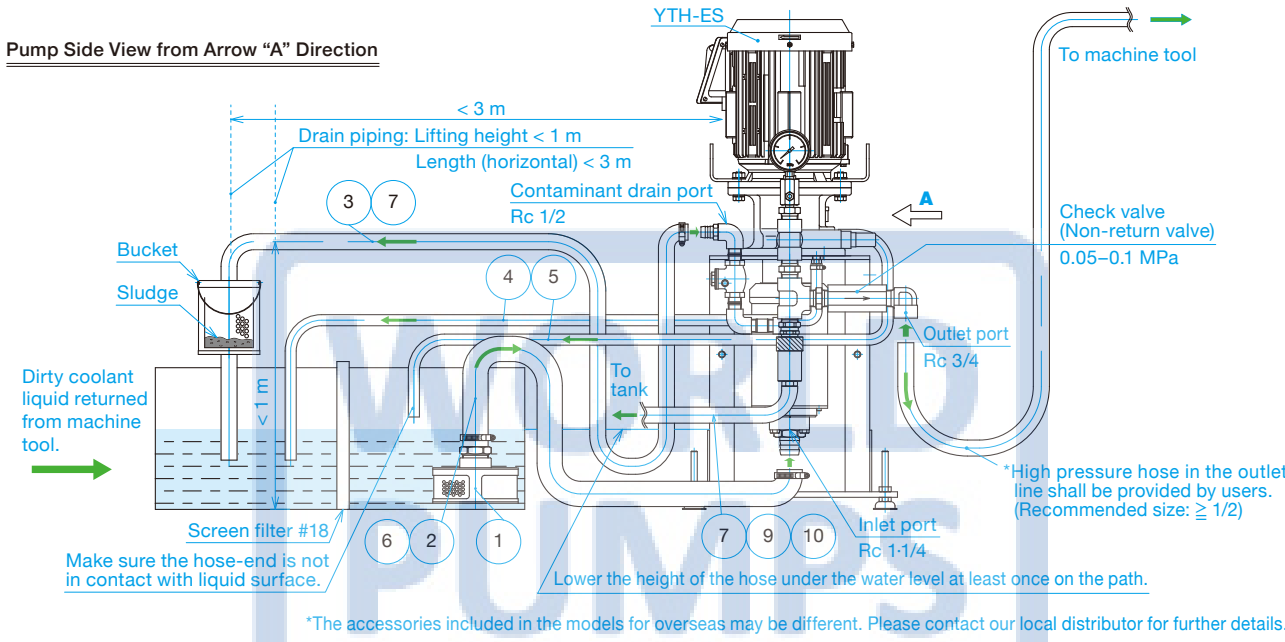
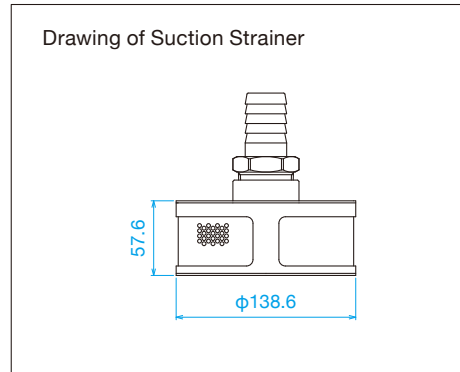
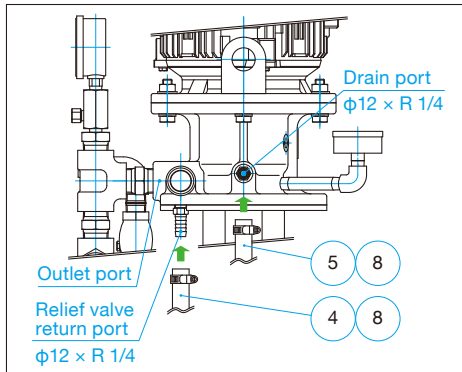

Parts List

Item No.	Description	Qty.	Hose size (ID × OD)	Hose nipple	Note
①	Suction strainer (ASSY)	1	—	φ32 × R 1-1/4	Insert a screen filter to ensure that pump doesn't directly suck foreign objects larger than the size of strainer perforations. Secure the strainer to the tank to prevent air suction.
②	Suction hose (3m)	1	φ32 × φ41	(φ32 × R 1-1/4)	The hose should be as short as possible with minimum number of bends.
③	Contaminant drain hose (3m)	1	φ19 × φ26	(φ19 × R 1/2)	Lower the height of the hose under the water level at least once on the path as illustrated below to prevent air from flowing back into the system. Do not restrict the flow to 20 L/min or lower.
④	Relief valve discharge hose (3m)	1	φ12 × φ18	(φ12 × R 1/4)	To prevent foam generation, make sure that the hose-end is secured underwater and as far as possible from pump suction area.
⑤	Drain hose (3m)	1	φ12 × φ18	(φ12 × R 1/4)	Release the liquid from contaminant drain port in open atmosphere. (Make sure that the hose-end does not touch the liquid surface.) The liquid from the drain hose will drop with its own weight, so the hose should be as short as possible with minimum number of bends.
⑥	Hose clamp (φ32)	2	—	—	Tighten the hose clamp securely to prevent leaks.
⑦	Hose clamp (φ19)	2	—	—	Tighten the hose clamp securely to prevent leaks.
⑧	Hose clamp (φ12)	1	—	—	Tighten the hose clamp securely to prevent leaks.
⑨	Spare hose for air bleeding (3m)	1	φ19 × φ26	(φ19 × R 1/2)	Use this only when performing air-bleeding on the first run. (It will become unnecessary once the pump has primed.)
⑩	Spare coupler for air bleeding (ASSY)	1	—	φ19 × R 1/2	Use this only when performing air-bleeding on the first run. (It will become unnecessary once the pump has primed.)

Please be sure to read the instruction manual before use.



Scan with your mobile device !

DIMENSIONS (Typical/Motor Type: A3)

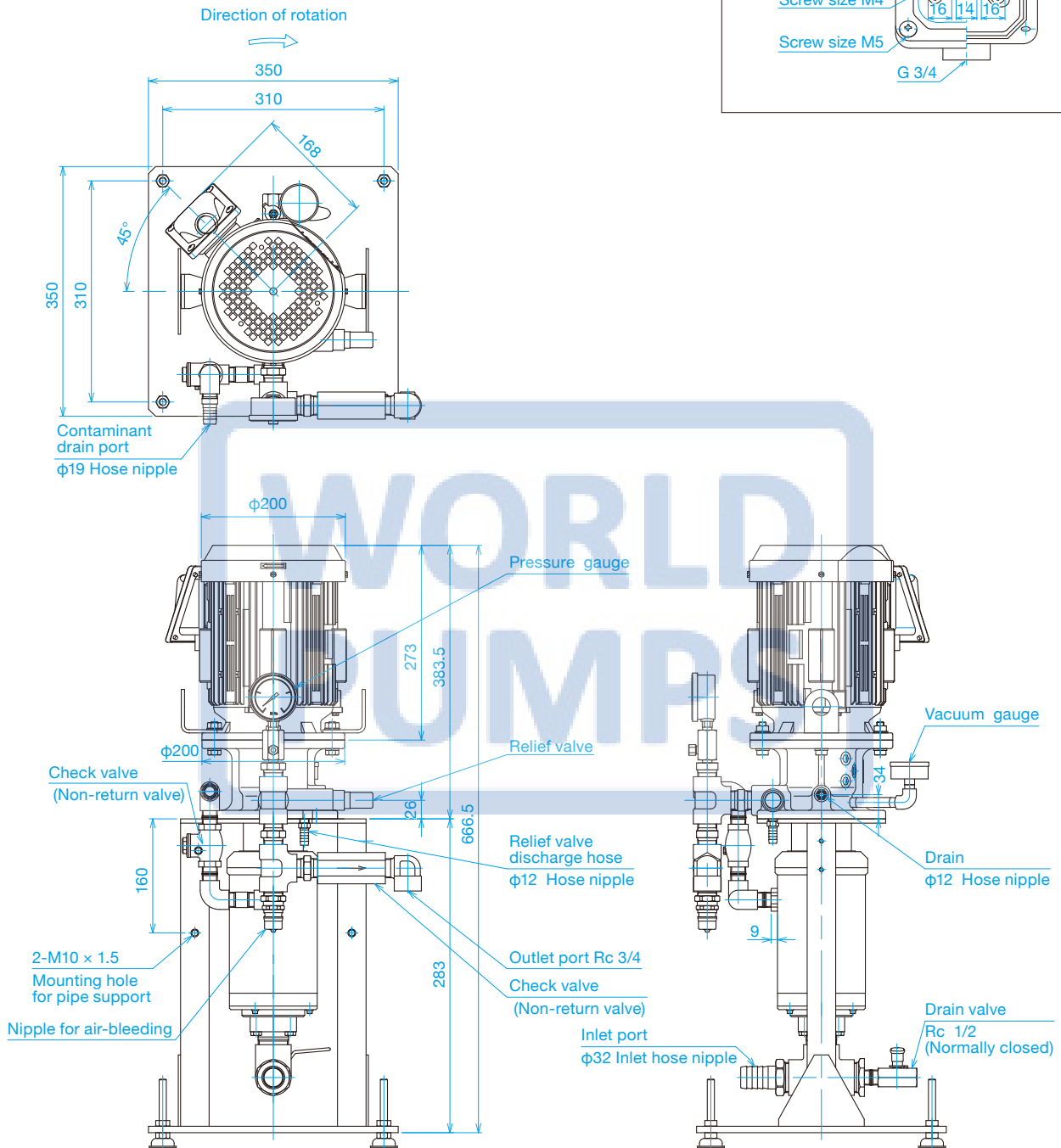

(mm)

Model	L	B	H	M	ϕD	$\theta(^{\circ})$	TB
YTH750A3-S208EVD15*L	756	392	364	253.5	170	30	151
YTH1500A3-S216EVD**L	823.5	440	383.5	273	202	45	168

YTH-CT/CS

Trochoid™ Type Medium Pressure Unit

Double-cyclone filter

Two layers of double cyclones (one large cyclone and six small cyclones) remove sludge from the coolant fluid.

Trochoid™ pump/2.0 MPa, 1.5 MPa

A rotor turning in a trochoidal curve generates pressure to suck and discharge fluid. This is an extremely efficient self-priming pump.

Compatible with the TAZUNA™ fluid control system (software)

TAZUNA™ reduces the electric power cost further by approximately 20%. The pressure and flow rate are automatically adjusted.



MODEL NUMBERING SYSTEM

TOP — YTH ① ② - ③ C VD ④

①Motor Capacity	②Motor Type*1	③Pump Capacity (Trochoid™ pump)	C: Filtering Method	VD: Relief Valve	④Relief Pressure Setting*2
750: 0.75 kW 1500: 1.5 kW	[Standard Motor] A3: AC 200/200/220/230 V 50/60/60/60 Hz 3 phase electric induction motor (IE3) with CE marking [Local Motor] AE: supplied by NOP Germany AF: supplied by NOP Taiwan AJ: supplied by NOP Asia (China) AK: supplied by NOP India AU/AV: supplied by NOP North America (USA)	T208: 8 cc/rev T216: 16 cc/rev S216: 16 cc/rev	Double cyclone	External return type	20: 2.0 MPa 15: 1.5 MPa

*1 For further details about the local motors, please contact our overseas branch or subsidiaries.

*2 The valve set pressure for model S216 is fixed at 2.0 MPa. 1.5 MPa is unavailable.

SPECIFICATIONS

Model	Motor Capacity (kW)	Flow Rate (L/min) 50 Hz/60 Hz	Maximum Pressure (MPa) 50 Hz/60 Hz	Approximate Weight (kg)
YTH750A3-T208CVD*	0.75	12.0/14.4	2.0/2.0	34
YTH1500A3-T216CVD*	1.5	24.0/28.8	2.0/2.0	39
YTH1500A3-S216CVD20	1.5	24.0/28.8	2.0/2.0	39

Suffix of the model number "" indicates ④Relief Pressure Setting.

DIMENSIONS

(Typical/Motor Type: A3)

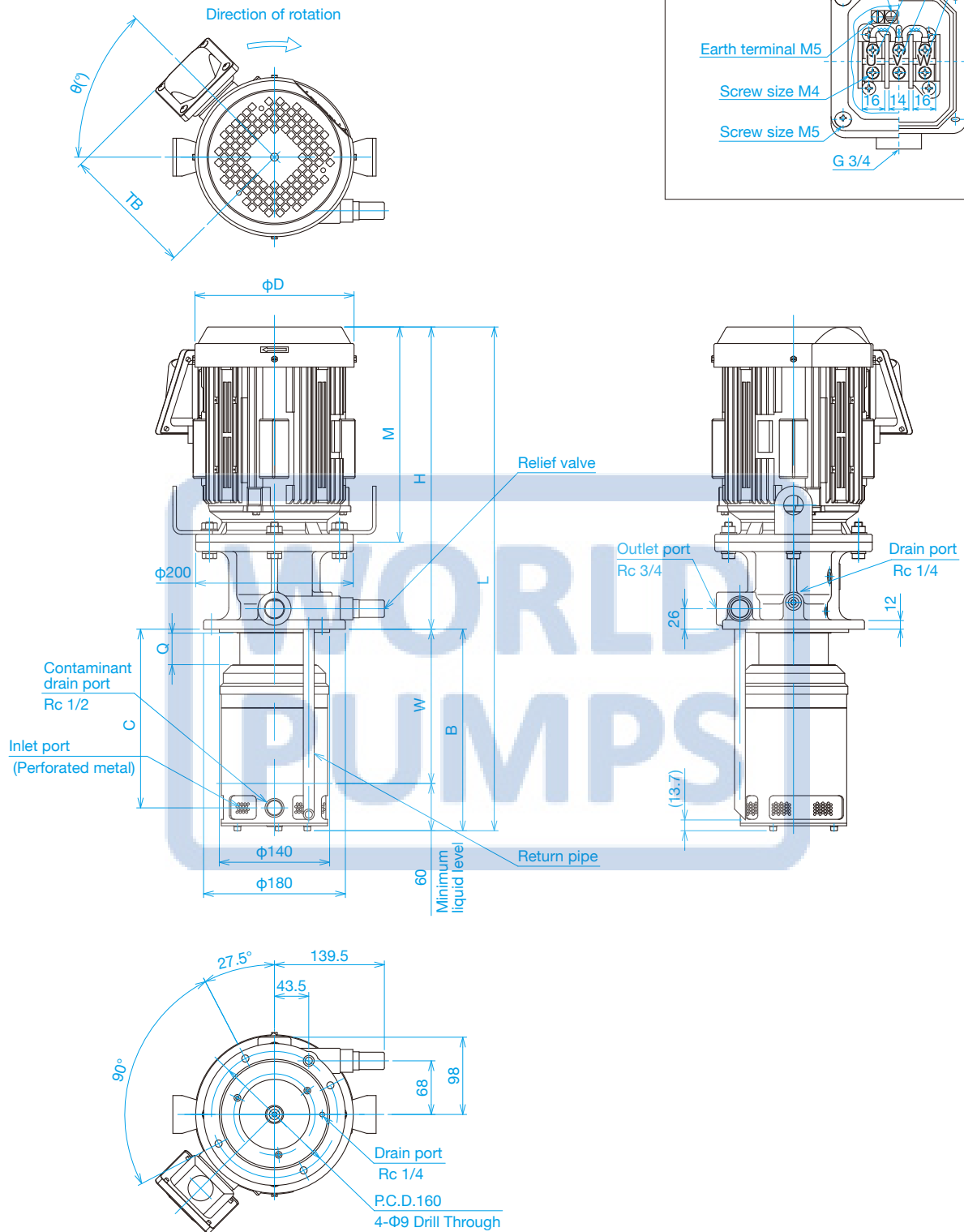

(mm)

Model	L	B	C	W	Q	H	M	ϕD	$\theta(^{\circ})$	TB
YTH750A3-T208CVD*	599.7	235.7	206.7	175.7	20	364	253.5	170	30	151
YTH1500A3-T216CVD*	639.2	255.7	226.7	195.7	40	383.5	273	202	45	168
YTH1500A3-S216CVD20	643.7	260.2	231.2	200.2	40	383.5	273	202	45	168

*Drawings in PDF format can be downloaded from NOP filter pump website.

FEATURES OF YTH-CT/CS

All-in-one Medium-pressure Coolant Pump

All components of a coolant system are consolidated into a single pump. The saved space expands the available plant space, resulting in a higher production efficiency.

- Maximum operating pressure: 2.0 MPa.
- Maximum flow rate: 28.8 liters/min.
- No suction filter is required.
- No plumbing is required to interconnect various components.

High Efficiency Trochoid™ Pump

CT employs a Trochoid™ pump which excels in fluid control efficiency. The double-cyclone system sorts out sludge and enables direct connection to the coolant tank.

- Compatible fluid type
 - Water soluble coolant.
 - Incompatible with non-water soluble coolant, lubricant oils, fuel oils.
 - Incompatible with clear water, demineralized water, aqueous solutions and viscous fluids without rust-preventive property, corrosive fluids, solvents, oil-based materials.



Double-cyclone Filter

A proprietary double-cyclone system removes sludge. The first cyclone removes larger debris, while the second cyclones remove smaller particles. The inline filter cleaning cycle is extended by 24 times.

*Sludge larger than 20 µm can be removed. (When using water-soluble coolant fluid.)

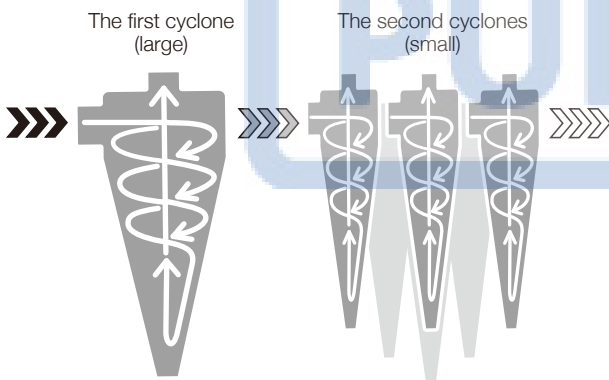

Cleaning of inline filter is reduced to once a month (On average)

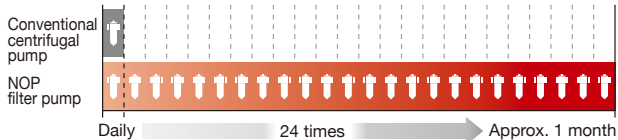

- Relief valve is built into the pump.

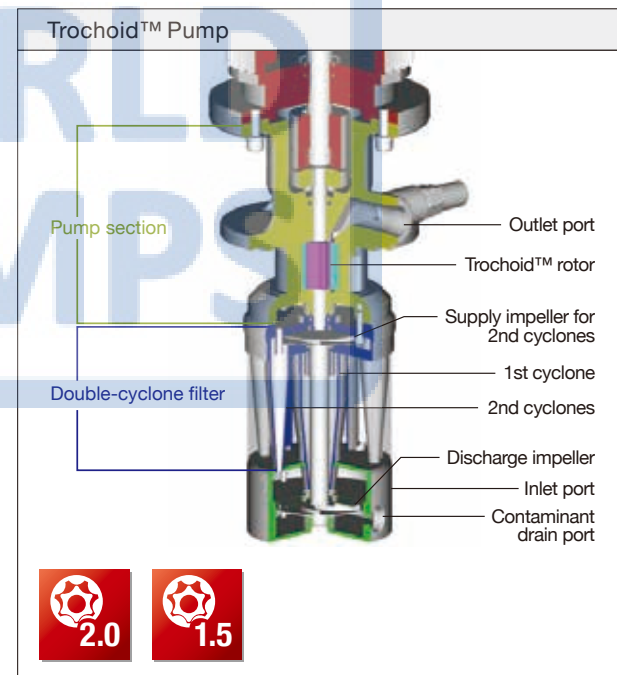

Filter Rating (Nominal value)

Suction strainer	3 mm (Solids larger than this must be removed from the tank.)
Filter	Water-soluble coolant fluid 50 µm: 95% (Specific weight 2.7) 100 µm: 99.9% (Specific weight 2.7)

*Be sure to install an unloading valve in the outlet pressure line if running the pump intermittently. (See P.28)

YTH-CS Type (Wear-resistant Model)

For its special wear resistant structure, YTH-CS can be installed on coolant tanks of machines that generate hard and abrasive swarf that YTH-CT cannot handle.

- Balance Plate
 - Pump generates inner pressure to press the balance plate toward the Trochoid rotor side, which helps in reducing the clearance created by wear on rotor side and thereby minimize the pressure drop, ensuring desired performance for a longer time.
- Shaft and Bearing Reinforcement
 - Improved wear resistance by employing sprayed ceramic on shaft bearing area and use of ceramic bearing.
- Double Seal & Cartridge System
 - Seal area is reinforced to prevent leakage and cartridge system ensures ease of replacement.

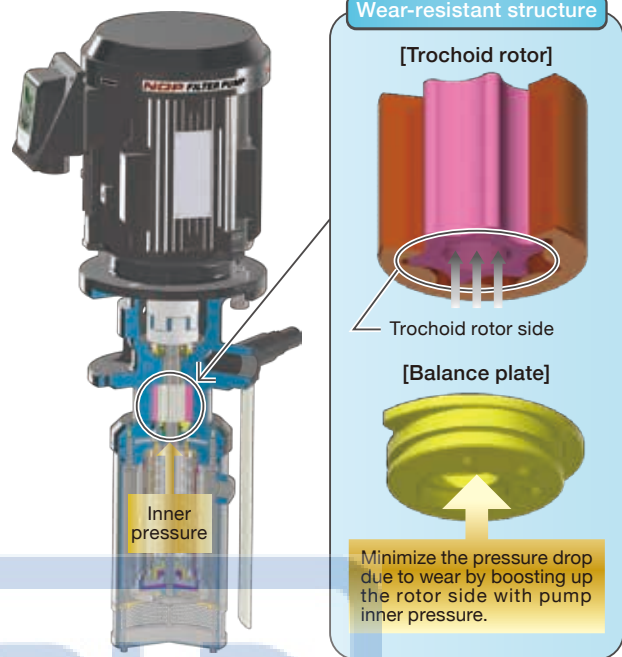

SAMPLE SYSTEM LAYOUT

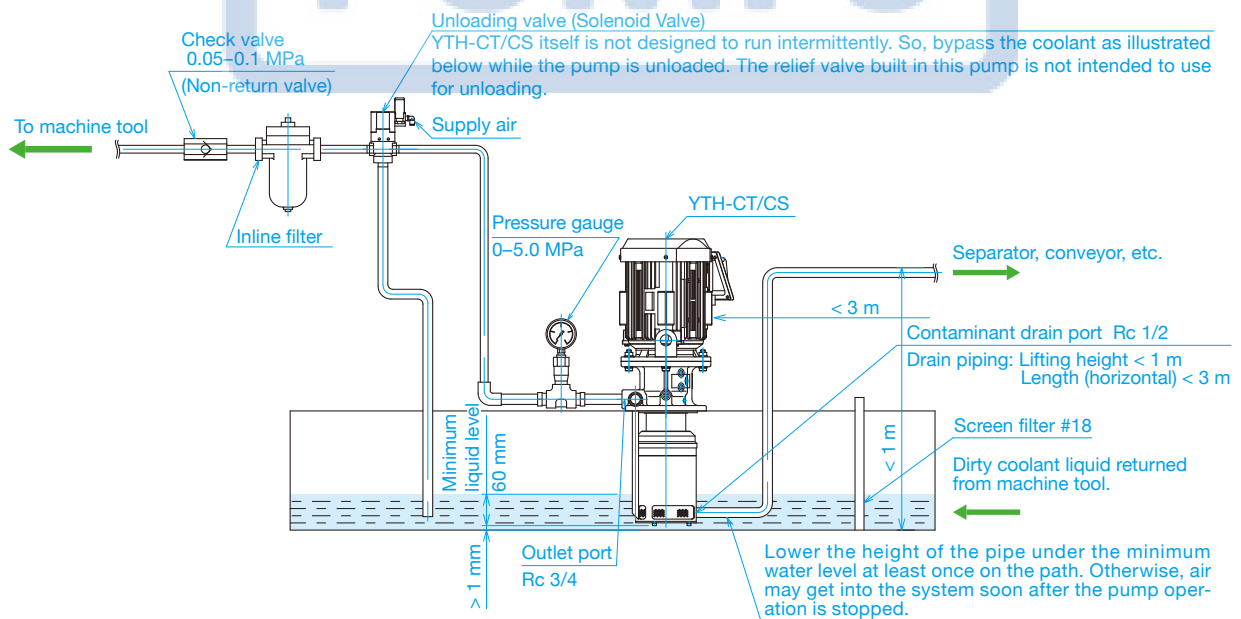

Please be sure to read the instruction manual before use.



(For CT)

← Scan with your mobile device ! →



(For CS)

PERFORMANCE CURVES (YTH-CT)

Water Soluble Coolant [General Performance]

Test oil: JIS K2241 A3 solution containing 2% Water soluble cutting fluid.

YTH-CT208
YTH-CT216

50 Hz

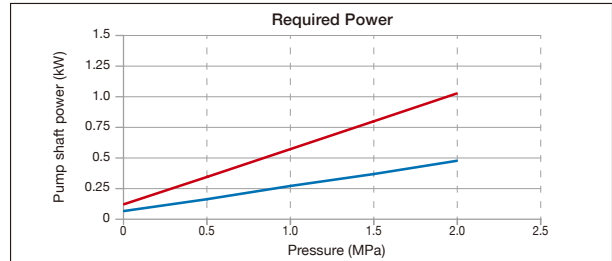
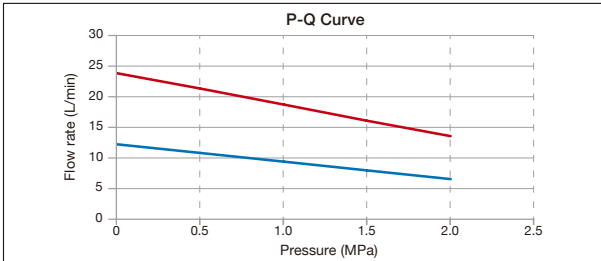

60 Hz

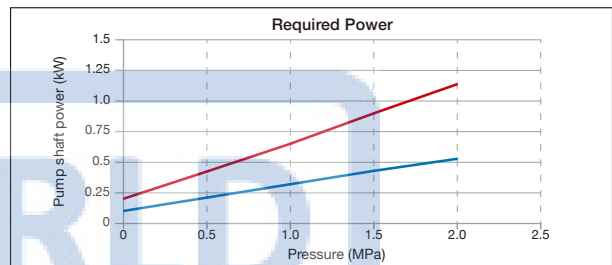
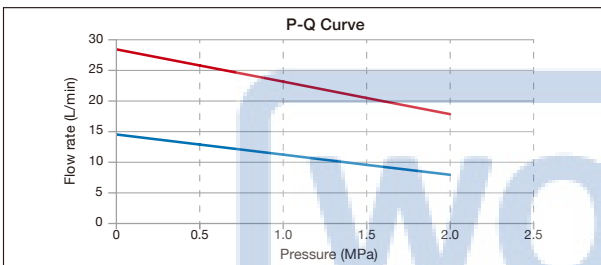

PERFORMANCE CURVES (YTH-CS)

Water Soluble Coolant [General Performance]

Test oil: JIS K2241 A3 solution containing 2% Water soluble cutting fluid.

YTH-CS216

50 Hz

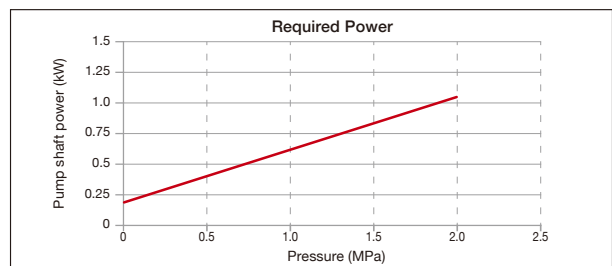
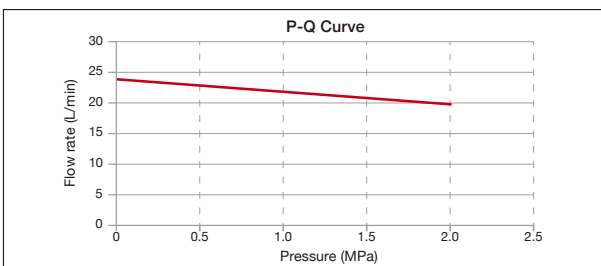

60 Hz

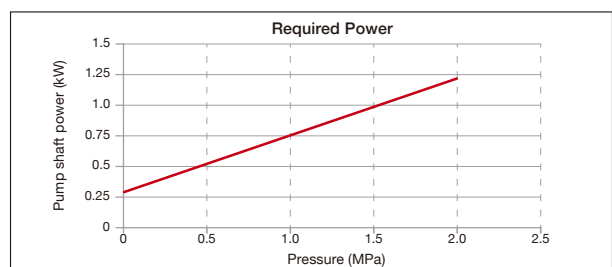
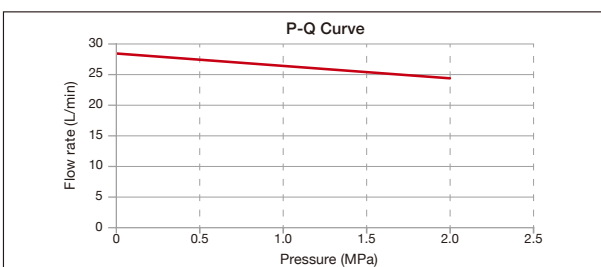

INLINE FILTER 27154601

Accessories

No.	Part Name	Qty	Drawing No./Model No.	Manufacturer
①	Inline filter	1	G-UL-04A-20UW-IK	Taisei Kogyo Co., Ltd.
②	Filter bracket for CS-L	1		
③	Pressure rubber hose 1/2 × 500 mm with metal fitting on both sides	1		
④	Hose adapter 15 A × G15 Elbow	2		
⑤	Hexagonal bolt M8 × 16 SCM trivalent chromate	4		

*The parts ②, ③, ④, ⑤ are all included in the product.

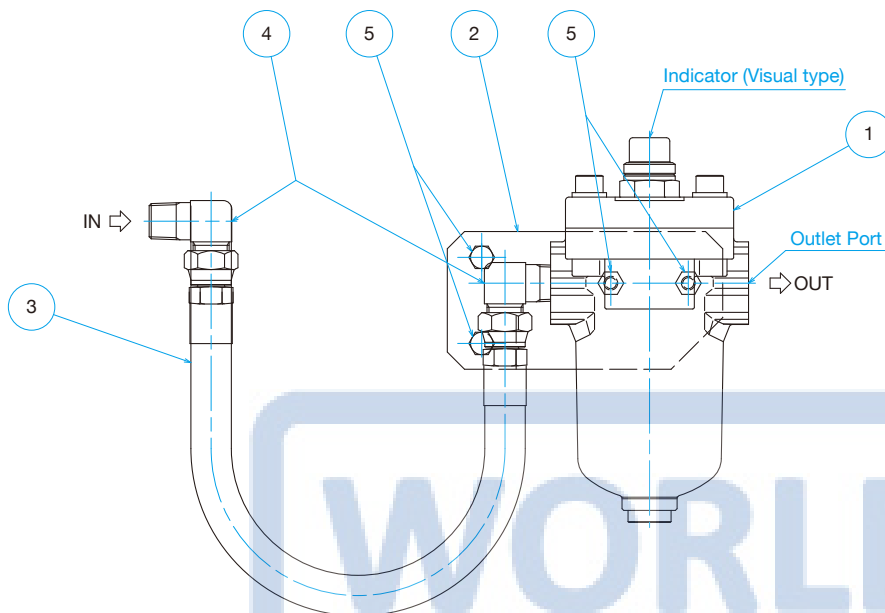

Filter Specification	
Compatible Liquid	Water-glycol fluid, etc.
Connection Port	Rc 1/2
Nominal Filtration Rating	20 μm
Indicator	Visual type (Working pressure: 0.3 MPa)
Relief Valve	Non
Surge Suppressor	Installed
Mating Flange	Non
Magnet	Non
Maximum Operating Pressure	3.5 MPa
Element Differential Pressure Resistance	0.7 MPa
Standard Flow Rate	50 L/min

UNLOADING VALVE 27154598

Accessories

No.	Part Name	Qty	Drawing No./Model No.	Manufacturer
①	Unloading valve	1	CVSE3-15A-35-B2GS-3	CKD
②	High pressure nipple 15 A	1		
③	Hose nipple Φ19 × 15 A	2		

*The parts ②, ③ are all included in the product.

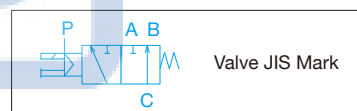

Electrical Specifications	
Required Power	2.0 W
Heat Resistance Class	130 (B)
Protection Level	IPX5 (IEC 529)

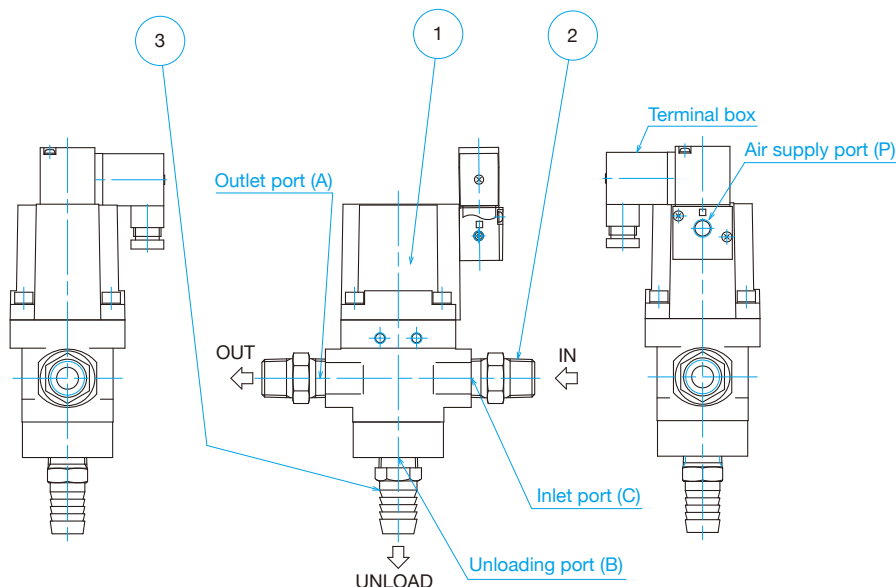

FEATURES OF YTH-CS LINE TYPE

*The model number of Line type ends with capital letter "L." The pump specification is the same as YTH-CS.

NOP Filter Pump External Type

Unlike normal type which can only be installed upon a coolant tank, this external type can be installed independently in a distant place with an extension pipe.

Alteration of tank cover is no longer necessary, allowing quick and easy retrofitting.

SAMPLE SYSTEM LAYOUT

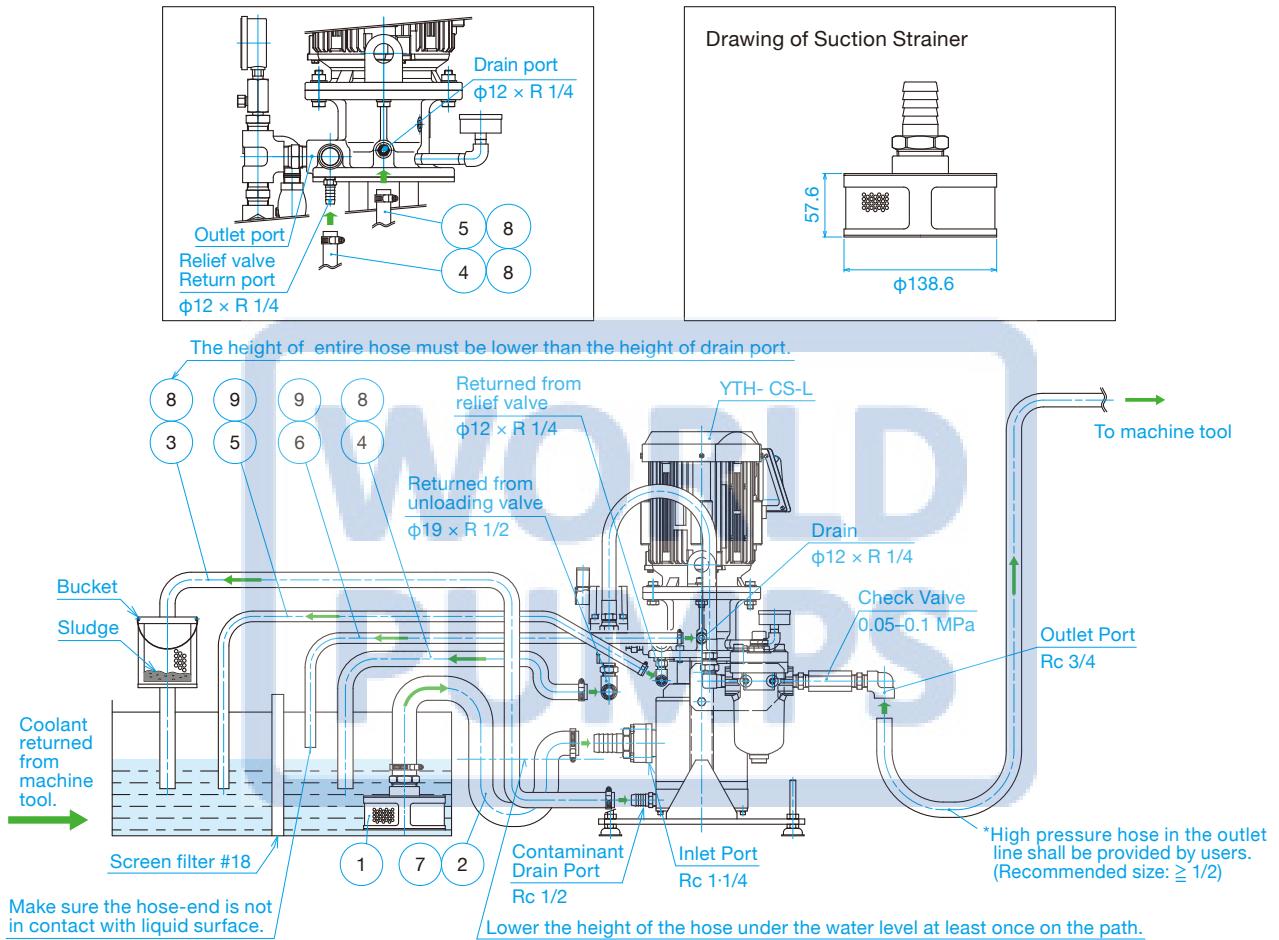

Parts List

Item No.	Description	Qty.	Hose size (ID x OD)	Hose nipple	Note
①	Suction strainer	1	—	R 1-1/4	Insert a screen filter to ensure that pump doesn't directly suck foreign objects larger than the size of strainer perforations. Secure the strainer to the tank to prevent air suction.
②	Suction hose (3m)	1	φ32 x φ41	R 1-1/4	The hose should be as short as possible with minimum number of bends.
③	Contaminant drain hose (3m)	1	φ19 x φ26	R 1/2	Do not restrict the flow to 20 L/ min or lower.
④	Unloading valve discharge hose (3m)	1	φ19 x φ26	R 1/2	The hose should be as short as possible with minimum number of bends.
⑤	Relief valve discharge hose (3m)	1	φ12 x φ18	R 1/4	To prevent foam generation, make sure that the hose-end is secured underwater and as far as possible from pump suction area.
⑥	Drain hose (3m)	1	φ12 x φ18	R 1/4	Release the liquid from contaminant drain port in open atmosphere. (Make sure that the hose-end does not touch the liquid surface.) The liquid from the drain hose will drop with its own weight, so the hose should be as short as possible with minimum number of bends.
⑦	Hose clamp (φ32)	2	—	—	Tighten the hose clamp securely to prevent leaks
⑧	Hose clamp (φ19)	2	—	—	Tighten the hose clamp securely to prevent leaks
⑨	Hose clamp (φ12)	2	—	—	Tighten the hose clamp securely to prevent leaks

Please be sure to read the instruction manual before use.



Scan with your mobile device !

DIMENSIONS (Typical/Motor Type: A3)

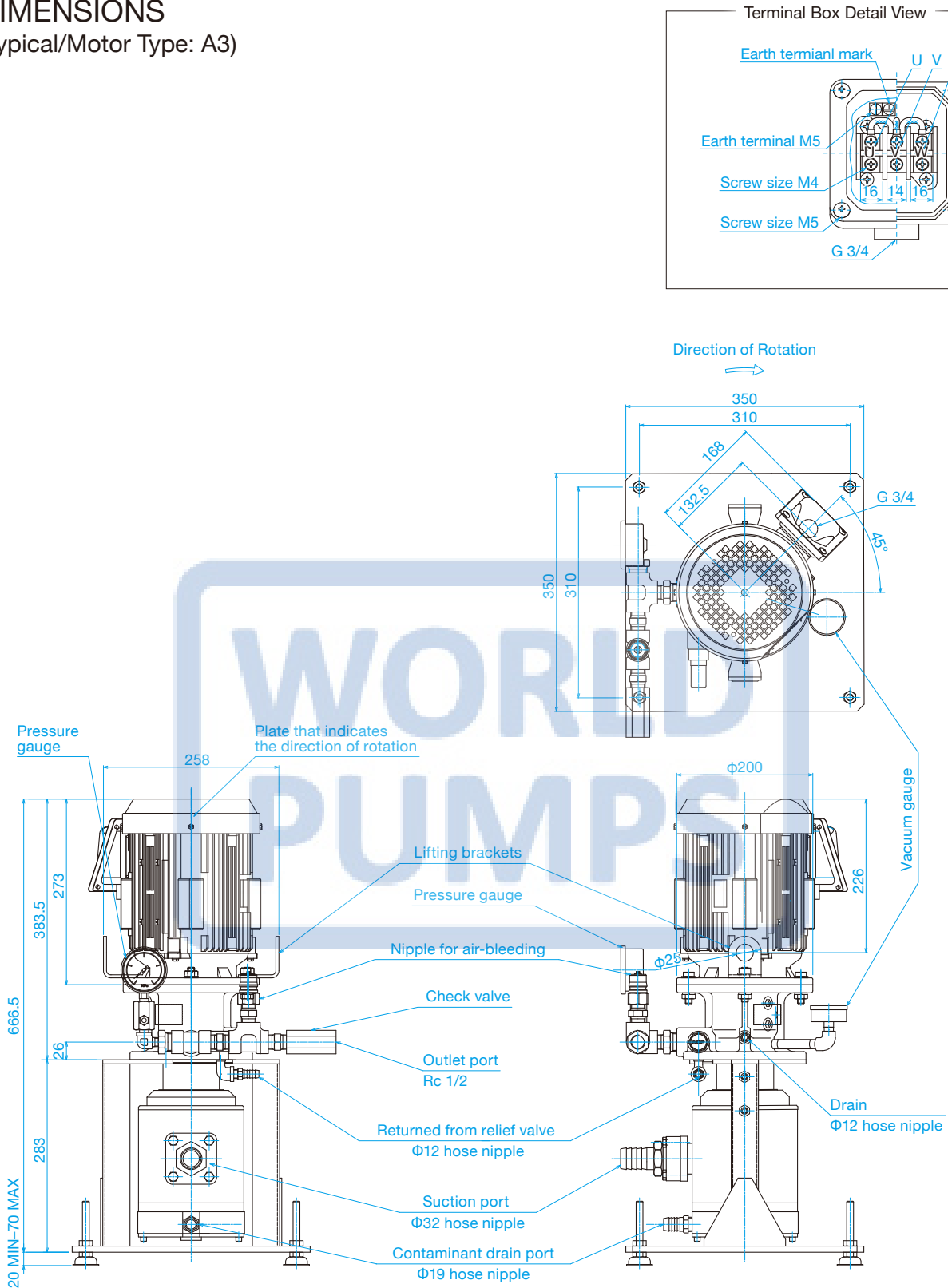

In addition to the parts shown in the figure above, inlet hose, contaminant drain hose, return hose from relief valve, return hose from unloading valve, seal drain tube (3 m each) and hose clamps are included.

*The accessories included in the models for overseas may be different. Please contact our local distributor for further details.

[CAUTION]

Hoisting must be carried out by qualified personnel in accordance with safety standards and requirements. Never use these brackets for anything other than their intended purpose.

(mm)

YTH-CI

Large Flow Low Pressure Coolant Unit with Built-in Cyclone Filter

Cyclone Filter

The cyclone system effectively removes sludge from the coolant.

Impeller Pump

The impellers spin and accelerate the liquid, thereby generating pressure inside the pump. This pump is designed to transfer large flow of liquid.



MODEL NUMBERING SYSTEM

TOP – YTH ① ② - ③

Motor Capacity	Motor Type	Pump Capacity* (Impeller Pump)
1500: 1.5 kW 3700: 3.7 kW	AC: AC 200/200/220/230V 50/60/60/60Hz 3 phase electric induction motor (IE3) with CE marking	I155C: 150 L (5 stages) with 50 Hz motor I152C: 150 L (2 stages) with 60 Hz motor I305C: 300 L (5 stages) with 50 Hz motor I302C: 300 L (2 stages) with 60 Hz motor

*I155C, I305C can not be operated at 60 Hz.

SPECIFICATIONS

Model	Motor Capacity (kW)	Voltage (V)	Frequency (Hz)	Approvals	Flow Rate (L/min)	Total Pump Head (m)	Approximate Weight (kg)
YTH1500AC-I155C	1.5	200	50	IE3, CE	150	55	43
YTH1500AC-I152C	1.5	200/220/230	60	IE3, CE	150	40	43
YTH3700AC-I305C	3.7	200	50	IE3, CE	300	65	70
YTH3700AC-I302C	3.7	200/220/230	60	IE3, CE	300	45	69

DIMENSIONS
(Typical/Motor Type: AC)

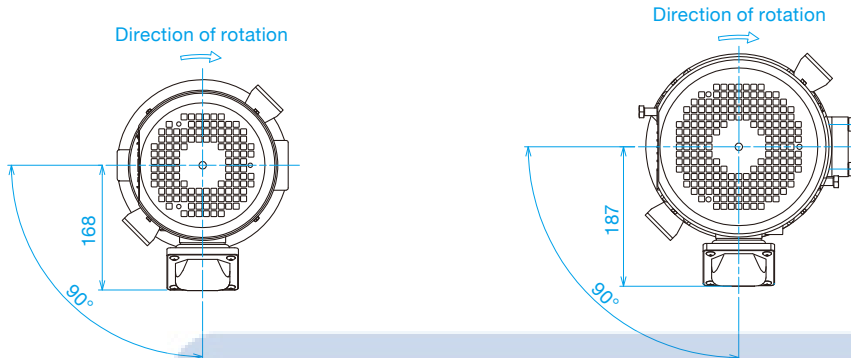
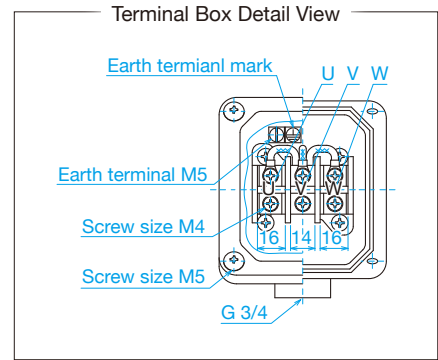

There are upper and lower mounting positions on the pump. Select either one in accordance with the depth of your tank.

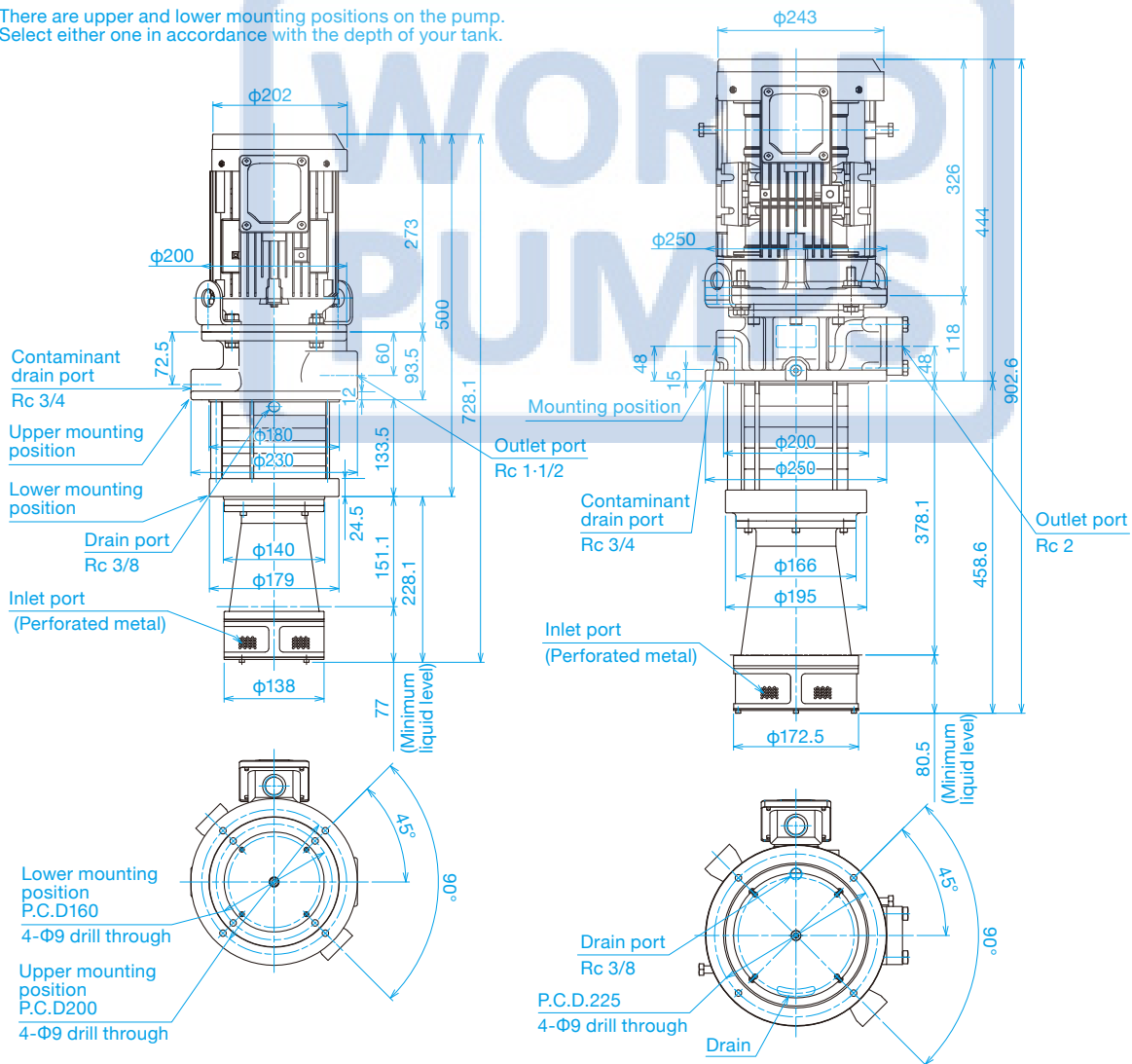

*If mounting the pump at lower position, be sure to do proper drain piping.

150 L Type

300 L Type

(mm)

YTH-GCI

Large Flow Low Pressure Coolant Unit with Built-in Cyclone Filter

Cyclone Filter

The cyclone system effectively removes sludge from the coolant.

Impeller Pump

The impellers spin and accelerate the liquid, thereby generating pressure inside the pump. This pump is designed to transfer large flow of liquid.



MODEL NUMBERING SYSTEM

TOP – YTH ① ② - ③

Motor Capacity	Motor Type	Pump Capacity* (Impeller Pump)
1100: 1.1 kW 1500: 1.5 kW 2200: 2.2 kW	R1/R2/R3/R4/R5/R6/R7 See the "MOTOR SPECIFICATIONS" table below for the voltage, frequency, approvals	I075CG: 70 L (5 stages) with 50 Hz motor I073CG: 70 L (3 stages) with 60 Hz motor I135CG: 135 L (5 stages) with 50 Hz motor I132CG: 135 L (2 stages) with 60 Hz motor I303CG: 300 L (3 stages) with 50 Hz motor I302CG: 300 L (2 stages) with 60 Hz motor

*I075CG, I155C, I305C can not be operated at 60 Hz.

SPECIFICATIONS

Model	Motor Capacity (kW)	Motor Type	Flow Rate (L/min)	Total Pump Head (m)	Approximate Weight (kg)
YTH1100**-I075CG	1.1	R1, R3, R4, R5	70	50	28.3
YTH1100**-I073CG	1.1	R2, R3, R6, R7	70	45	27.3
YTH1500**-I135CG	1.5	R1, R3, R4, R5	135	50	40
YTH1500**-I132CG	1.5	R2, R3, R6, R7	135	35	40
YTH2200**-I303CG	2.2	R1, R3, R4, R5	300	45	70
YTH2200**-I302CG	2.2	R2, R3, R6, R7	300	40	69

MOTOR SPECIFICATIONS

Motor Type	Voltage (V)	Frequency (Hz)	Approvals
R1	415	50	IE3, CE
R2	230	60	UL, CC, CE
R3	200	50/60	IE3, CE
R4	400	50	IE3, CE

Motor Type	Voltage (V)	Frequency (Hz)	Approvals
R5	380	50	GB2, CCC, CE
R6	440	60	UL, CC, CE
R7	220	60	IE3, CE

DIMENSIONS

(Typical/Motor Type: A3)

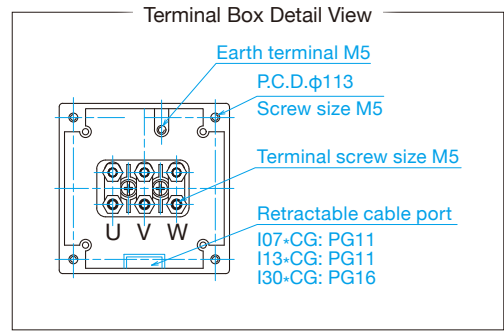

There are upper and lower mounting positions on the pump. Select either one in accordance with the depth of your tank.

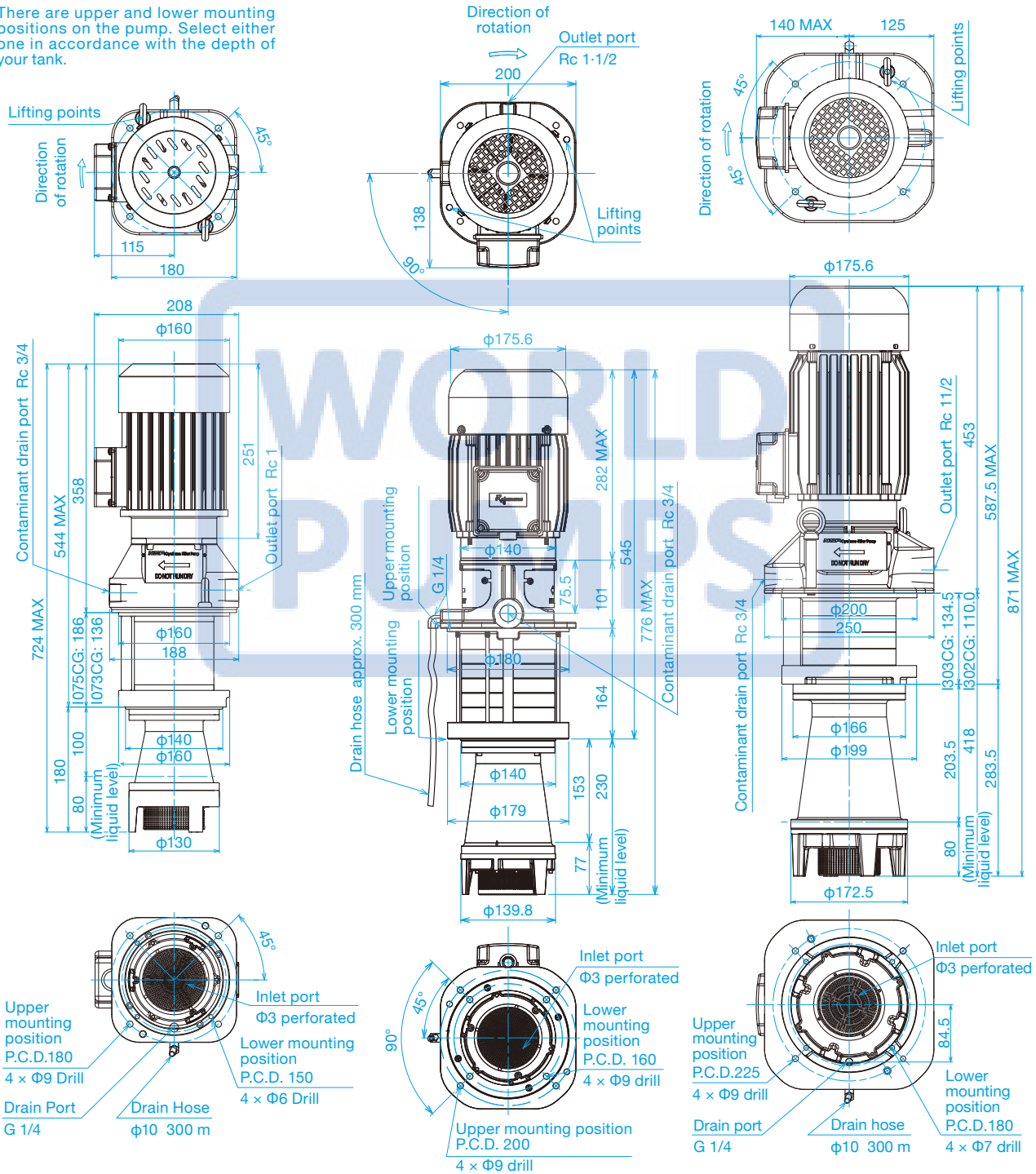

70 L Type

135 L Type

300 L Type

(mm)

*Drawings in PDF format can be downloaded from NOP filter pump website.

<https://filter-pump.nopgroup.com/en>

FEATURES OF YTH-CI/GCI

Large Flow Low Pressure Coolant Unit

YTH-CI/GCI is designed to deliver large flow at low pressure with built-in cyclone filter. Its compact design enables easy retrofitting to your existing tank of NC lathe, machining center or grinding machine, etc.

The large flow also ensures high efficiency in sludge removal, which substantially reduces problems around the tank, such as dimensional deviation of workpieces, clogged plumbing due to excessive accumulation of sludge.

- Total Pump Head: 35–65 m
- Maximum Flow Rate: CI 15°C: 150 L/min
 CI 30°C: 300 L/min
 GCI 07°C: 70 L/min
 GCI 13°C: 135 L/min
 GCI 30°C: 300 L/min



Cyclone Filter

This unique reversed cyclone system can separate clean coolant and dirty coolant inside the pump. Dirty coolant is pushed up through the side surface of cyclone filter by centrifugal force and discharged with sludge. Filtered clean coolant is collected to the center of cyclone filter and boosted up by multiple-stage impellers.

Filter Rating (Nominal value)

Suction strainer	3 mm (Solids larger than this must be removed from the tank)
Cyclone filter	Water soluble coolant 100 µm: 99.9% (Specific weight 2.7) Straight oil 100 µm: ≥ 80% (Specific weight 2.7)

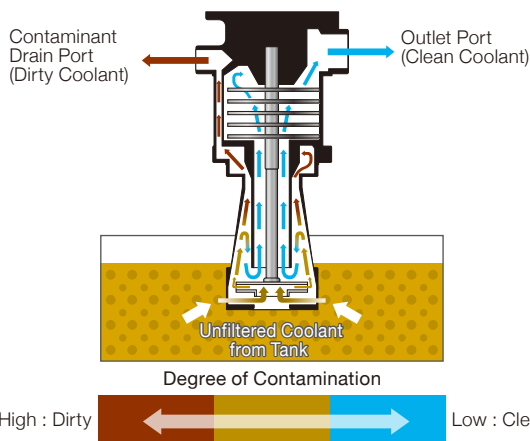

Impeller Pump

YTH-CI/GCI employs impellers whose design is best suited for supplying large quantity of coolant and capable of boosting up pressure with its multiple stage impellers.

- Compatible fluid type
 - Water soluble cutting fluids.
 - Non-water soluble coolant with kinematic viscosity of 22 mm²/s or less.
 - Incompatible with lubricant oils and fuel oils.
 - Incompatible with clear water, demineralized water, aqueous solutions and viscous fluids which do not offer rust-protection, corrosive fluids and solvents.

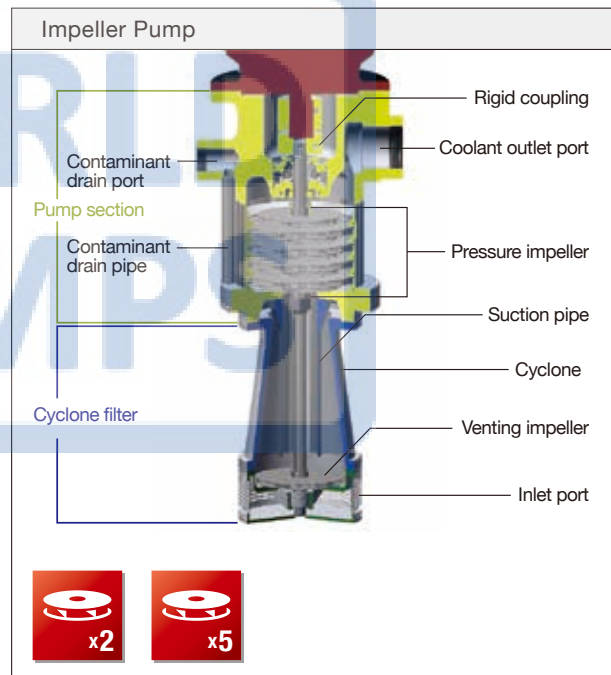

How Sludge is Separated (DEMO VIDEO)



Scan with your mobile device !

SLUDGE COLLECTION WITH YTH-CI/GCI

STEP 1

Install YTH-CI/GCI in a way that filtered clean coolant from the outlet port can circulate all around the tank.

STEP 2

Proper agitation of the tank by following STEP 1 can prevent sludge precipitation in the tank. YTH-CI/GCI can also collect sludge floating in the tank and discharge from the contaminant drain port.

STEP 3

Discharged sludge can be collected with YTH wire mesh bucket or a settling tank.

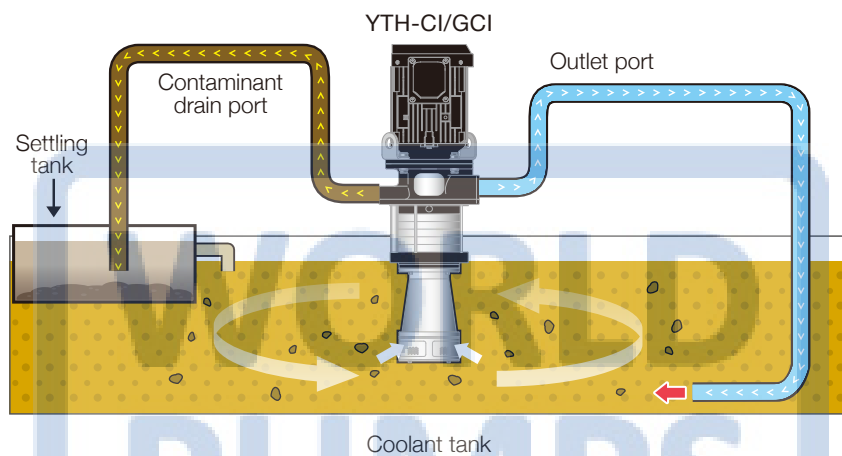

[How Sludge is Collected with YTH-GCI]

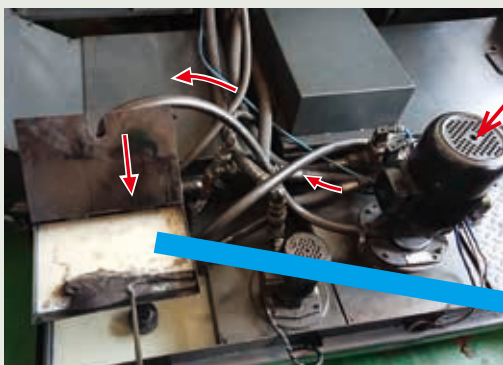

The large flow low pressure unit is discharging sludge.

YTH-GCI



Sludge in the tank that was collected by the large flow low pressure unit.

How Sludge is Collected with YTH-GCI (DEMO VIDEO)

Scan with your mobile device !



APPLICATION EXAMPLES

Plan - A To Transfer Coolant to an Isolated Clean Tank

YTH-CI/GCI transfers cleaned coolant from a coolant tank to an isolated clean tank.

A plate filter is no longer necessary between the tanks, so the users will be free from the maintenance of plate filter.

Furthermore YTH-CI/GCI can separate sludge from the coolant and discharge from contaminant drain port.

Discharged sludge can be collected easily with YTH wire mesh bucket, allowing substantial reduction in coolant maintenance.

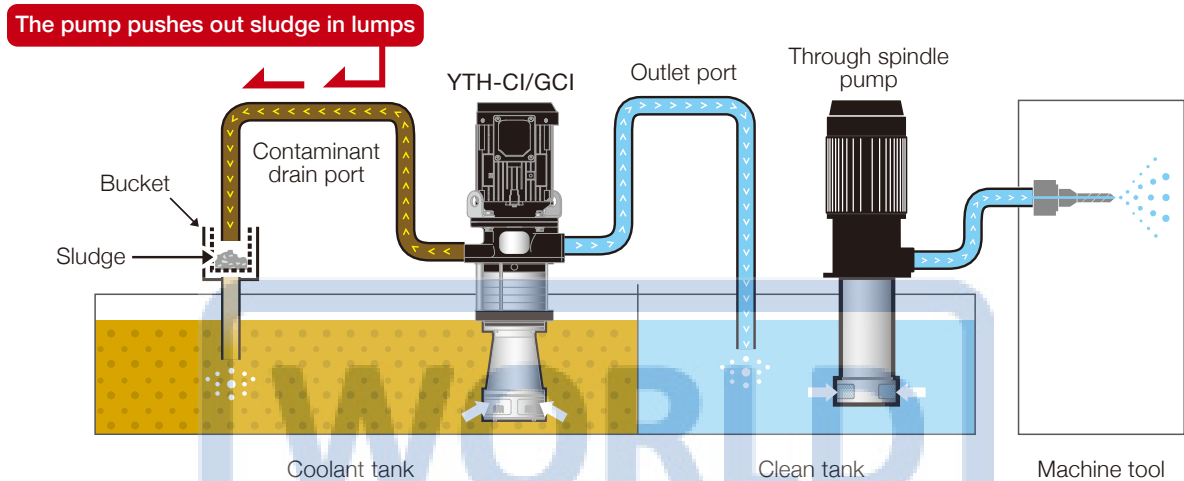

Plan - B Tank Cleaning System ①

YTH-CI/GCI can be an excellent tank cleaner.

The circulation of coolant created by YTH-CI/GCI helps prevent precipitation of sludge in the tank and eliminate sludge effectively, allowing substantial reduction in coolant maintenance.

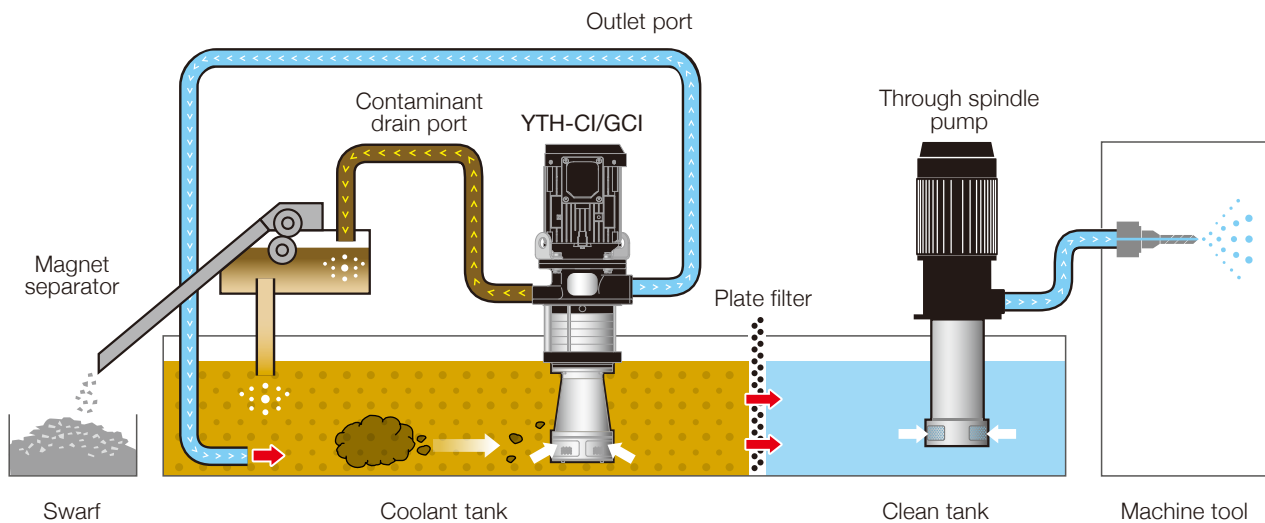

Plan - C Tank Cleaning System ②

YTH-CI/GCI delivers cleaned coolant directly to machine tool. Additionally, once the operation is stopped, it can agitate the coolant tank and effectively collect sludge in the tank by changing the flow direction with switching valve.

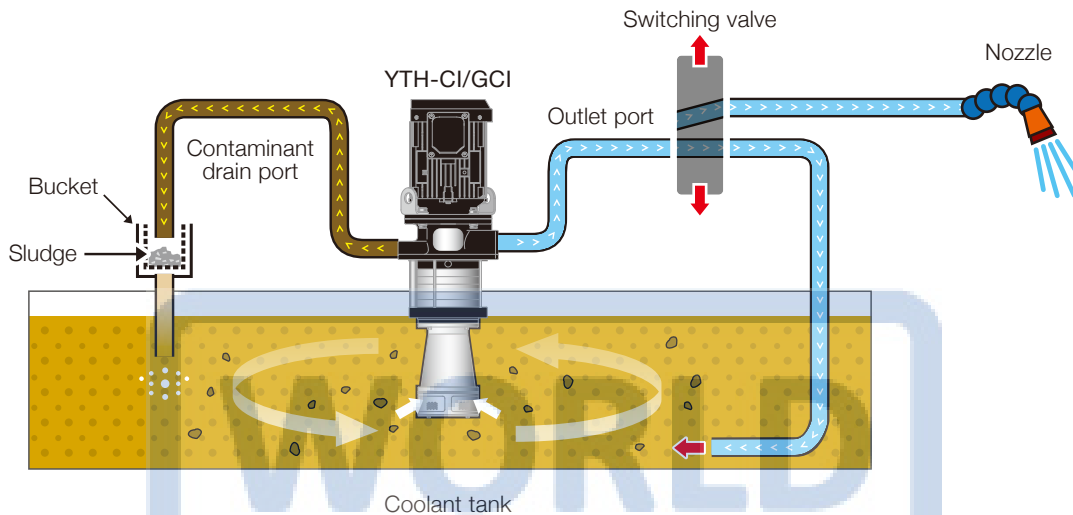

Plan - C

3 roles of YTH-CI/GCI

- 1**

To Supply Cleaned Coolant

Cleaned coolant is supplied at all times, reducing machine downtime.
- 2**

To Collect Sludge

YTH-CI/GCI will effectively collect sludge, ensuring the substantial reduction in tank maintenance.
- 3**

To Agitate the Coolant Tank

Proper agitation of coolant with YTH-CI/GCI can delay the growth of anaerobic bacteria in a coolant.

SAMPLE SYSTEM LAYOUT (YTH-CI)

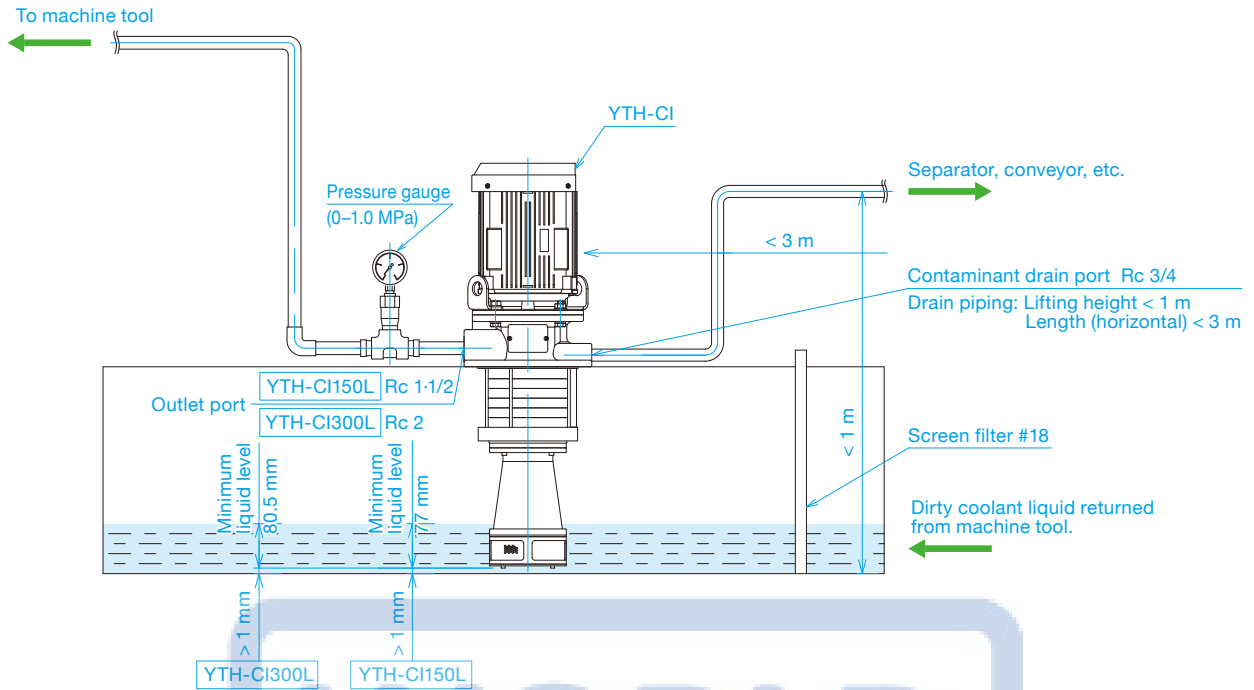

Please be sure to read the instruction manual before use.



Scan with your mobile device !

SAMPLE SYSTEM LAYOUT (YTH-GCI)

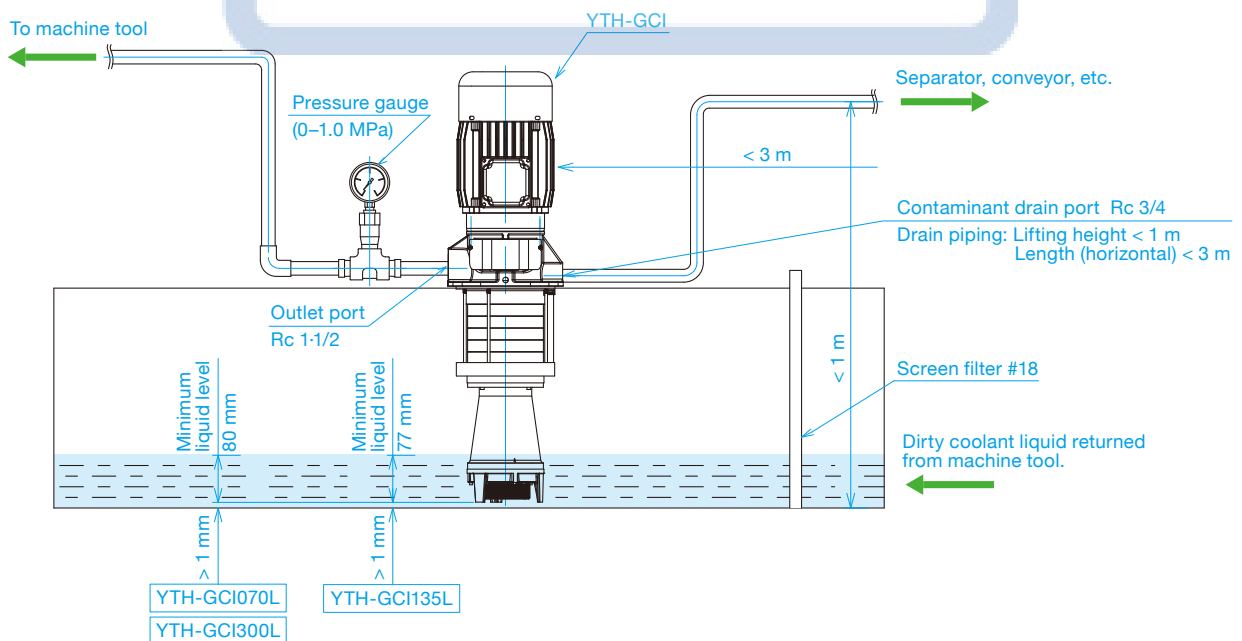

Please be sure to read the instruction manual before use.



Scan with your mobile device !

PERFORMANCE CURVES (YTH-CI)

Water Soluble Coolant [General Performance]

Test oil: JIS K2241 A3 solution containing 2% Water soluble cutting fluid.

■ YTH-CI155C ■ YTH-CI305C
■ YTH-CI152C ■ YTH-CI302C

50 Hz

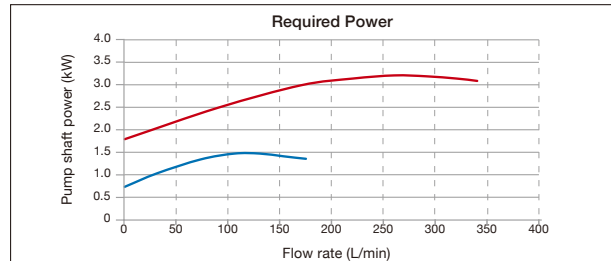
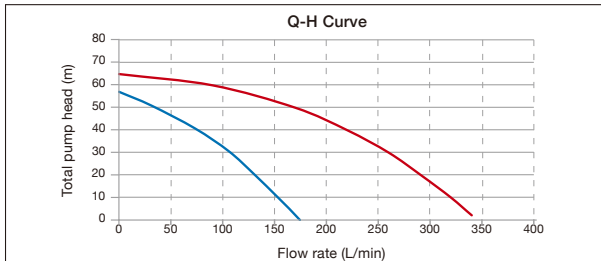

60 Hz

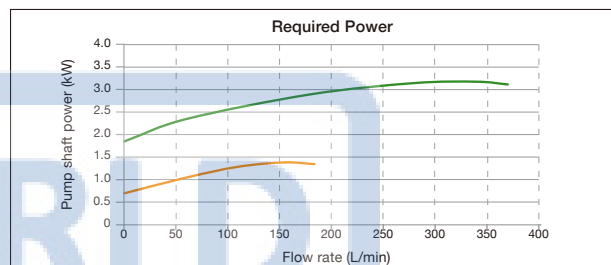
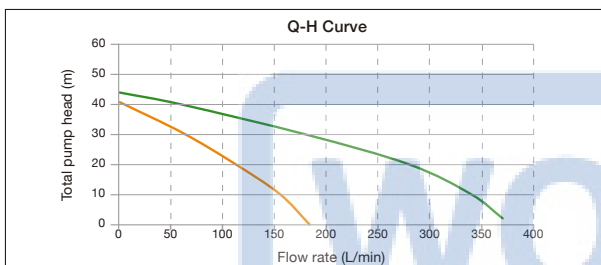

PERFORMANCE CURVES (YTH-GCI)

Water Soluble Coolant [General Performance]

Test oil: JIS K2241 A3 solution containing 2% Water soluble cutting fluid.

50 Hz

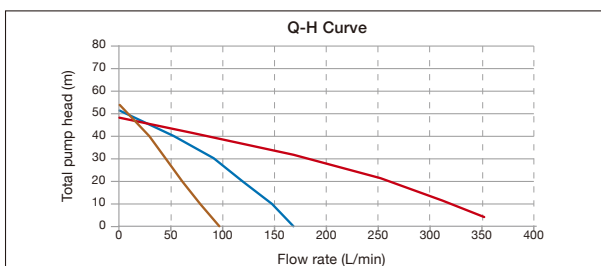

■ YTH-I135CG
■ YTH-I303CG
■ YTH-I075CG

60 Hz

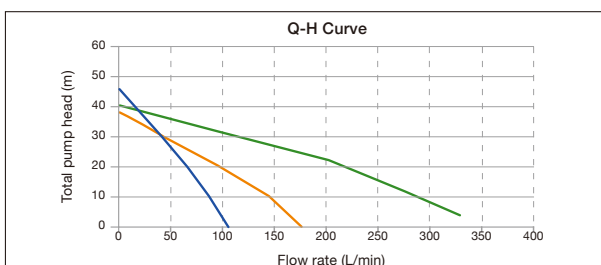

■ YTH-I132CG
■ YTH-I302CG
■ YTH-I073CG

YTH WIRE MESH BUCKET (Sludge Collection Bucket)

YTH wire mesh bucket is made of stainless steel with double layered structure (Lower and upper layers).

The dirty coolant discharged from contaminant drain port will be strained through its wire mesh and only sludge will be collected.

Compatible Sludge Materials for YTH Wire Mesh Bucket (Sludge Collection Bucket)

- Water soluble coolant.
- Magnetic materials (Cast metal), Non-magnetic materials (Aluminum).



[Simple Layout to Collect Sludge]

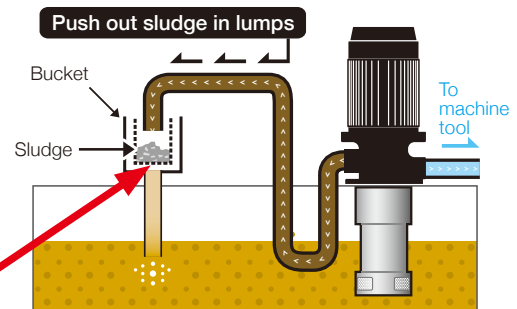

Model	Sludge materials	Wire mesh (Lower layer/Upper layer) μm	Expected flow rate L/min	External dimensions mm
YTH Wire Mesh Bucket 135A (50/100 μm)	Aluminum	50/100	20-40	$\phi 135 \times 220$
YTH Wire Mesh Bucket 250A (50/100 μm)			80	$\phi 250 \times 300$
YTH Wire Mesh Bucket 250B (250/500 μm)	Cast metal/Aluminum	250/500		

*As a guideline, empty the bucket each time the bucket is filled about 40% of its capacity.

YTH Wire Mesh Bucket 135A

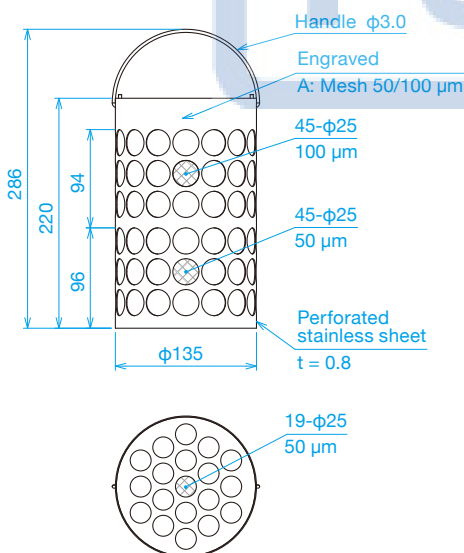

YTH Wire Mesh Bucket 250A/B

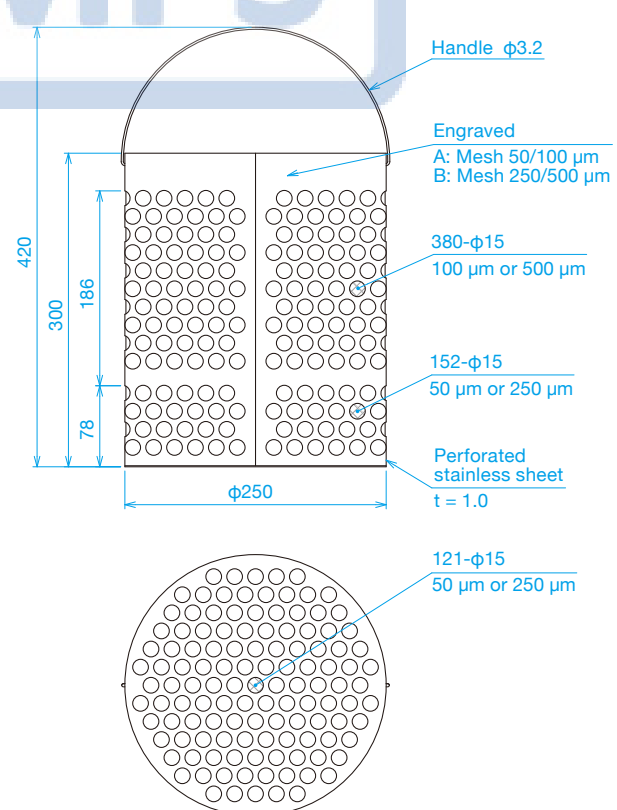



A Fluid Control System That Reduces Annual Electric Power Cost by Up to 61%

Just the use of NOP filter pump by itself cuts the annual electric power cost by about 41%. Additional savings of about 20% would be achieved, or a total of 61%, through the use of the TAZUNA™ fluid control system.

Trimming the production costs is a way to improve your competitiveness. The saving impact will be greater in a plant with a multiple of machining center operating. Reduction in power consumption enables trimming of CO² and is an effective measure against global warming.

Comparison of Annual Electric Power Bills

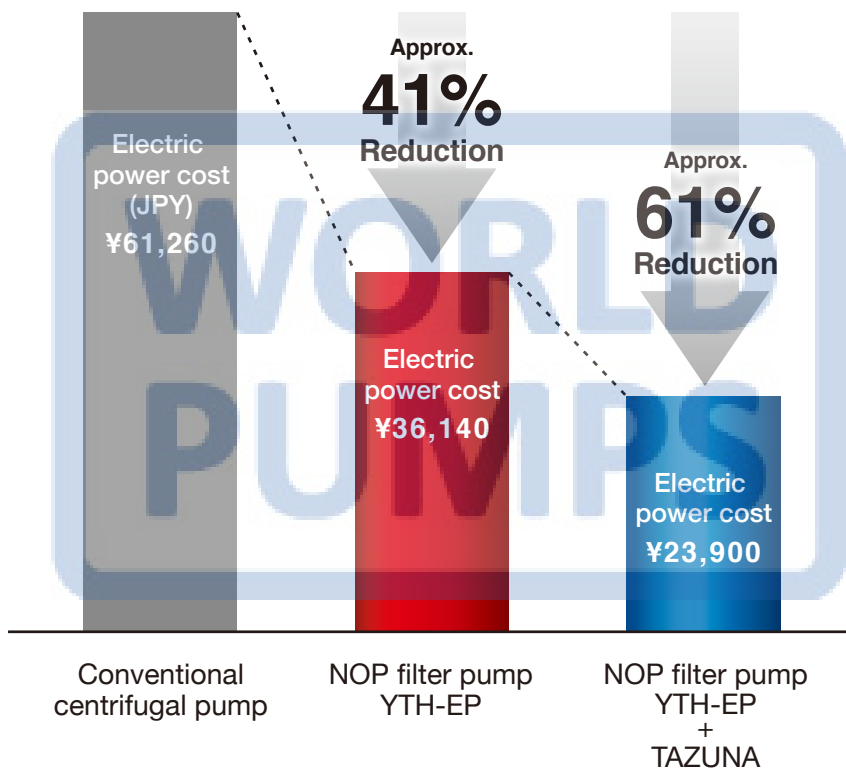

Power Consumption Graph on a Test Operation

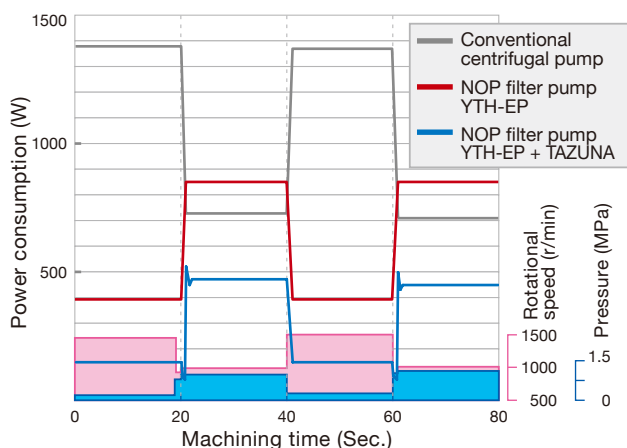

- Operating cycle: total 80 seconds cycle
 Unload (0 MPa) 20 sec.
 → Through-coolant (1.1 MPa) 20 sec.
 → Unload (0 MPa) 20 sec.
 → Through-coolant (1.1 MPa) 20 sec.
- The energy-saving effect will vary due to the difference in machining pressures and drill diameters.
- The calculation is based on operation 8 hours/day, 365 days/year, and the electric power billed at ¥20/kWh.

TAZUNA™ Fluid Control System (Software)

TAZUNA™ is an automatic fluid control system (software) developed by NOP. The system uses a pressure sensor to identify the drill diameter being used by the machining center. It continuously controls the NOP filter pump, adjusting the pressure and flow rate instantaneously according to the drill movement. The absence of unneeded pressure means no extra pressure is wasted through the relief valve. The power consumption is greatly reduced while maintaining machining accuracy.

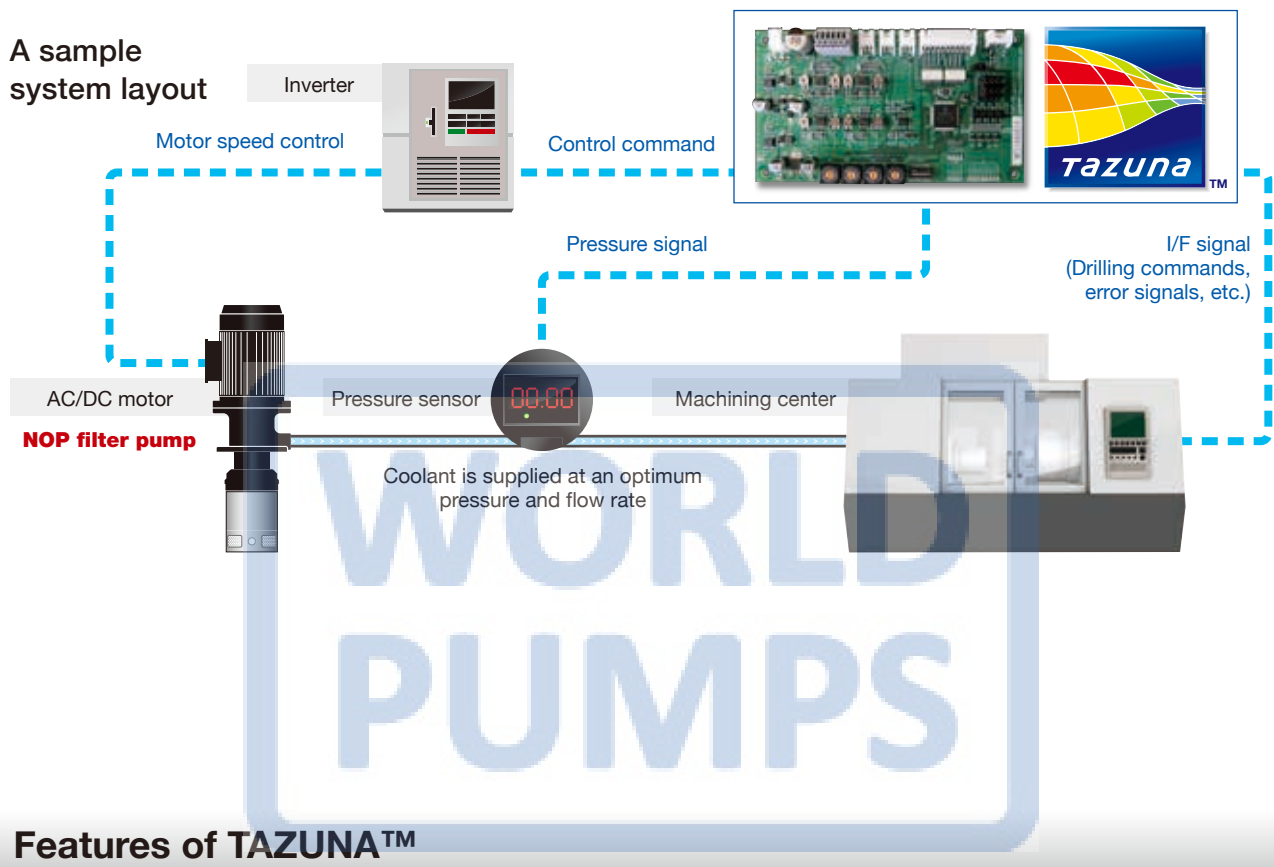

Features of TAZUNA™

- **Additional savings in energy**

TAZUNA™ adjusts the motor within the NOP filter pump to an optimum speed for the drill diameter in use, so that significant energy savings and CO² reduction can be achieved.

- **Improving machining accuracy**

The system is compatible with any drill diameter. Automatic control of the pressure to an optimal value stabilizes the machining accuracy.

- **No initial settings required**

As an automatic drill identification system is pre-installed, the system is ready to use. No initial setting and other cumbersome programming (for different drills) are required on the machining end.

- **Warning function**

Intelligent System alarms user in advance of upcoming performance deterioration of the pump, so that corrective action can be taken and production-loss can be reduced.

- **Constant pressure control**

Regardless of drill hole diameters or numbers, coolant is automatically supplied at constant pressure by fixed pressure setting.

- **Compact and low cost**

The circuit board is a compact and low-cost single card, complete with required interface.

Automatic Drill Identification System

A Flowchart for the Automatic Drill Identification System

- ① In the unload status (While machining is stopped), the system runs at the designated speed in the chip removal mode.
- ② Following a coolant on input, the speed changes to the drill-identification speed, and identifies the drill hole diameter.
- ③ The system controls the rotational speed so as to give an optimum machining pressure and flow rate for the drill-hole diameter as identified. (The system continuously controls the rotational speed to give an optimum machining pressure and flow rate during the machining of work.)
- ④ On completion of the drilling, the system returns to the unload status.

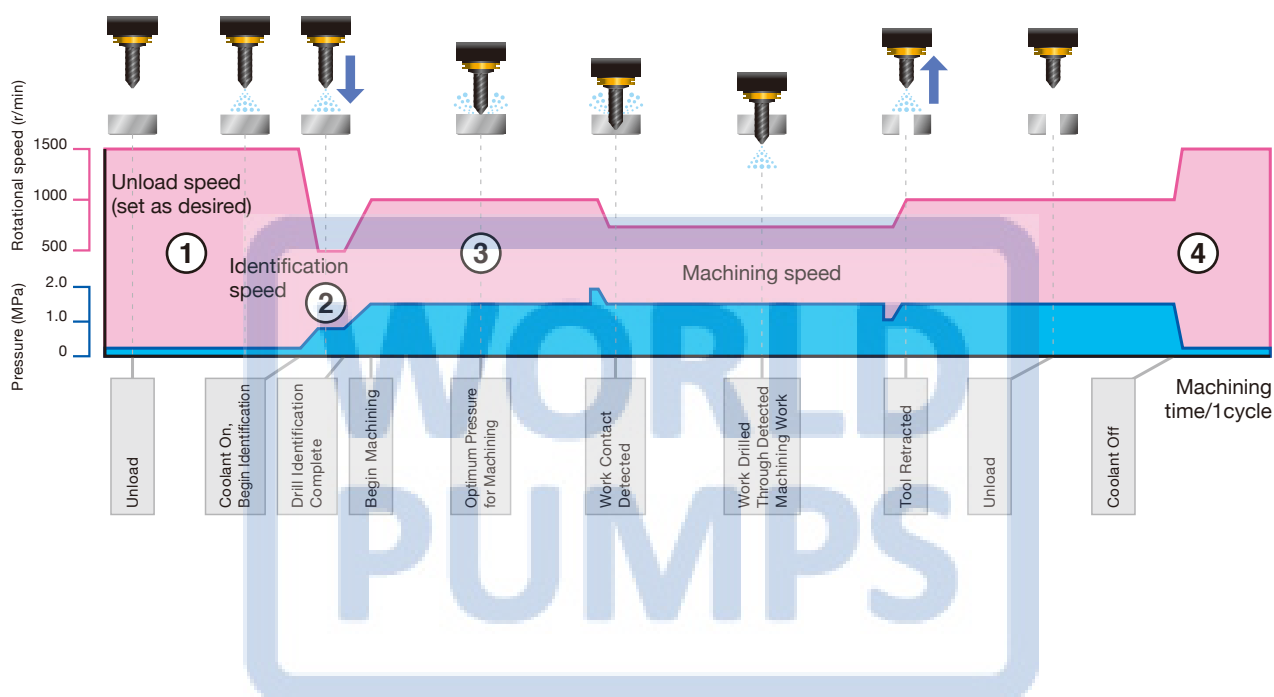

Please be sure to read the instruction manual before use.



← Scan with your mobile device !

NOP FILTER PUMP—Coolant Pump with Built-in Filtration System

YTH-EP



- Turbulence™ Filter
- Plunger Pump/7.0 MPa, 6.0 MPa, 3.5 MPa, 3.0 MPa
- Compatible with the TAZUNA™ Fluid Control System (Software)



YTH-ES



- Turbulence™ Filter
- Trochoid™ Pump/2.0 MPa, 1.5 MPa
- Compatible with the TAZUNA™ Fluid Control System (Software)



YTH-CT/CS



- Double-cyclone Filter
- Trochoid™ Pump/2.0 MPa, 1.5 MPa
- Compatible with the TAZUNA™ Fluid Control System (Software)



Pump Model	YTH-EP (Turbulence™ Filter + Plunger Pump)				YTH-ES (Turbulence™ Filter + Trochoid™ Pump)		YTH-CT/CS (Double-cyclone Filter + Trochoid™ Pump)		
Pump Specifications									
Pump Model	P008	P010	P014	P016	S208	S216	T208	T216	S216
Flow Rate (L/min)	12.0/14.4	15.0/18.0	21.0/25.2	24.0/28.8	12.0/14.4	24.0/28.8	12.0/14.4	24.0/28.8	
Compatible Fluid	Water soluble coolant/Non-water soluble coolant*2						Water soluble coolant		
Maximum Allowable Viscosity (mm ² /s) (Filtration Rating)	15 (20 μm)				15 (20 μm)/32 (50 μm)		22		
Liquid Temperature Range (°C)	-5-60								
Rotational Speed (min ⁻¹)	1500/1800								
Maximum Pressure (MPa)	7.0/7.0	7.0/6.0	7.0/7.0	3.5/3.0 (2.2 kW) 7.0/6.0 (3.7 kW)	1.5/1.5	2.0/2.0	2.0		
Total Pump Head (m)	-								
Filtration Type	Turbulence™ filter						Double-cyclone filter		
Filtration Rating (Nominal)	20 μm/50 μm						Water-soluble coolant fluid 100 μm: 99.9% (Silica sand: Specific weight 2.7)		
Contaminant Drain Port (L/m)	30-40 (Discharge pressure 0.02 MPa)								
Remarks	Install a plate filter of ≥ 18 mesh on the suction end of the tank.								
Painted Color of the Pump	Matte black (Approximately Munsell N1.0)								
Approximate Weight (kg)	20				16				
Relief Valve Specifications									
Valve Type	External return type								
Set Pressure (MPa)	7.0/7.0	7.0/6.0	7.0/7.0	3.5/3.0 (2.2 kW) 7.0/6.0 (3.7 kW)	1.5/1.5	2.0/1.5	2.0/1.5		
Motor Specifications*1									
Model Number	2200A3		3700A3	2200A3/3700A3	750A3	1500A3	750A3	1500A3	
Motor Specifications	3-Phase squirrel-cage induction motor, totally enclosed with external fan, flange-mounting type								
Output (kW)	2.2		3.7	2.2/3.7	0.75	1.5	0.75	1.5	
Voltage (V)	200/200/220/230								
Frequency (Hz)	50/60/60/60								
Rotational Speed (min ⁻¹)	1460/1755/1765/1770		1460/1755 1765/1765	1460/1755 1765/1770 1460/1755 1765/1765	1440/1730 1745/1745	1445/1740 1750/1755	1440/1730 1745/1745	1445/1740 1750/1755	
Rating	S1								
Current (A)	10.6/9.40/9.20/9.20		15.6/14.6 13.8/13.6	10.6/9.40 9.20/9.20 15.6/14.6 13.8/13.6	3.80/3.40 3.40/3.40	6.80/6.40 6.00/6.00	3.80/3.40 3.40/3.40	6.80/6.40 6.00/6.00	
Number of Phases	3								
Number of Poles	4P								
Insulation Class	F								
Approximate Weight (kg)	33	42	33, 42	18	23	18	23		
Protection Rating	IP55								
Approvals	IE3, CE								

*1 Please contact us if you need more information about other motor's specifications. *2 Please contact us if you use non-water soluble coolant.

YTH-CI



- Reverse-cyclone Filter
- Impeller Pump
- Total Pump Head: 40 m–65 m



YTH-GCI



- Reverse-cyclone Filter
- Impeller Pump
- Total Pump Head: 35 m–50 m



Pump Model	YTH-CI (Reverse-cyclone Filter + Impeller Pump)					YTH-GCI*1 (Reverse-cyclone Filter + Impeller Pump)					
Pump Specifications											
Pump Model	I155C	I152C	I305C	I302C	I075CG	I073CG	I135CG	I132CG	I303CG	I302CG	
Flow Rate (L/min)	150 (Max. flow rate)		300 (Max. flow rate)		70		135		300		
Compatible Fluid	Water Soluble Coolant/Non-water Soluble coolant*2										
Maximum Allowable Viscosity (mm ² /s) (Filtration Rating)	22										
Liquid Temperature Range (°C)	-5–60										
Rotational Speed (min ⁻¹)	3000	3600	3000	3600	3000	3600	3000	3600	3000	3600	
Maximum Pressure (MPa)	-										
Total Pump Head (m)	55	40	65	45	50	40	50	35	45	40	
Filtration Type	Reverse-cyclone Filter										
Filtration Rating (Nominal)	Water-soluble coolant fluid 100 μm: 99.9% (Silica sand: Specific weight 2.7) Non water-soluble coolant fluid 100 μm: More than 80.0% (Silica sand: Specific weight 2.7)										
Contaminant Drain Port (L/m)	20–35	25–40	45–60	50–70	20–35	20–40	20–35	25–40	30–60	40–70	
Remarks	Install a plate filter of ≥ 18 mesh on the suction end of the tank.										
Painted Color of the Pump	Matte black (Approximately Munsell N1.0)										
Approximate Weight (kg)	23		34	33	8.3	7.3	15		34	33	
Relief Valve Specifications											
Valve Type	-										
Set Pressure (MPa)	-										
Motor Specifications*1											
Model Number	1500AC		3700AC		1100R3		1500R3		2200R3		
Motor Specifications	3-Phase Squirrel-Cage Induction Motor, Totally Enclosed with External Fan, Flange-Mounting Type										
Output (kW)	1.5		3.7		1.1		1.5		2.2		
Voltage (V)	200/200/220/230					200					
Frequency (Hz)	50/60/60/60					50	60	50	60	50	60
Rotational Speed (min ⁻¹)	2890/3460 3485/3495		2910/3490 3515/3525		2800	3440	2880	3460	2880	3540	
Rating	S1										
Current (A)	6.00/5.80/5.40/5.20		13.6/13.2/12.2/11.8		4.7	6.1	6.5	7.2	10.6	10.0	
Number of Phases	3										
Number of Poles	2P										
Insulation Class	F										
Approximate Weight (kg)	20		36		20		25		36		
Protection Rating	IP55										
Approvals	IE3, CE										

*1 This table only contains the specifications of GCI's typical motor (R3). For the details of other motors, please contact us. *2 Please contact us if you use non-water soluble coolant.

TROUBLESHOOTING GUIDE

Symptom	Possible Causes	Check Methods	Possible Remedies	
No discharge from outlet port.	Motor failure.	Are wires at motor loose or disconnected? Do operation test for motor individually.	Repair or replace motor.	
	Motor is wired incorrectly or disconnected.	Are wires at motor loose or disconnected? Check direction of rotation.	Rewire motor in a correct rotation indicated on label.	
	Coupling is damaged.	Check connected area between pump and motor.	Replace coupling.	
	Insufficient liquid level.	Check liquid level in the tank.	·Add enough liquid. ·Control liquid level with level sensor.	
	Inlet port is clogged.	Check the inlet port for clogging.	·Periodical cleaning around inlet port. ·Insert a plate filter prior to the inlet port as a "pre-filtration device."	
	Turbulence filter is clogged. *Only applies to YTH-EP and ES.	·Does pump deliver liquid from contaminant drain port? ·Is there abnormal noise? ·Is there tramp oil?	·Perform backwashing. (Please be sure to read the instruction manual.) ·Take measures to prevent suction of air or tramp oil.	
	Insufficient flow or pressure.	Impeller is clogged with sludge, pump failure.	Check for impeller clogging and damage.	·Remove sludge. ·Repair or replace pump.
		Air drawn into pump or pipes.	After long storage or right after replacing coolant, pump may not discharge properly due to the air trapped inside the pump.	·Perform air-bleeding on pump or piping. ·If there is a check valve in outlet line, do it right before the one.
	Abnormal noise.	Pump failure or wear.	·Does motor rotate? ·Are viscosity and lubricity adequate? ·Is there abnormal noise?	Repair or replace motor. Change the types of coolant you use.
		Cavitation, Aeration.	Is pump sucking foam or air?	Take measures to prevent suction of air or tramp oil. (ex. Change pump location, use partition or anti-foaming agent.)
Outlet port size is too big.		Is outlet flow sufficient as specified?	Replace with smaller port.	
Relief valve pressure setting.		Does pressure build up when tightening the relief valve's pressure control screw?	Tighten up the relief valve's pressure control screw to the required level.	
Relief valve fixing.		Does pressure not build up when tightening the relief valve's pressure control screw?	·Repair or replace relief valve. ·Remove tramp oil.	
No discharge from contaminant drain port.	Contaminant drain port piping is too long or too high.	Take off a pipe from the contaminant drain port and check if liquid is properly being delivered or not.	Piping must be no higher than 1 m from the tank bottom vertically, and no longer than 3 m horizontally.	
	Clogging of contaminant drain port.	Check the clogged area in the pipeline.	·Clean inside the pipe periodically. ·Minimize the number of bends in piping. ·Replace with larger port.	
	Clogging or failure of suction impeller.	Check the suction impeller for clogging or damage.	·Remove accumulated sludge. ·Repair or replace pump.	
Liquid leaks.	Oil seal is deteriorated or damaged.	Does liquid leak from near the coupling connected area?	Repair or replace pump.	
	Gasket is deteriorated or damaged.	Does liquid leak from connected area?	Repair or replace pump.	
Breaker or thermal trips out.	·Motor failure. ·Wiring errors.	·Check motor wiring. ·Does motor start?	·Rewire motor. ·Repair or replace motor.	
	Overloading.	Are motor output rating and liquid viscosity adequate?	·Use motor with higher output rating. ·Use pump with lower capacity. ·Lower the pressure setting. ·Change the coolant types.	
	·Coolant type is incompatible. (Viscosity is too high or insufficient lubricity.) ·Pump failure.	·Is motor rotating? ·Are liquid viscosity and lubricity adequate? ·Is there abnormal noise?	·Repair or replace pump. ·Change the types of coolant you use.	

WORK MATERIAL COMPATIBILITY TABLES

*The compatibility of work materials varies depending on individual tank conditions, such as maintenance status, shapes of work materials (ex. Wool-like or sharp needle-like), the percentage of Si content, whether material is heat-treated or not.
The information below is for a reference only. Please consult us for further details.

✓=Compatible ×=Incompatible ▲=Conditionally compatible

Material		Number (Typical)	Hardness (HV)	EP	ES	CT	CS	CI/GCI
Metal	Carbon steel	S45C	120-269	✓	✓	✓	✓	✓
	Chromium steel	SCr435	255-321	✓	✓	✓	✓	✓
	Chromium molybdenum steel	SCM445	302-415	✓	✓	✓	✓	✓
	Nickel-chromium steel	SNC815	302-415	×	✓	×	✓	✓
	Carbon tool steel	SK95 (SK4)	203-286	✓	✓	×	✓	✓
	High speed tool steel	SKH56	722	×	✓	×	✓	✓
	Alloy tool steel	SKT6	512-580	×	✓	×	✓	✓
	High carbon chromium bearing steel	SUJ5	222-512	×	✓	×	✓	✓
	Spring steel	SUP10	363-429	×	✓	×	✓	✓
	Aluminum alloy	2000, 7000 series	45-130	✓	✓	✓	✓	✓
	Aluminum alloy for die-casting	ADC14	120	×	✓	×	✓	✓
	Brass	C2801P	80-150	✓	✓	✓	✓	✓
	Chromium copper	SCr435	255-321	✓	✓	✓	✓	✓
	Gray cast iron	FC250	160-285	✓	✓	✓	✓	✓
	Ductile cast iron	FCD800	160-300	✓	✓	✓	✓	✓
	Austenitic stainless steel	SUS304	≤ 200	✓	✓	✓	✓	✓
	Ferritic stainless steel	SUS430	183	✓	✓	✓	✓	✓
	Martensitic stainless steel	SUS440C	≤ 615	×	✓	×	✓	✓
	Titanium alloy steel	TP340	110-320	×	✓	×	✓	✓
	Inconel	Alloy625	400-859	×	✓	×	✓	✓
Tungsten steel		100-350	×	✓	×	✓	✓	
Heat-resistant alloy (For aero-engine)	M152	300	×	✓	×	✓	✓	
Non-Metal	Ceramic		2350	×	×	×	×	▲
	Abrasive grain			×	×	×	×	✓
	Carbon			×	×	×	×	×
	Resin			×	×	×	×	×